

**To investigate the properties
of a parallel resonance
circuit****Resonant Circuit**

An electrical circuit that combines **capacitance** and **inductance** in such a way that a periodic electric oscillation will reach maximum amplitude.

Or: -

An electric with **inductance** and **capacitance** chosen to allow the greatest flow of current at a certain frequency.

$$f_r = \frac{1}{2\pi\sqrt{LC}}$$

In a tuned circuit such as a radio receiver, the frequency selected is a function of the **inductance** (L) and the **capacitance** (C) in series.

Resonator

A **resonator** is a device or part that vibrates with and amplifies waves. It naturally oscillates at some frequencies with greater amplitude than at others.

The noun resonator has three meanings: -

1. A hollow chamber whose dimensions allow the resonant oscillation of electromagnetic or acoustic waves.
2. An electrical circuit that combines **capacitance** and **inductance** in such a way that a periodic electric oscillation will reach maximum amplitude.
3. Any system that resonates.

Each of our major organs has its own resonant frequency depending on its **mass** and the **elastic forces** that act on it. **Pain** or **discomfort** occurs in a particular organ if it is vibrated at its **resonant frequency**.

We find that excessive vibration often occurs in motor trucks. It results in **fatigue** and **discomfort** and may cause **visual disturbances**. The vibratory frequency of motorized vehicles is usually **8Hz** or **less**. As might be expected, aircraft and space vehicles have higher vibratory frequencies.

Simple Parallel (Tank Circuit) Resonance

A condition of **resonance** will be experienced in a tank circuit when the **reactances** of the **capacitor** and **inductor** are equal to each other. Because **inductive reactance** increases with increasing frequency and **capacitive reactance** decreases with increasing frequency, there will only be one frequency where these two **reactances** will be equal.

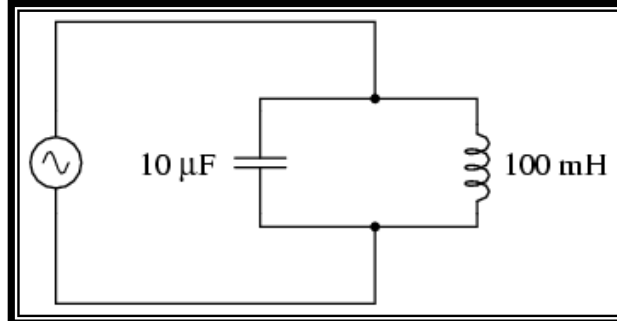

Simple Series Resonance

A similar effect happens in series **inductive/capacitive** circuits. When a state of **resonance** is reached (**capacitive and inductive reactances equal**), the two impedances cancel each other out and the total impedance drops to zero.

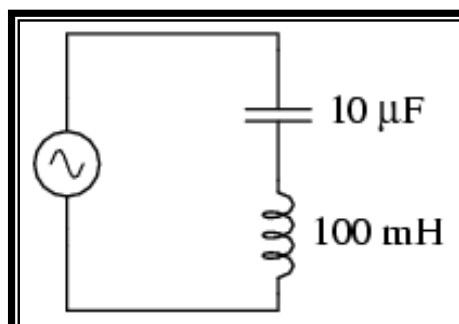

Since we know the equations for determining the **reactance** of each at a given frequency, and we're looking for that point where the two **reactances** are equal to each other, we can set the two **reactance** formulae equal to each other and solve for frequency algebraically: -

$$X_L = 2\pi f L \qquad X_C = \frac{1}{2\pi f C}$$

Setting the two equal to each other represented a condition of equal reactance (**resonance**).

$$2\pi f L = \frac{1}{2\pi f C}$$

Multiplying both sides by f eliminates the f term in the denominator of the fraction.

$$2\pi f^2 L = \frac{1}{2\pi C}$$

Dividing both sides by $2\pi L$ leaves f by itself on the left-hand side of the equation.

$$f^2 = \frac{1}{2\pi 2\pi LC}$$

Taking the square root of both sides of the equation leaves f by itself on the left side.

$$f = \frac{\sqrt{1}}{\sqrt{2\pi 2\pi LC}}$$

Simplifying: -

$$f = \frac{1}{2\pi \sqrt{LC}}$$

The Medical Application of Resonance

Nuclear Magnetic Resonance

Nuclear magnetic resonance (**NMR**) is a non-invasive means of obtaining clinical images and of studying tissue metabolism in vivo. **Bloch** and **Purcell** independently discovered **NMR** in **1946**. Six years later, they were awarded the **Nobel Prize** for their achievements. Since then, the development of **NMR** spectrometers and **NMR** scanners has led to the opening up of whole new branches of **physics, chemistry, biology** and **medicine**.

A new diagnostic technique utilizing magnetic fields shows great promise. It uses an effect called "**Nuclear Magnetic Resonance (NMR)**" and is called "**NMR imaging**". The nuclei of some atoms have small magnetic fields because of their spins, just as electrons do. Usually these spins are randomly oriented, but when placed in a strong magnetic field they align themselves with that field. The directions that these tiny magnets point can be altered by sending in a radio signal.

By measuring the amount of radio waves **absorbed** and **reemitted**, it is possible to measure the **location** and **abundance** of certain elements. It is a type of resonance since only certain frequencies of radio waves will work, depending on the **type** of nucleus and the **strength** of the magnetic field-hence the name **NMR**. One element that can easily be detected using **NMR** is **hydrogen**, which is found in great abundance throughout the body. To make an **NMR** image, one places the patient in a strong magnetic field.

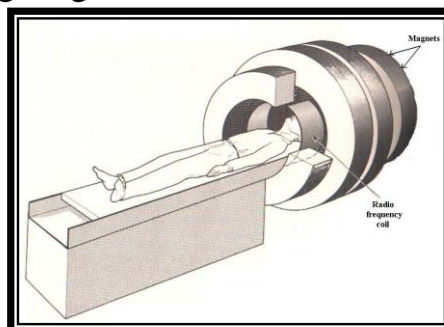

Radio signals are sent into the patient, and their **absorption** and **reemission** are measured and then **analyzed** by a computer. An image is constructed by the computer.

The resolution of the image is not as good as that of some **X-rays**, but **NMR** is still in an early stage of development.

It has two distinct advantages over X-rays: -

- **First**, it has none of the hazards associated with **X-rays**.
- **Second**, **NMR** gives information related to the functioning of organs, whereas **X-rays** are sensitive to their densities, which is not always a good indication of organ function.

NMR imaging promises to be very useful in detecting cancer and other degenerative diseases and seems certain to become an increasingly important diagnostic tool.

