

PHYSIC OF THE SKELETON

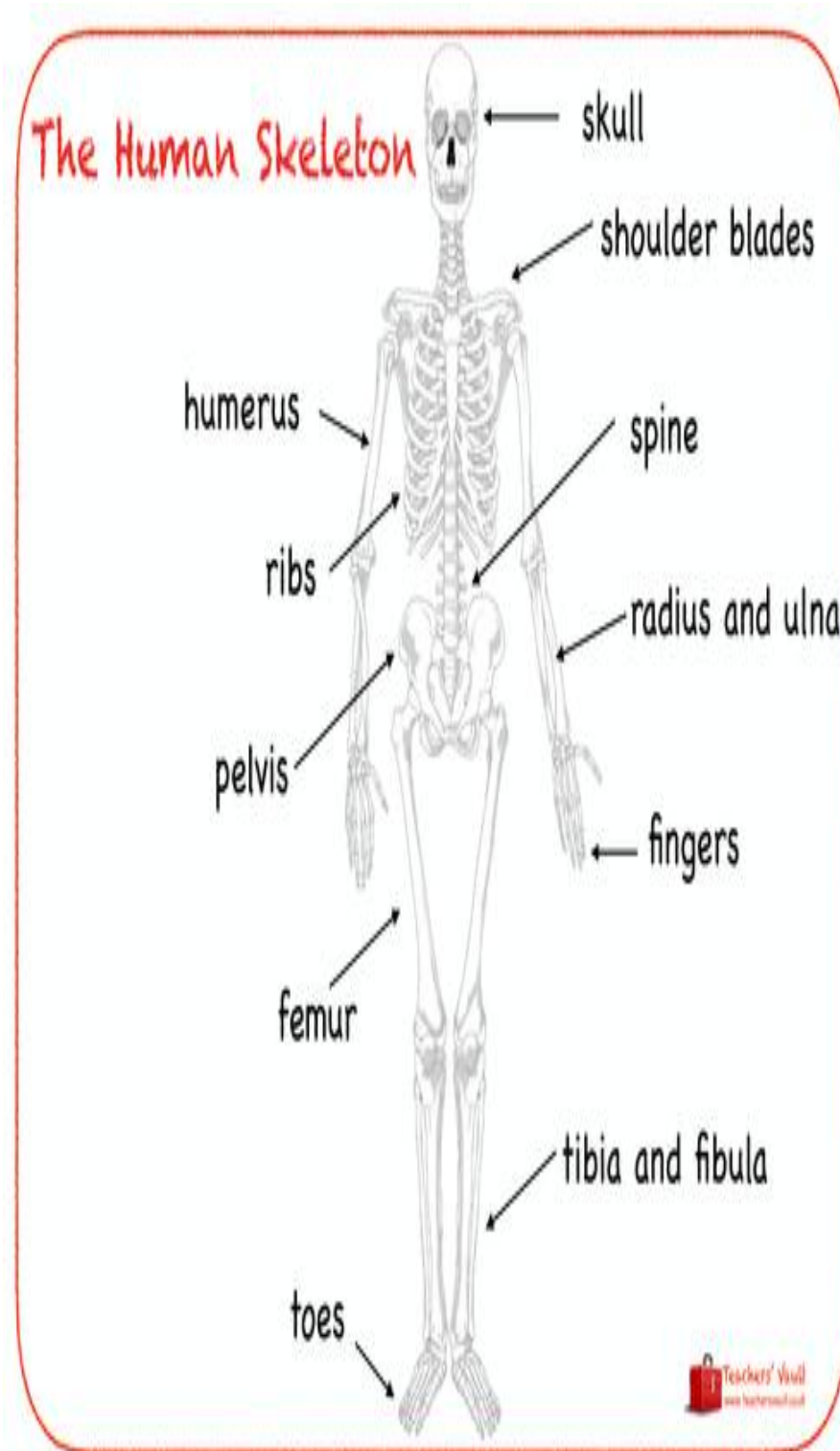

Function of the bones in the body

- 1) **Support** : - It's obvious in the leg, muscles are attached to the bone by tendons and ligament and the system of bones plus muscle supports the body.
- 2) **Locomotion** :- Bone joints permit movement of one bone with respect to another. These hinges or articulation, are very important for walking as well as for many of the other motions of the body.
- 3) **Protection** :-The skull protects the brain and several of the most important sensory organs (eyes, and ears), ribs protect heart and lungs, spinal column protect spinal cord.
- 4) **Storage of chemicals** :-Bones acts as a chemical bank for storing elements for future use by the body. For example, a minimum level of calcium is needed in the blood, if the level falls too low, the calcium sensor causes parathyroid gland to release more Parathormone into the blood; this causes the bone to release the needed calcium
- 5) **Nourishment** :-Teeth are specialized bones that can cut food by incisors, tear it by canines and grind it by molars and thus serve in providing nourishment for the body.
- 6) **Sound transmission**:- The smallest bones of the body are Ossicles in the middle ear ,the Ossicles acts as levers ,its provide an impedance matching system for converting sound vibrations in air to sound vibrations in fluids in the Cochlea, the Ossicles are the only bones that attain full size before birth.

Bone

It is the living tissue and has a blood supply as well as nerves. Most of bones tissue is inert, but distributed through it are the Osteocytes, cells that maintain the bone in a healthy condition. Cells make up about 2% of the volume of bone. If these cells die (due to a poor blood supply), the bone dies and loses of its strength.

Bone remodeling

A continuous process of destroying old bone and building new bone, this process performed by specialized bone cells during human life period , These cells are called :

1. Osteoblast : which build up bone using calcium .
2. Osteoclast : which destroy the bone.

Compared with many body process, bone remodeling is slow work .we have the equivalent of a new skeleton every 7 years. Each day, the Osteoclast destroys bone containing about 0.5 gm of calcium (the bone have about 1000gm calcium), and the Osteoblast builds a new bone using about the same amount of calcium.

Bone remodeling depends on:

1-**Age**

2-**Gender**

While the body is young and growing the activity of the Osteoblast do more than the Osteoclast, but after the body is 35-40 years the activity of Osteoclast is greater than that of the Osteoblasts, resulting in a gradual decrease in bone mass that continuous until death, this is called “Osteoporosis” (porous bones) which is faster in women that in men.

What is bone made of?

By using X-ray, the bones show so well, because large percentage of Ca^{+2} in bone (22%). Ca^{+2} has high atomic number ($Z= 40$). So that it absorbs X-ray much better than soft tissue.

Bone consists of two different materials plus water: -

A- **Collagen**, the major organic fraction, which is about 40% of the weight of the solid bone 60% of its volume.

B- **Bone mineral**, the so-called “inorganic” component of bone, which is about 60% of the weight of the bone and 40 % of its volume.

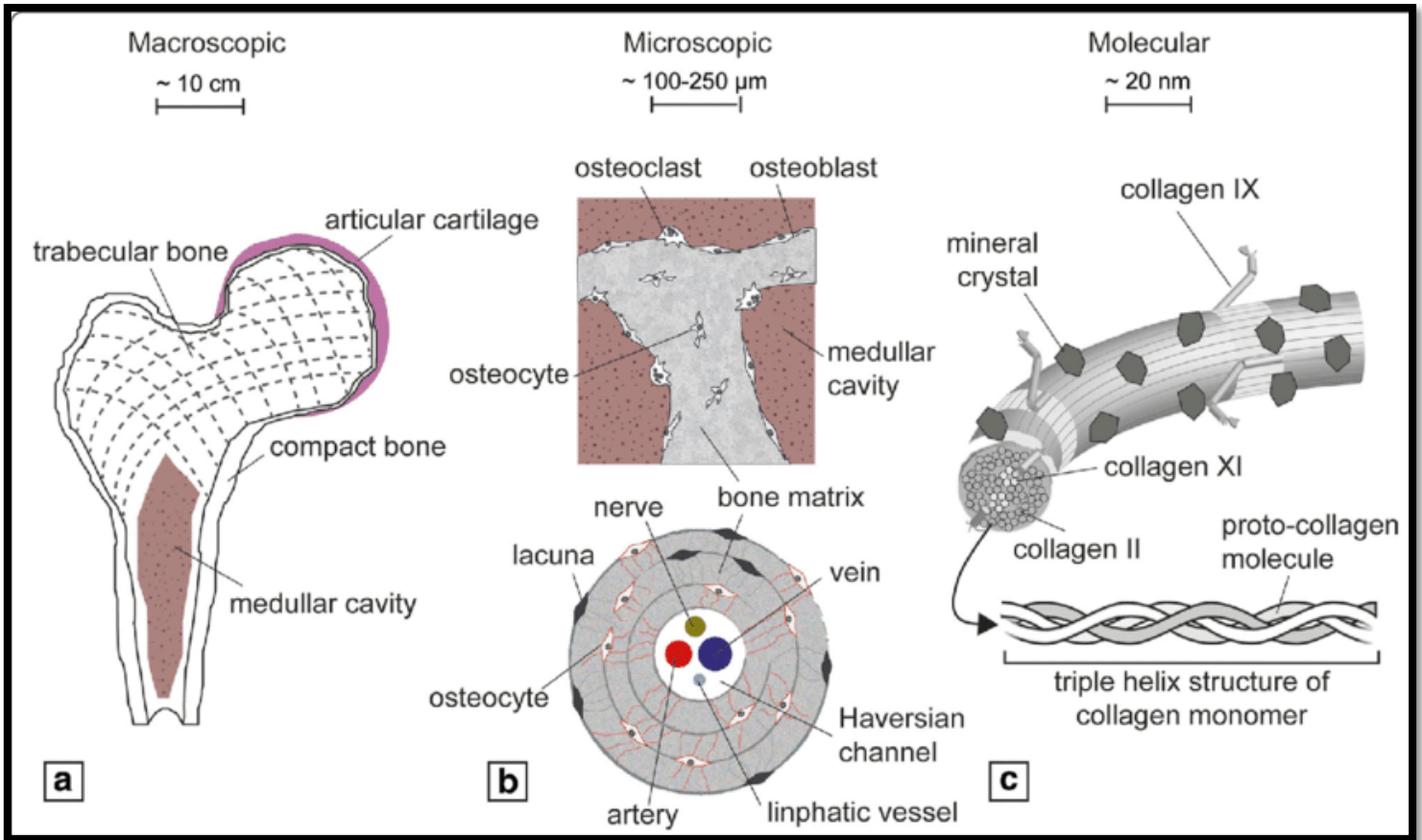

Either of these components may be removed from the bone, and in each case the remainder, composed of only collagen or bone mineral, will look like the original bone, the collagen remainder is quite flexible (like piece of rubber), and can even be bent into a loop. When the collagen is removed from the bone, the bone mineral remainder is very fragile and can be crushed with the finger.

Collagen is apparently produced by the osteoblastic cells; mineral is then formed on the collagen to produce bone. Bone collagen is not the same as the collagen found in many other parts of the body such as the skin. Its structure corresponds to the crucial dimensions of the crystals of bone mineral, and it forms a template onto which the bone mineral crystals fit snugly.

Bone mineral is made up of **calcium hydroxyapatite** $-Ca_{10}(PO_4)_6(OH)_2$. Its similar to the crystals exist in nature ; fluorapatite ,differs from calcium hydroxyapatite in that fluorine takes the place of the (OH). The Bone mineral crystals are rod shape with diameters of 20-70A° and lengths of from 50-100 A° (1 A°=10⁻¹⁰m). **Bone mineral has a very large surface area (4×10⁵ m²)**, the large area permits the bones to interact rapidly with the chemical in the blood and other body fluids.

Composition of compact bone

H= 3.4%	Mg=0.2%
C=15.5%	P=10.2%
N=4.0%	S=0.3%
O=44.0%	Ca=22.2 %
Miscellaneous = 0.2%	

How strong are your bones?

There are 206 bones in the body, can be categorized according to their shape into:

1. A Small pile of flat, plate -like bones such as the shoulder blade (scapula) and some bones of the skull.
2. Second pile of Long hollow bones such as those found in the arms ,legs and fingers
3. Third pile of more or less cylindrical bone from the spine (vertebrae)
4. Fourth pile of irregular bones such as wrist and ankle.
5. Fifth pile of bones such as the ribs.

**Humerus
(long bone)**

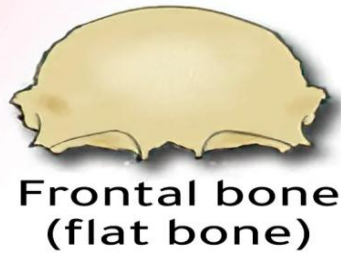

**Frontal bone
(flat bone)**

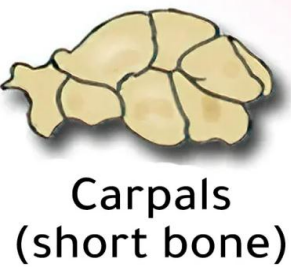

**Carpals
(short bone)**

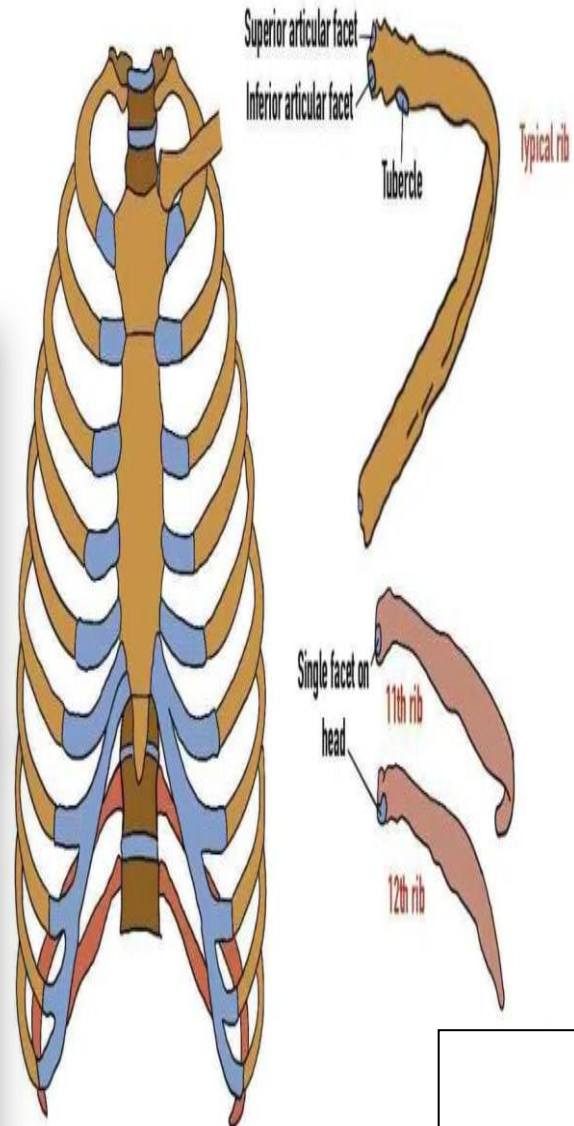

If we cut the bones apart, we can find it's composed of one or a combination of different types of bones:-

1. Solid or compact bone
2. Spongy or cancellous bone made up of thin thread like trabecular bone

Examples in long bones, the long shaft (central shaft) , is a compact bone , while the ends are spongy (trabecular bone).(trabecular bone is considerably weaker than compact bone due to the reduced amount of bone in a given volume).

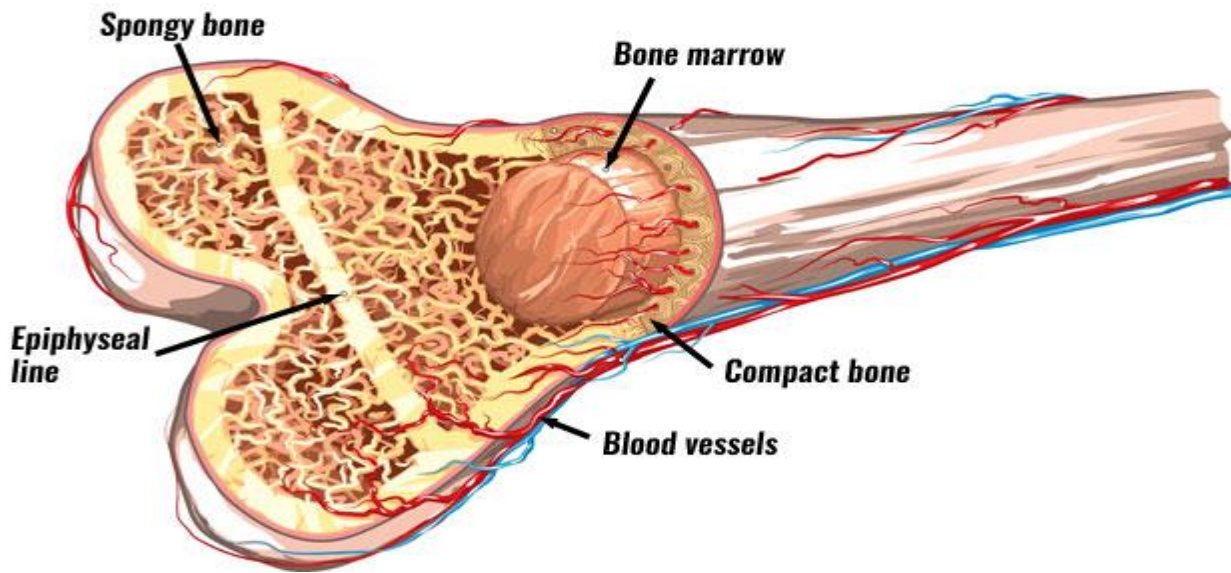

<i>Solid or compact bone</i>	<i>Trabecular bone</i>
compact	Spongy
found in the central shaft	Found in the ends of the long bones
Stronger	Weaker due to reduced amount of bone in the given volume

Note: Bone tissue is the same in the Trabecular and compact bone

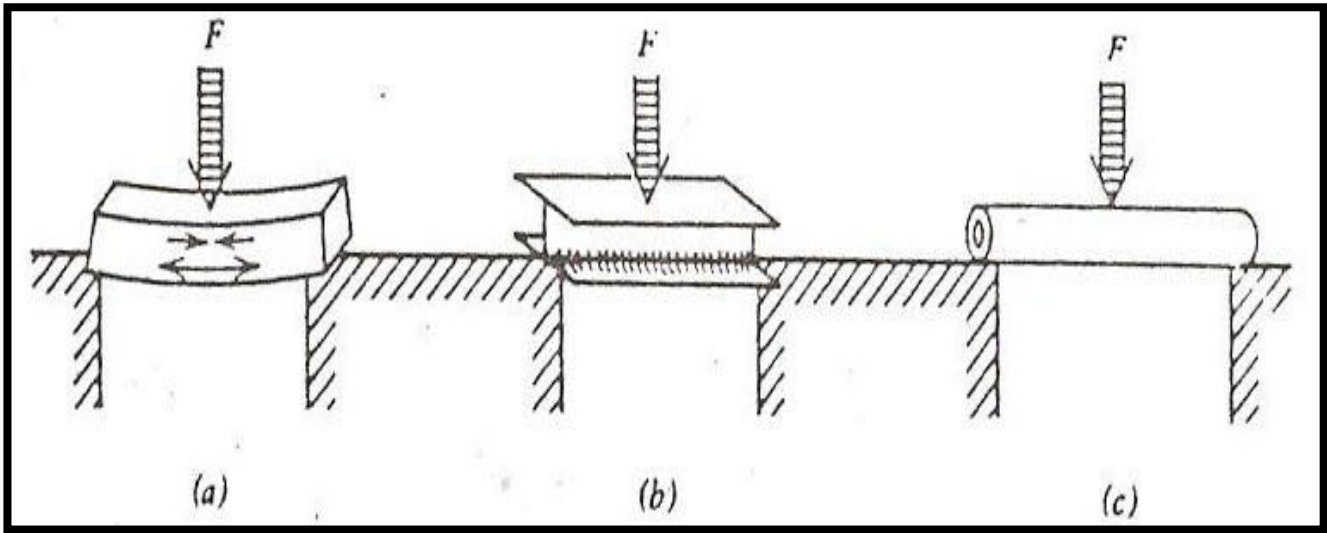

Figure 1. Various types of beams subjected to a force F

A study of the construction of the femur illustrates how well it is designed for its job. Stress (force per unit area) in a bone can be analyzed the same way as a stress in a beam in a building, above figure shows

- a. **Horizontal beam** supported at the ends with a downward force in the Middle. The stresses inside the beam (shown by arrows) are pulling it apart at the bottom (tension) and pushing it together at the top (compression). There is relatively little stress in the center of the beam.
- b. **I beam**, which has a thick Top and bottom joined with a thin web, as a support beam in a building. Stress in the middle is small for this reason it is common to use an I beam.
- c. **Hollow cylinder** (bone shape), when the force may come from any direction, a hollow Cylinder is used to get the maximum strength with a minimum amount of material; it is almost as strong as a solid cylinder of the same diameter. Since the forces on the femur may come from any direction, the hollow cylinder structure of the bone is well suited for support.

The compact bone of the shaft of the Femur is thickest in the center and thinnest at the ends; note again the high quality of the design (with stand the forces on femur from any direction).

The trabecular patterns at the ends of the femur are also optimized for the forces to which the bone is subjected.

What are the advantages of Trabecular bone over compact bone?

1. Where a bone is subject primarily to compressive forces (such as the ends of the bones and in the spine) Trabecular bone gives the necessary strength with less material than compact bone.
2. The Trabecular are relatively flexible, they can be absorb more energy when a large forces are involved such as in walking, running and jumping.

On the other hands Trabecular bone cannot withstand well the bending stress that occurs mostly in the central portions of the long bone.

Mechanical properties of bone

Bone is composed of small hard bone mineral crystals attached to a soft flexible collagen matrix. These components have vastly different mechanical properties that also differ from those of bone. The combination provides a material is as strong as granite in compression and 25 times stronger than granite under tension.

Mechanical properties of bone are:

1) Density

The density of compact bone is surprisingly constant through life at about 1.9 g/cm³ (or 1.9 times as dense as water). In old age the bone become more porous and disappears from the inside or *endosteal*, surface. The density of the remaining compact bone is still about 1.9 g/cm³; it is reduced in strength because it is thinner, not because it is less dense.

2) Length. All materials change in length when placed under tension or compression when a sample of fresh bone is placed in a special instrument for measuring the elongation under tension, as show in figure2 , the strain ($\Delta L / L$) increases linearly at first, indicating that it is proportional to the stress (F/A)__hooke's law .As the force increases the length increases more rapidly ,and the bone breaks at a stress of about 120 N/mm².The ratio of stress to strain in the initial linear portion is young's modulus Y. that is.

$$Y = \frac{LF}{A\Delta L}$$

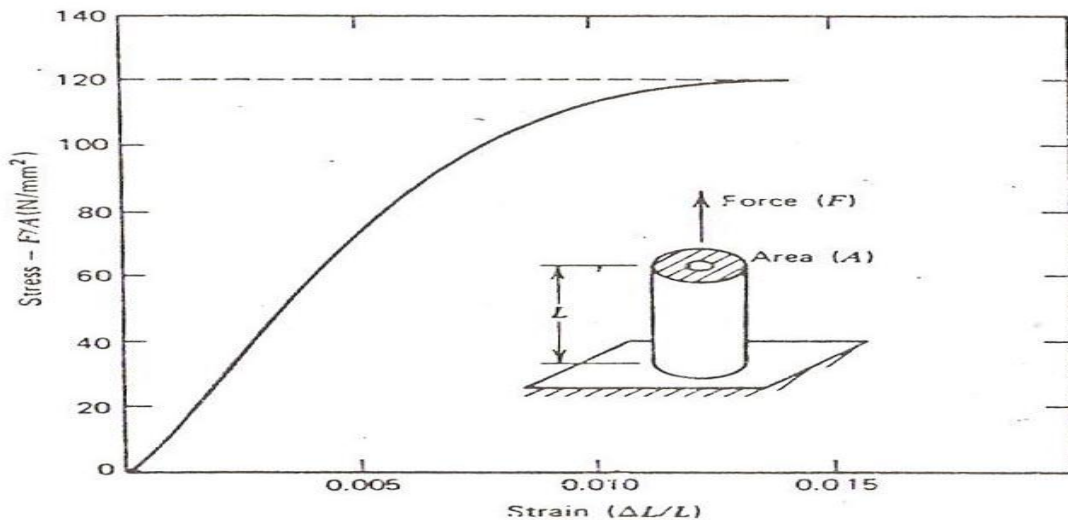

Figure 2. A piece of bone is placed under increasing tension

$$\text{Stress} = (F/A).$$

$$\text{Strain} = (\Delta L / L).$$

$$Y = \frac{\text{stress}}{\text{strain}}$$

$$Y = \frac{(F/A)}{(\Delta L / L)}$$

$$\Delta L = \frac{LF}{AY}$$

Example:-

Assume a leg has a 1.2 m shaft of bone with an average cross-sectional area of 3 cm^2 ($3 \times 10^{-4} \text{ m}^2$) what is the amount of shortening when all of the body weight of 700 N is supported on this leg?

$$\begin{aligned} \Delta L &= \frac{LF}{AY} = (1.2\text{m}) (7 \times 10^2 \text{N}) / (3 \times 10^{-4} \text{m}^2) (1.8 \times 10^{10} \text{N/m}^2) \\ &= 1.5 \times 10^{-4} \text{m} = 0.15 \text{mm} \end{aligned}$$

What is the built-in safety factor in the bones that support the body's weight?

Healthy compact bone is able to withstand a compressive stress of about 170 N/mm^2 before it fractures. The midshaft of the femur has a cross-sectional area of about 3.3 cm^2 (0.5 in^2); it would support a force of about $5.7 \times 10^4 \text{ N}$. The cross sectional area of the shin bone (tibia) is not as great, but the safety margin is satisfactory for most activities except downhill skiing.

The bones do not normally break due to compression; they usually break due to shear or under tension. A common cause of shear is catching the foot and then twisting the leg while falling. A shear fracture often results in a spiral break.

The bones are not as strong under tension as they are in compression; a tension stress of about 120 N/mm^2 will cause a bone to break. Let us consider the forces exerted on a bone during a fall. From Newton's second law, the force exerted during a collision or a fall is equal to the rate of change of momentum, which is simply the momentum of the body divided by the duration of impact. Therefore, the shorter the duration of impact, the greater the force. To reduce the force and thereby reduce the likelihood of fracture, it is necessary to increase the impact time.

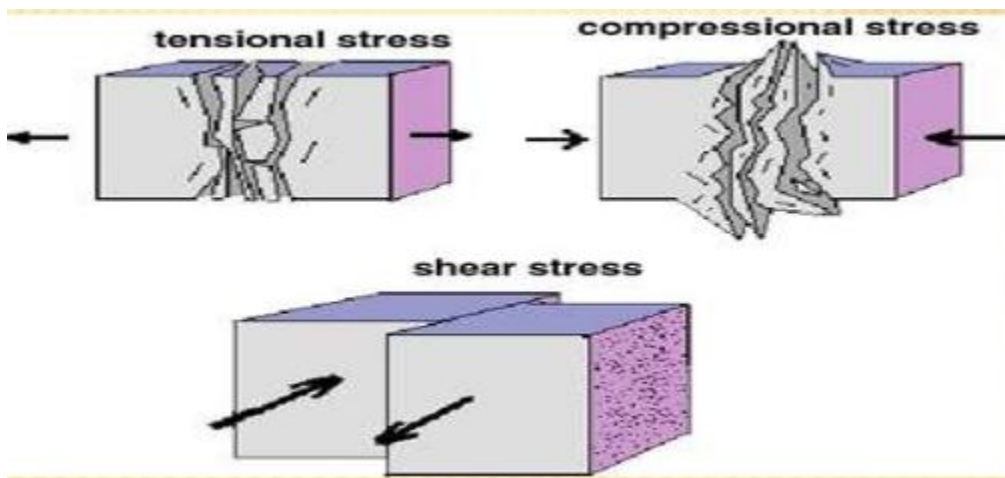

In both falling down and jumping from an elevation, the impact time can be increased significantly by simply rolling with the fall or jump, thereby spreading the change in momentum of the body over a longer time.

Measurements of bone mineral in the body

The strength of bones depends on the mass of bone mineral present. Bone mineral mass decreases slowly 1-2% per year, so physical techniques needed to show changes.

- 1) ***X-ray image***: - The ideal of using an X-ray image to measure the amount of bone mineral is an old one. the major problems of using an ordinary X-ray are:
 - a- The usual X-ray beam has different energies and the absorption of the X-ray by Ca^{+2} varies rapidly with energy in this range of energies.
 - b- Large beam contains much scattered radiation when it reaches the film
 - c- The film is poor detector for making quantitative measurements.

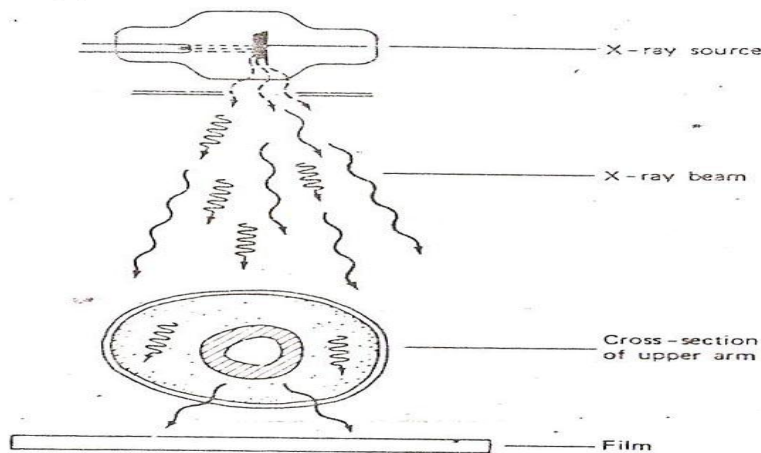

Figure3. conventional X-ray imaging

2) *Photon absorptiometry*

The problems with the X-ray technique were largely eliminated by using

- Monoenergetic X-ray or gamma rays source.
- A narrow beam to minimize scatter.
- Scintillation detector that detects all photons and permits them to be sorted and counted individually.

Bone is immersed in a soft media (like water) to determine of bone mineral mass.

Bone mineral mass (BM gm/cm^2) = $K \log I_0/I$.

Where K is a constant,

I (intensity of X-ray that transmit the bone).

I_0 (intensity before the beam enter the bone),

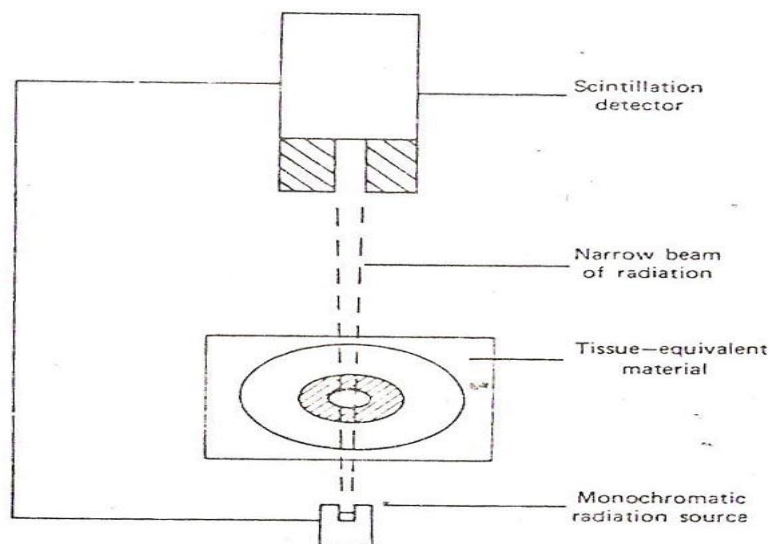

Figure 4. The basic components used in photon absorptiometry

3) *In vivo activation*: whole body is irradiated with energetic neutrons that convert a small amount of the Ca^{+2} and some other elements into radioactive form that give off energetic gamma rays then detected and counted. This detected to give the amount of Ca^{+2} .

Disadvantages of this technique

- 1- Expensive technique.
- 2-Hazard of large radiation exposure.