

Milling

Is the mechanical process of reducing the particle size of solids.

Various terms (crushing –disintegration--dispersion – grinding---& pulverization)

Milling equipment is classified as coarse, intermediate, or fine according to the size of the milled product.

Size is expressed in terms of mesh (no. of openings per linear inch of a screen).

Pharmaceutical application

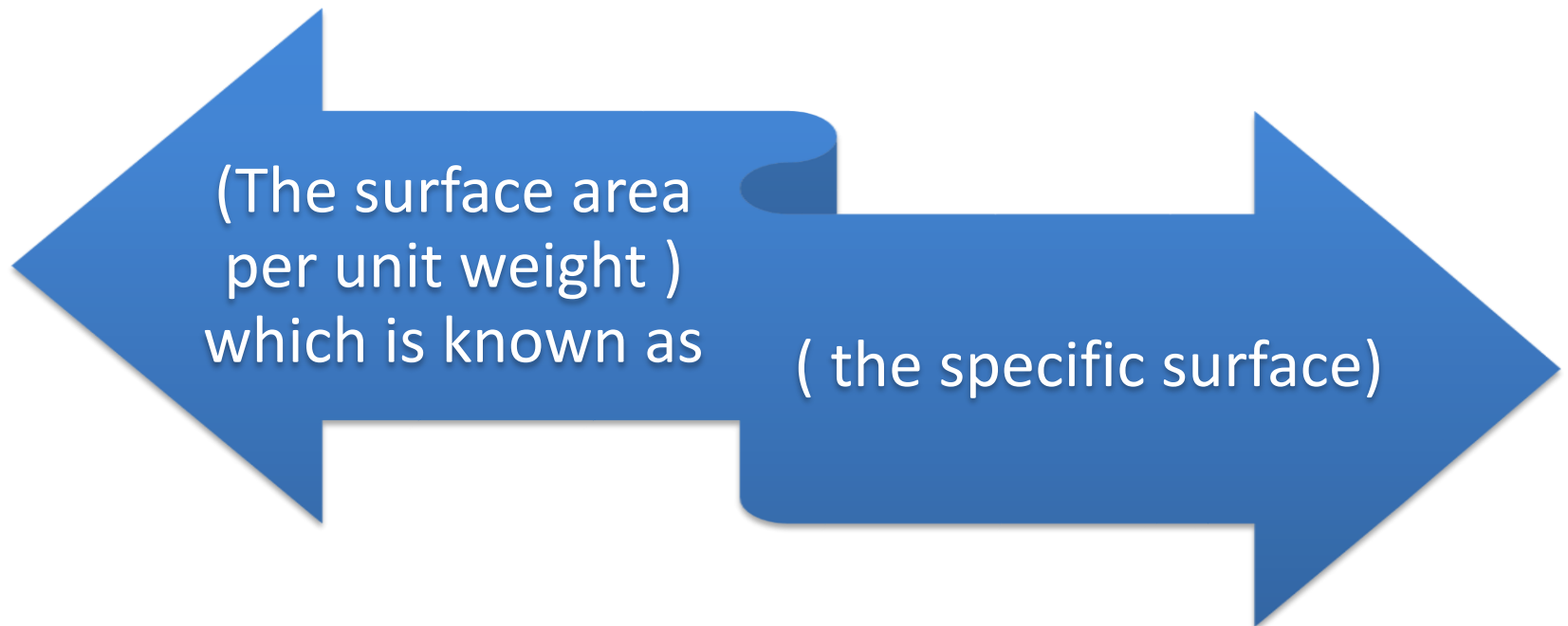

benefits of milling

1-This increased specific surface affects the therapeutic efficiency of medicinal compounds that possess a low solubility in body fluids by increasing the area of contact between the solid & the dissolving fluid.

2-The drying of wet masses may be facilitated by milling, which increases the surface area & reduces the distance the moisture must travel within the particle to reach the outer surface.

3- The mixing or blending of several solid ingredients of a pharmaceutical is easier & more uniform if the ingredients are approximately the same size. This provides a greater uniformity of dose. Solid pharmaceuticals that are artificially colored are often milled to distribute the coloring agent to ensure that the mixture is not mottled & is uniform from batch to batch.

Size distribution & measurement

- Naturally occurring particulate solids & milled solids, the shape of particles is irregular & the size of the particles varies within the range of the largest & smallest particles.
- There is no known method of defining an irregular particle in geometric terms ; however statistical methods have been developed to express the size of an irregular particle in terms of diameter.

For an irregular particle an equivalent particle with the same surface or volume may be substituted. For convenience of mathematical treatment, an irregular particle is considered in terms of an equivalent sphere. So the irregular particle expressed as diameter.

The main methods are used to measure particle size are

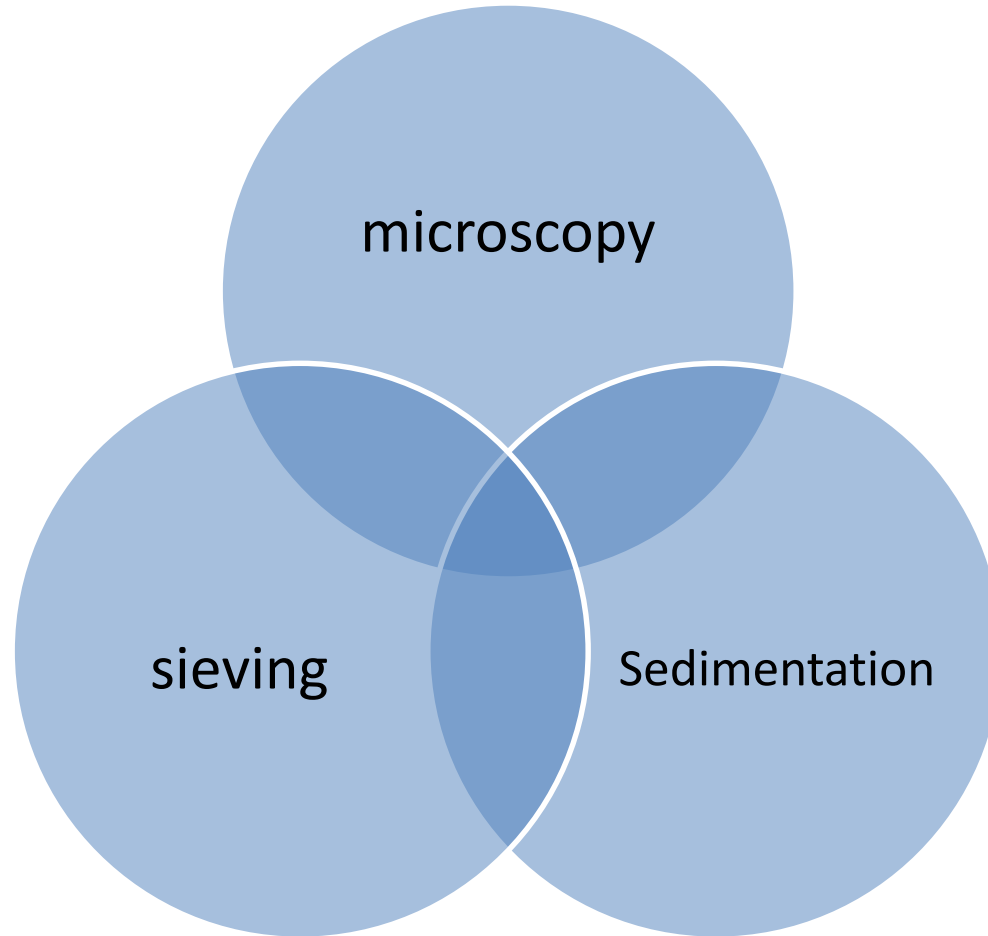

microscopy

- Is the most direct method for size distribution measurement. Its lower limit of application is determined by the resolving power of the lens.

https://www.google.com/search?q=microscope&hl=en&tbm=isch&source=hp&biw=1242&bih=597&ei=c_2MYJveGqGLlwTxrrfIDA&oq=microscope&gs_lcp=CgNpbWcQAzICCAAyAggAMgIIADICCAAyAggAMgIIADICCAAyAggAMgIIADICCA6CAgAELEDEIMBOgUIABCxA1DXSFjCX2DvaWgAcAB4AIABlwGIAboLkgEEMC4xMJgBAKABAaoBC2d3cy13aXotaW1nsAEA&sclient=img&ved=0ahUKewjb4-qy9afwAhWhxYUKHXHXDckQ4dUDCAc&uact=5#imgrc=VGaeH-tQJXsFUM

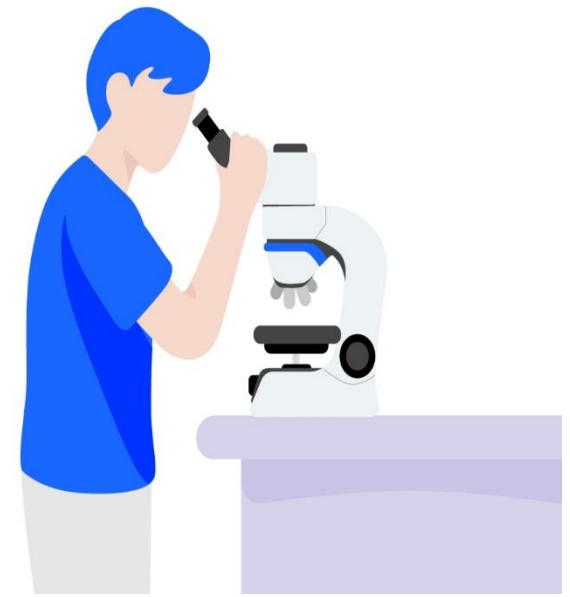

White
light

- an ordinary microscope is used to measure particles from 0.4 to 150 microns.

ultraviolet

- The lower limit may be extended to 0.1 micron

ultramicroscope

- The resolution is improved by use of a darkfield illumination & the size range is from 0.01 to 0.2 micron

The diameters of the particles on the slide are measured by means of a calibrated filar micrometer eyepiece.

the hairline of the eye piece is moved by the micrometer to one edge of a particle & the reading on the micrometer is recorded.

The hairline is then moved to the opposite edge of the particle being measured & the micrometer is read.

The difference between the 2 readings is the diameter of the particle.

All of the particles are measured along an arbitrary fixed line.

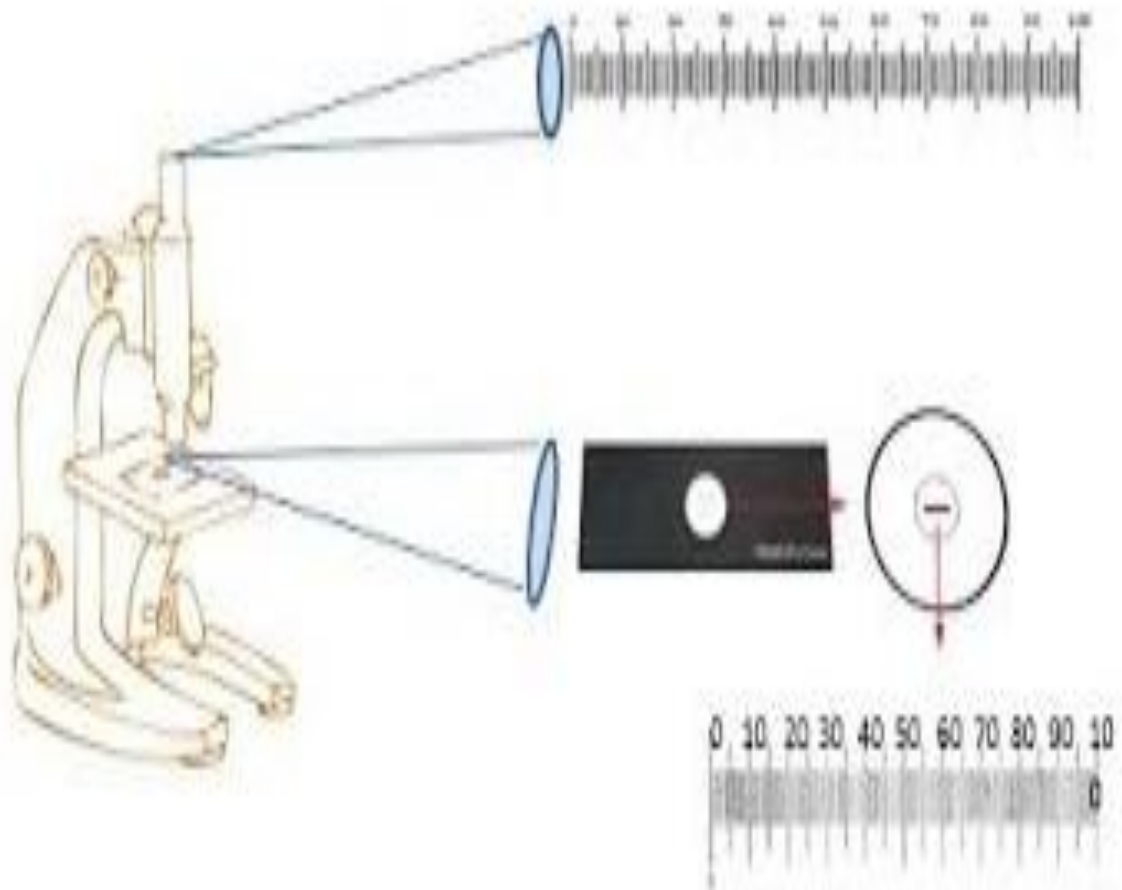

https://www.google.com/search?q=microscope+to+measure+particle+size&tbm=isch&ved=2ahUKEwj5g-a59afwAhXO0oUKHQsVDrlQ2-cCgQIABAA&oeq=microscope+to+measure+particle+size&gs_lcp=CgNpbWcQAzoECAAQQzoCCAA6BggAEAgQHjoECAAQGfDA_hFY0LoSYPu8EmgAcAB4AIAB2AOIAeEdkgEKMC4yMS4yLjEuMZgBAKABAaoBC2d3cy13aXotaW1nwAEB&sclient=img&ei=gv2MYPm6As6llwSLqriQCw&bih=597&biw=1242&hl=en#imgrc=HuMoA2HMszzlEM

Eyepieces with grids of circles & squares are used to compare the cross sectional area of each particle in the microscopic field with one of the numbered patterns. The number of particles that best fits one of the numbered particles is recorded. The process repeated until the size range is covered.

Total number of fields depends on the number of particles per field. Acc to British std at least 625 particles and this depends on the particle size distribution. If it is wide so need to read more. If it is narrow so 200 particles are enough.

There is a considerable variation among operators using the microscopy technique.



Sieving is the most widely used because

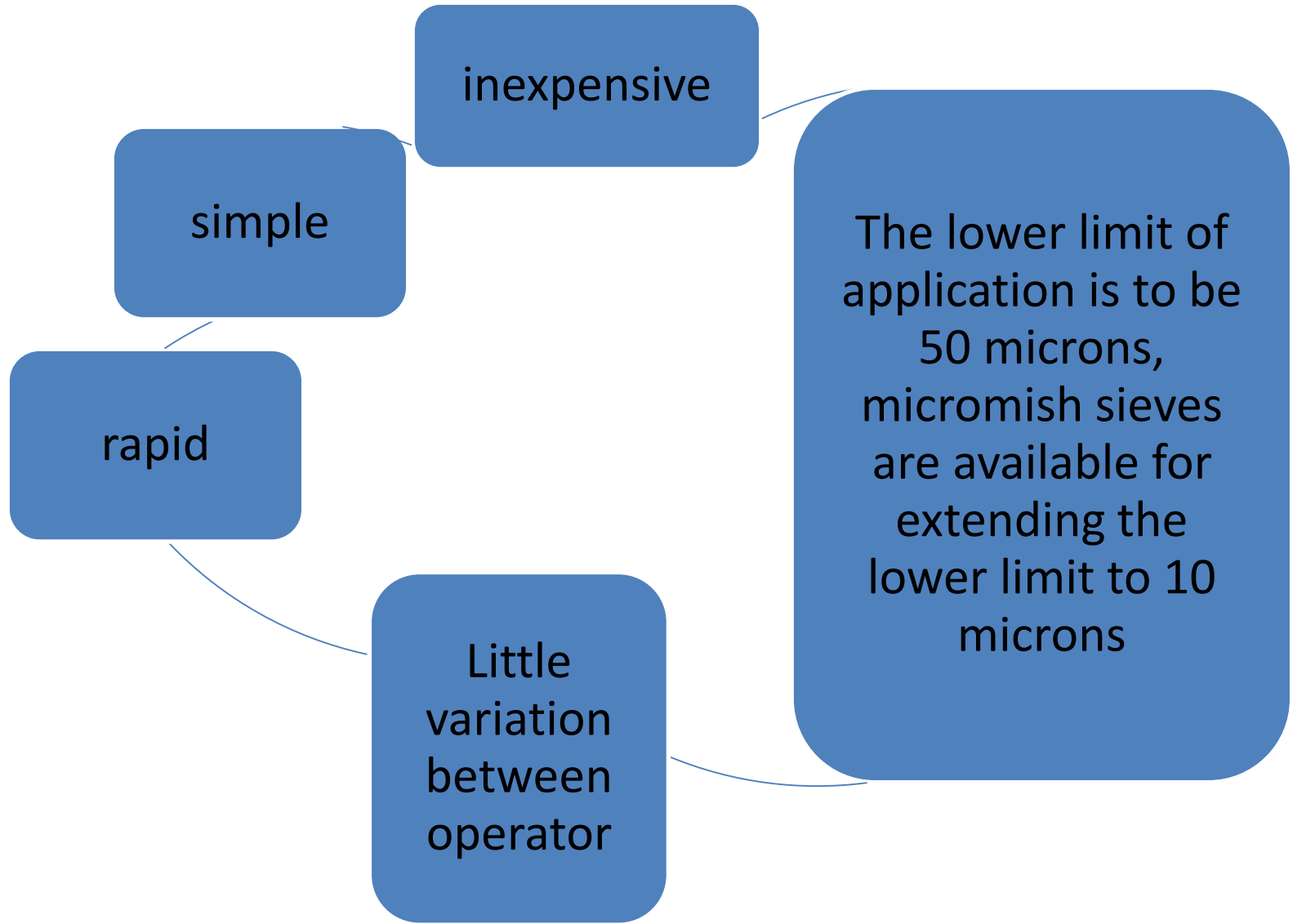

A sieve consist of a pan with a bottom of wire cloth with square openings.

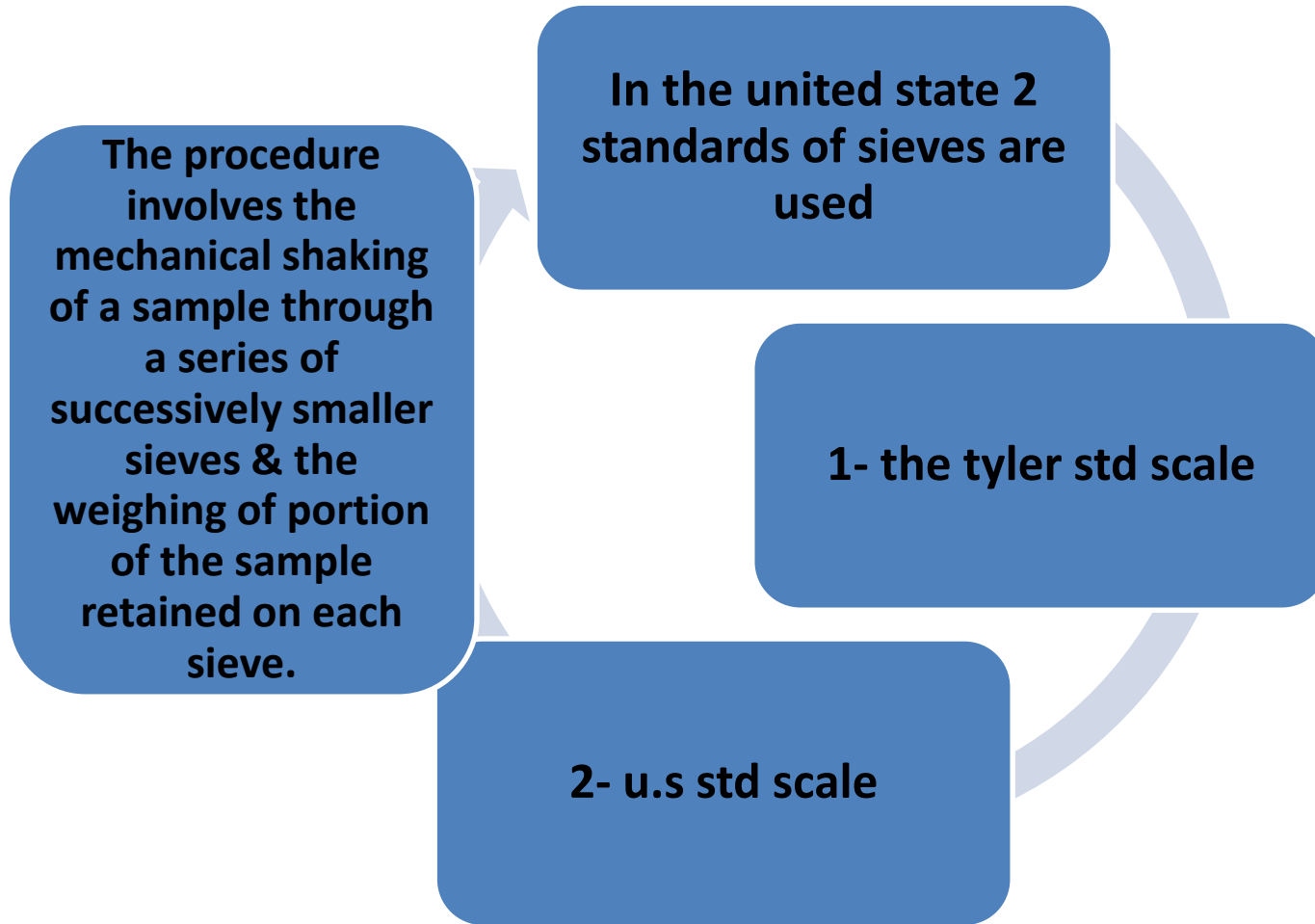

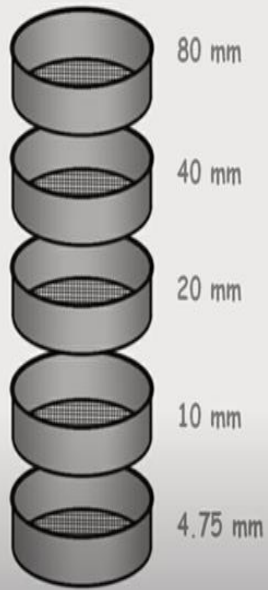

1

Set of coarse sieves



2

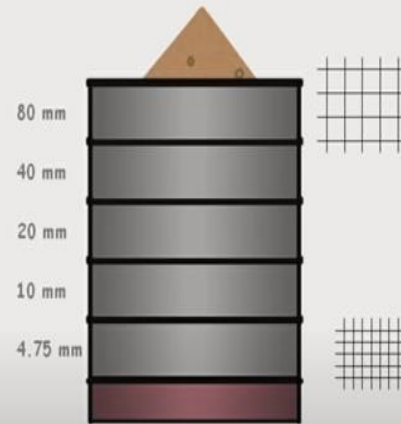

3

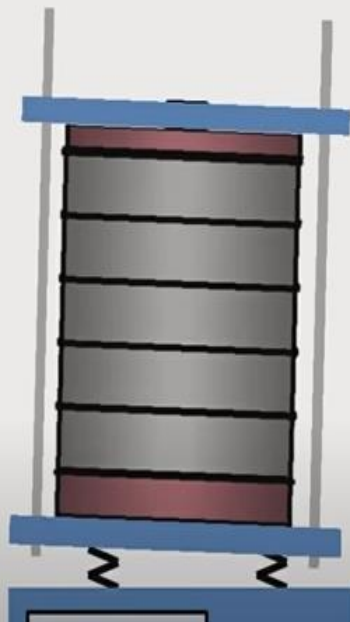

10 minutes shaking

4

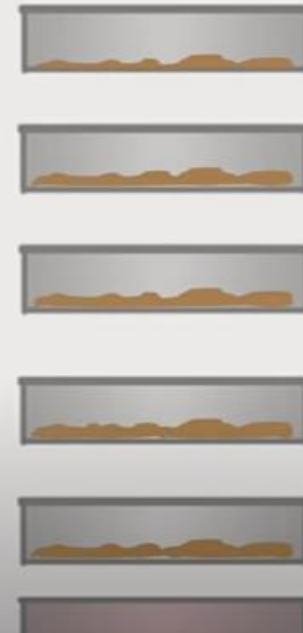

5

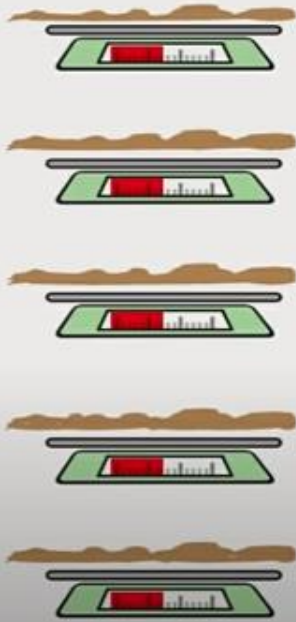

6



% retained on sieve

$$= \frac{\text{Weight of soil retained on sieve}}{\text{Total weight of soil}}$$

7



$$P_1 = \frac{W_1}{W} \times 100$$

$$P_2 = \frac{W_2}{W} \times 100$$

$$P_3 = \frac{W_3}{W} \times 100$$

$$P_4 = \frac{W_4}{W} \times 100$$

$$P_5 = \frac{W_5}{W} \times 100$$

$$W_{pan}$$

Particle Size Distribution Curve

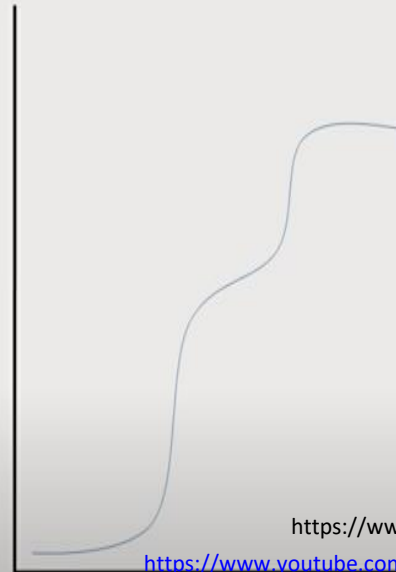

- 1 cumulative percentage retained
- 2 Percentage Finer

<https://www.youtube.com/watch?v=AM-NrQoRIYY>

https://www.youtube.com/watch?v=XbxQ_OiInt4

TABLE 2-4. Designations and Dimensions of U.S. Standard and Tyler Standard Sieves

<i>U.S. Standard</i>		<i>Tyler Standard</i>	
<i>Micron</i>	<i>Mesh</i>	<i>Micron</i>	<i>Mesh</i>
5660	3½	5613	3½
4760	4	4699	4
4000	5	3965	5
3360	6	3327	6
2830	7	2794	7
2380	8	2362	8
2000	10	1651	10
1680	12	1397	12
1410	14	1168	14
1190	16	991	16
1000	18	883	20
840	20	701	24
710	25	589	28
590	30	495	32
500	35	417	35
420	40	351	42
350	45	295	48
297	50	246	60
250	60	208	65
210	70	175	80
177	80	147	100
149	100	124	115
125	120	104	150
105	140	88	170
88	170	74	200

Factors affect on sieving

1-the type of motion influences sieving: vibratory motion is most efficient followed successively by side-tap motion, bottom –tap motion, rotary motion.

2- time is an important factor in sieving

3-the load or thickness of powder per unit area of sieve influences the time of sieving .



https://www.google.com/search?q=pile+on+the+seive&tbm=isch&ved=2ahUKEwiMlvWo-afwAhWNEGMBHTcACcMQ2-cCegQIABAA&oq=pile+on+the+seive&gs_lcp=CgNpbWcQAzoECAAAQzoiCAAQsQMqgwE6BQgAELEDOgIIADoGCAAQBRAeOgYIABAIEB46BAGAEbhQ8oWECFiH0oQIYJjWhAhoAHAeACAAbYBiAH0EZIBBDauMTeYAQCgAQGqAQtnnd3Mtd2l6LWltZ8ABAQ&sclient=img&ei=kAGNYIyOF42hJLsPt4CkmAw&bih=597&biw=1242&hl=en#imgrc=xk35m9MM-9sWAM



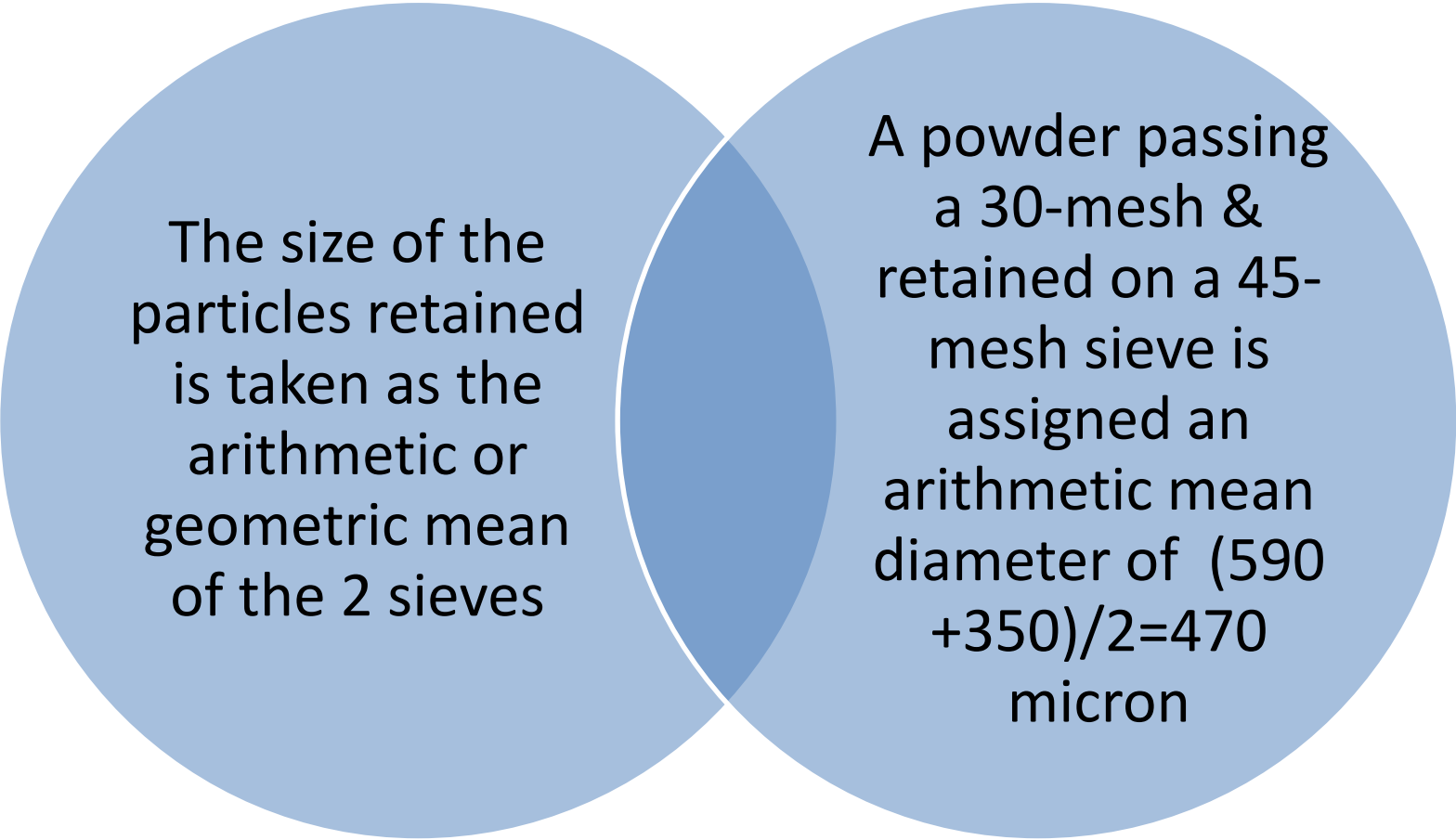

The size of the particles retained is taken as the arithmetic or geometric mean of the 2 sieves

A powder passing a 30-mesh & retained on a 45-mesh sieve is assigned an arithmetic mean diameter of $(590 + 350)/2 = 470$ micron

sedimentation

- May be used over a size range from 1 to 200 microns.
- The sedimentation method is based on the dependence of the rate of sedimentation of the particles on their size as expressed by stokes equation

$$d_{\text{Stokes}} = \sqrt{\frac{18\eta}{(\rho - \rho_0)g} \frac{x}{t}}$$

- This applicable to free spheres that are falling at constant rate.

If the concentration of the suspension does not exceed 2%, there is no significant interaction between the particles & they settle independent of each other.

Anderson method

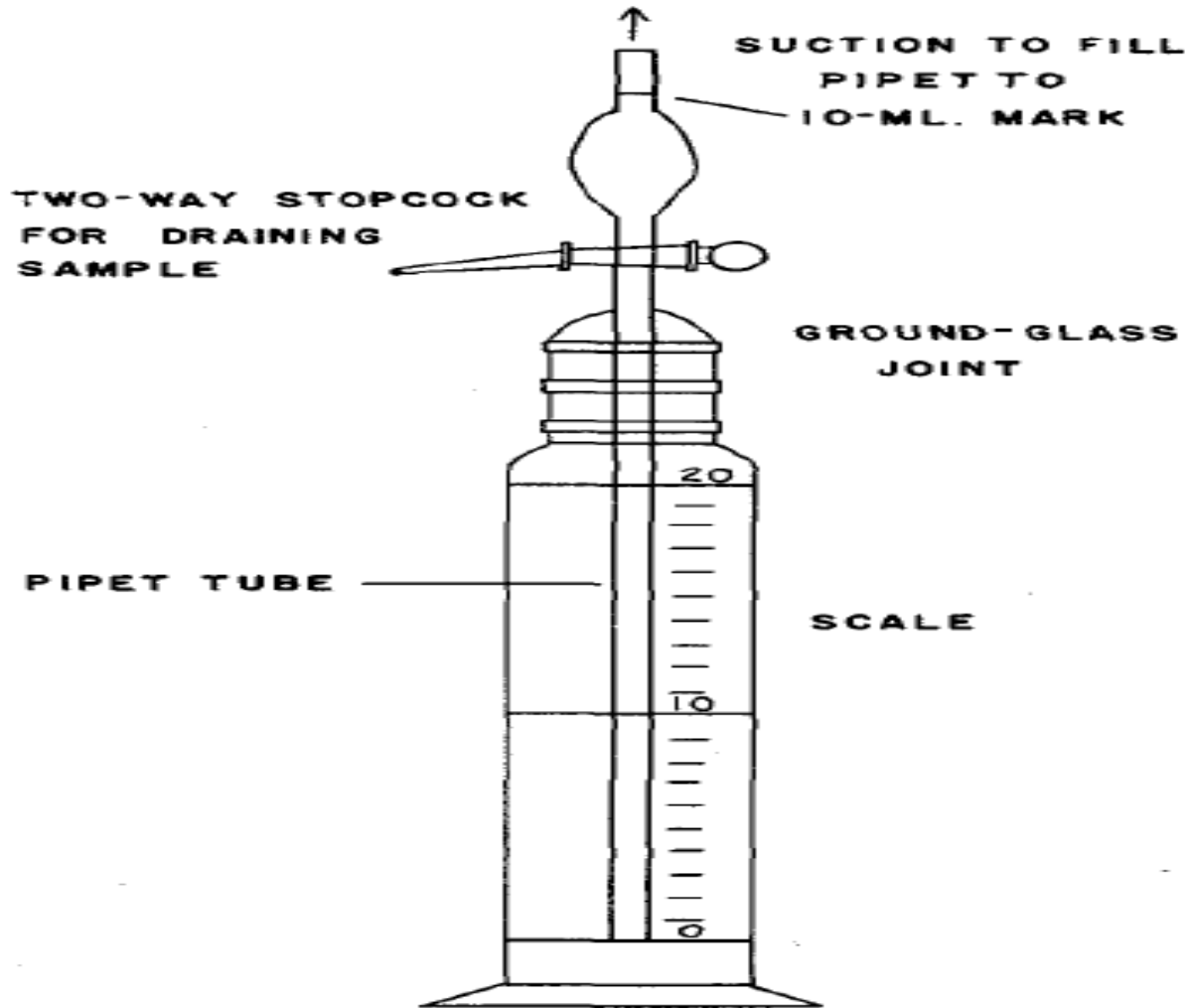

$$d_{\text{Stokes}} = \sqrt{\frac{18\eta}{(\rho - \rho_0)g} \frac{x}{t}}$$

The pipet method (Andreasen) is the simplest means of incremental particle size analysis. A 1% suspension of the powder in a suitable liquid medium is placed in the pipet (Fig. 2-5). At given intervals of time, samples are withdrawn from a specified depth without disturbing the suspension, and they are dried so that the residue may be weighed. By means of Stokes' equation, the particle diameter corresponding to each interval of time is calculated, with x being the height of the liquid above the lower end of the pipet at time t when each sample is withdrawn. As the sizes of the particles are not uniform, the particles settle at different rates. The size-distribution and concentration of the particles vary along the length of the suspension as sedimentation occurs. The larger particles settle at a faster rate and fall below the pipet tip sooner

Theory of comminution

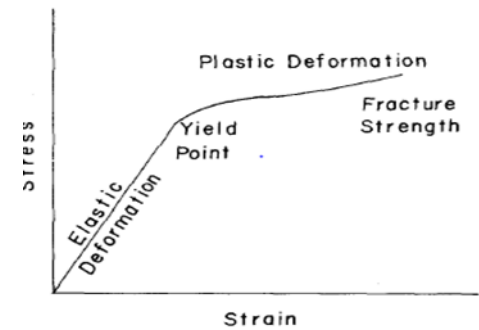
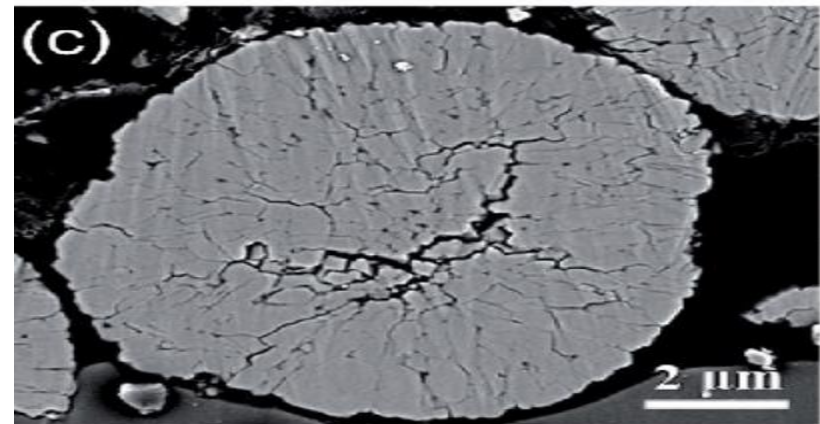

FIG. 2-6. Stress-strain diagram for a solid.

- The mechanical behavior of solids which under the stress are strained & deformed as shown below
- The initial linear portion of the curve is defined by Hooks law (stress is proportional to strain).
- Youngs modulus(slop of linear portion) expresses the stiffness or softness in dynes per square centimeter.
- The stress – strain curve becomes nonlinear at the yield point a measure of the resistance to permanent deformation.
- The area under the curve represents the energy of fracture.

In all milling processes, it is a random matter if and when a given particle will be fractured. If a single particle is subjected to a sudden impact and is fractured, it yields a few relatively large particles and a number of fine particles, with relatively few particles of intermediate size. If the energy of the impact is increased, the larger particles are of a smaller size and more numerous, and although the number of fine particles is increased appreciably, their size is not greatly changed. It seems that the size of the finer particles is related to the internal structure of the material, and the size of the larger particles is more closely related to the process by which comminution is accomplished.

Size reduction begins with the opening of any small cracks that were initially present. Thus, larger particles with numerous cracks fracture more readily than smaller particles with fewer cracks. In general, fine grinding requires more energy, not only because of the increased new surface, but also because more energy is needed to initiate cracks.



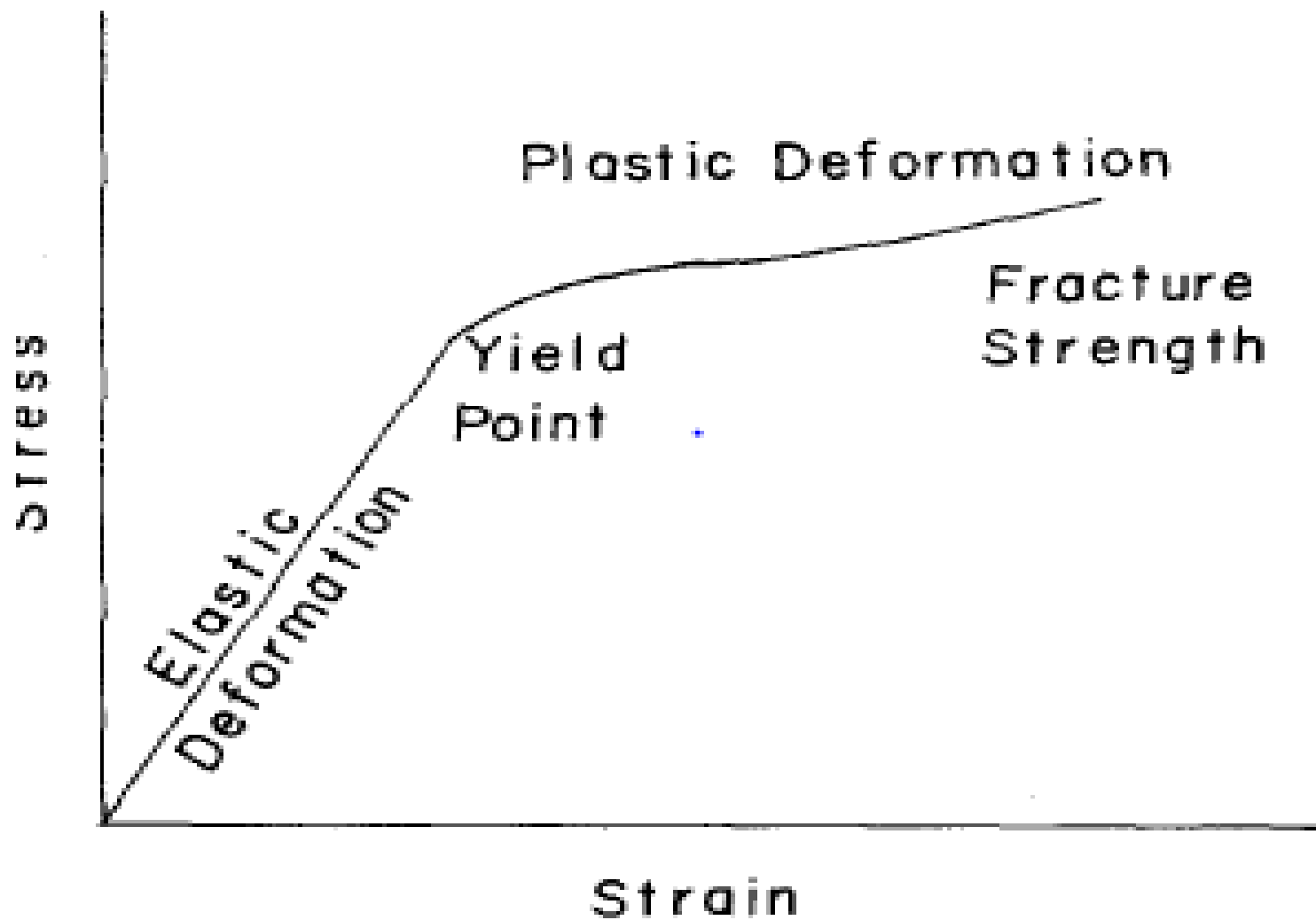

FIG. 2-6. Stress-strain diagram for a solid.

The most efficient mills utilizes less than 1% of the energy input to fracture.

The rest of the energy is dissipated in

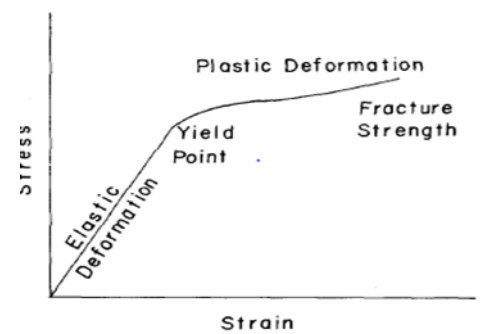

FIG. 2-6. Stress-strain diagram for a solid.

1- Elastic deformation of unfractured particles

2-Transport of material within the milling chamber

3-Friction between particles

4-Friction between particles & mill

5- Heat

6- Vibration & noise

7-Inefficiency of transmission & motor

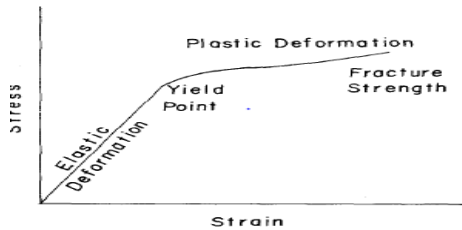
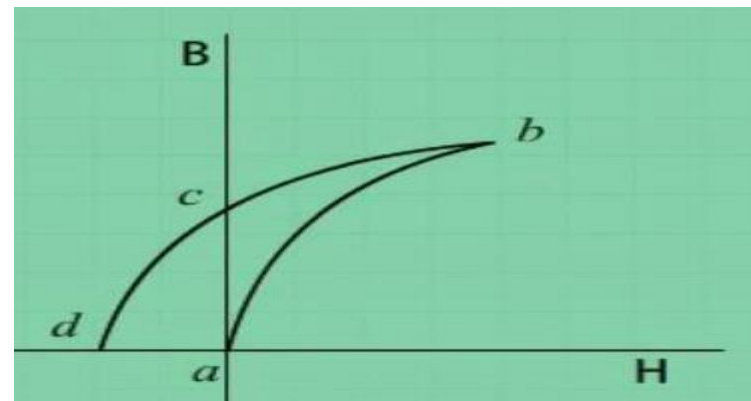

FIG. 2-6. Stress-strain diagram for a solid.



If the force of impact does not exceed the elastic limit (region of Hookes law) ,the material is reversibly deformed or stressed.

When the force is removed ,the particle returns to its original condition, & the mechanical energy of stress in the deformed particle appear as heat.

For polymeric material hysteresis is frequent occurs in the stress strain cycle the area of the loop represents the dissipation of stress energy(usually heat).

A force that exceeds the elastic limit fractures the particle. Usually, the surfaces of particles are irregular, so that the force is initially taken on the high portion of the surface, with the result that high stresses and temperatures may be set up locally in the material.

As fracture occurs the points of application of the force are shifted. The energy for the new surfaces is partially supplied by the release of stress energy.

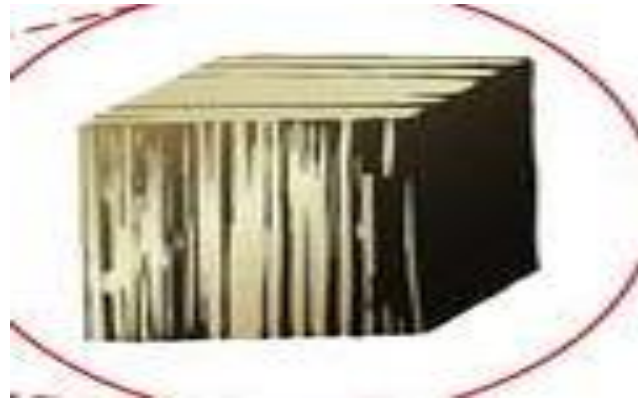

Crystalline materials fracture along crystal cleavage planes; noncrystalline materials fracture at random. If an ideal crystal were pressed with an increasing force, the force would be distributed uniformly throughout its structure until the crystal disintegrated into its individual units.

A real crystal fractures under much less force into a few relatively large particles and several fine particles, with relatively few particles of intermediate size.

Crystals of pure substances have internal weaknesses due to missing atoms or ions in their lattice structures and to flaws arising from mechanical or thermal stress.

A flaw in a particle is any structural weakness that may develop into a crack under strain. It has been proposed that any force of milling produces a small flaw in the particle. The useful work in milling is proportional to the length of new cracks produced. A particle absorbs strain energy and is deformed under shear or compression until the energy exceeds the weakest flaw and causes fracture or cracking of the particle.

Energy of comminution

- The energy required to reduce the size of particles is inversely proportional to the size raised to some power. This may be expressed mathematically as:

$$\frac{dE}{dD} = -\frac{C}{D^n} \quad (15)$$

Where dE is the amount of energy required to produce a change in size, dD , of unit mass of material & where C & n are constants.

Types of mills

a mill consist of 3 basic parts

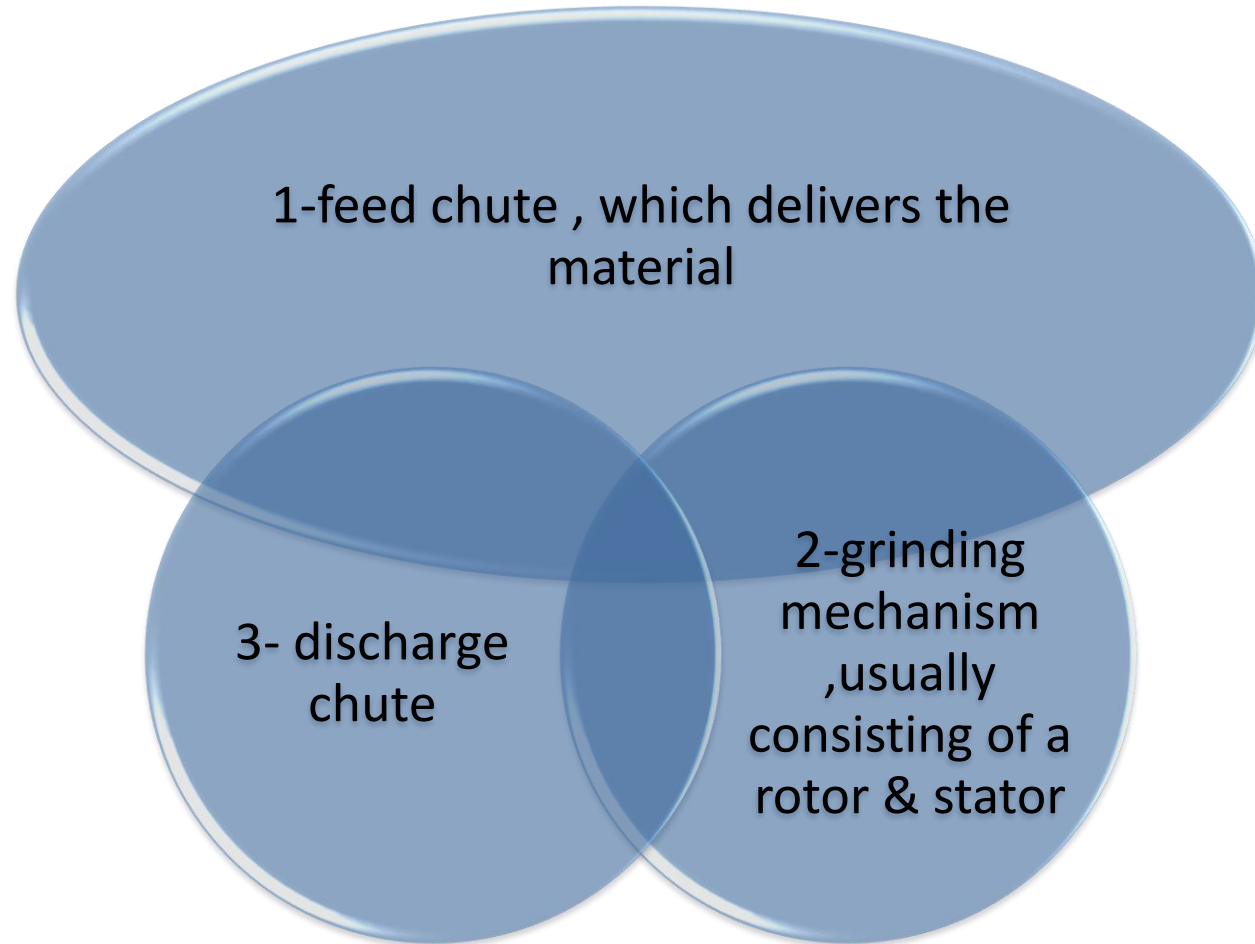

- The principle of operation depends on direct pressure ,impact from a sharp blow, attrition or cutting .
- In most mills the grinding effect is a combination of these actions.
- The manner in which the operator feeds a mill markedly affects the product.
- 1- If the rate of feed is slow, the product discharged readily & the amount of undersize or fines is minimized.
- 2- If the mill is choke fed at a fast rate , the material is in the milling chamber for a long time as its discharge

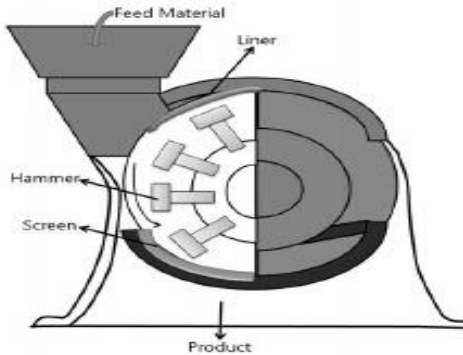

- is impeded by the mass of material. This provide a greater reduction of particle size but the capacity of the mill is reduced & power consumption is increased.
- Choke feed is used when a small amount of material is to be milled in one operation.
- **The rate of discharge should be equal to the rate of feed, which is such that the milling parts can operate most effectively.**

Hammer mill

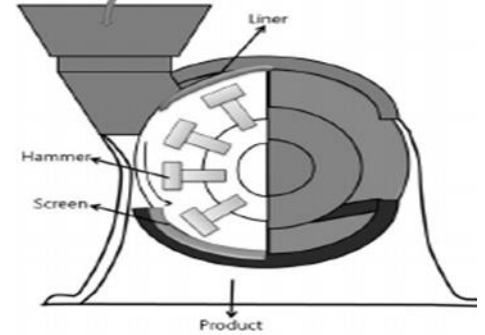

- The hammer mill is an impact mill using a high speed rotor to which a no. of swinging hammers are fixed.
- The material is fed at the top or center, thrown out centrifugally, & ground by impact of the hammers or against the plates around the periphery of the casing.
- The clearance between the housing and the hammers contributes to the size reduction. The material retained until it is small enough to fall through the screen.
- Particles fine enough to pass through the screen.
- The hammer mill versatility makes it use to mill dry materials, wet filter press cakes, ointments & slurries .
- The size of the product size is controlled by selecting the speed of hammers & the size & type of screen.

Brittle material is best fractured by impact from a blunt hammer; fibrous material is best reduced in size by cutting edges. Some models of hammer mills have a rotor that may be turned 180 degrees to allow use of either the blunt edge for fine grinding or the knife edge for cutting or granulating.

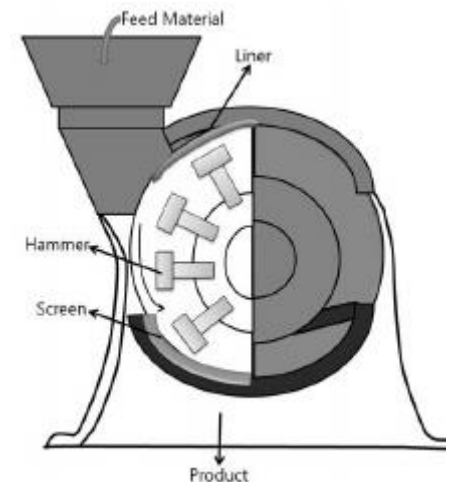
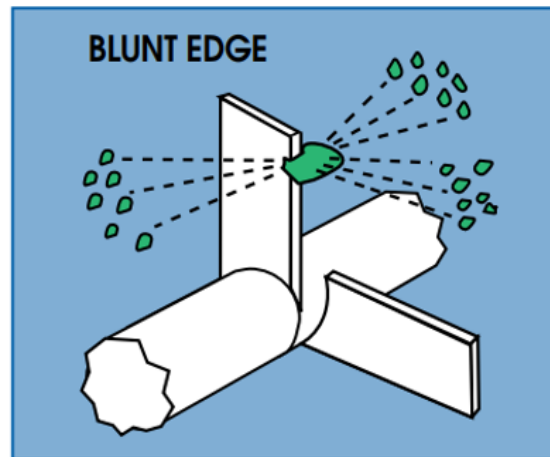
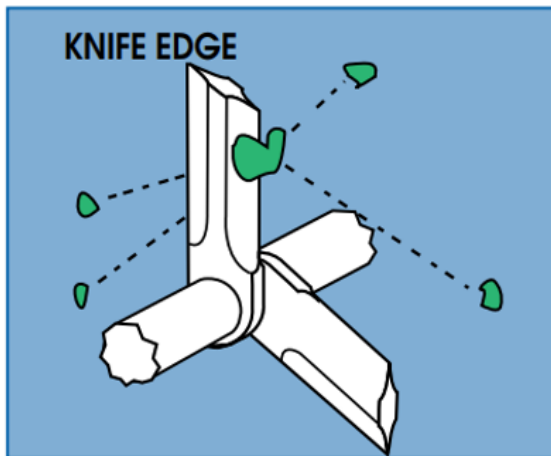

https://www.google.com/search?q=hammer+mill+blunt+knife&tbm=isch&ved=2ahUKewj43JnV4KjwAhU6DmMBHVjkC1AQ2-cCegQIABAA&ooq=hammer+mill+blunt+knife&gs_lcp=CgNpbWcQAzoeCAAQZoCCAA6BggAEAgQHjoECAAQGFCBndY6MUXYOXIF2gAcAB4AIABqQWIAeMTkgELMC45LjEuMS4wLjGYAQcAQGqAQtdn3Mtd2l6LWltZ8ABAQ&scIent=img&ei=7m2NYPitBrqjLsP2MivgAU&bih=597&biw=1242&hl=en#imgrc=7PGf3Tc7OWN8dM

A hammer mill can be used for granulation and close control of the particle size of powders. The size of the product is controlled by selecting the speed of the hammers and the size and type of the screen. Speed is crucial. Below a critical impact speed, the rotor turns so slowly that a blending action rather than comminution is obtained. This results in overloading and a rise in temperature. Microscopic examination of the particles formed when the mill is operating below the critical speed shows them to be spheroidal, indicating not an impact action, but an attrition action, which produces irregularly shaped particles. At very high speeds, there is possibly insufficient time between hammers for the material to fall from the grinding zone. In wet milling of dispersed systems with higher speeds, the swing hammers may lay back with an increased clearance; for such systems, fixed hammers would be more effective.

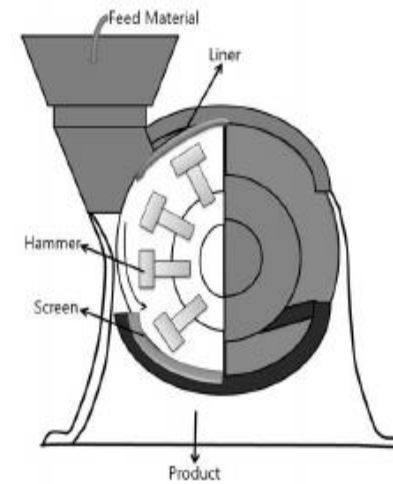
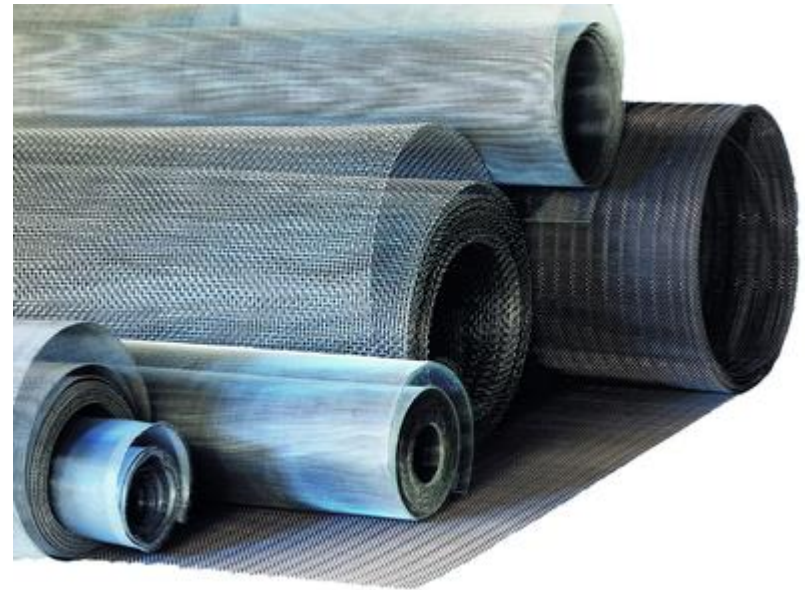

Figure 2-12 shows the influence of speed on the particle size-frequency curves for boric acid milled at 1000, 2450, and 4600 rpm in a hammer mill fitted with a screen having 6.35-mm circular holes.

The screens that retain the material in the milling chamber are not woven but perforated. The particle size of the discharged material is smaller than the screen hole or slot, as the particles exit through the perforation on a path approximately tangential to the rotor. For a given screen, a smaller particle size is obtained at a higher speed, as is shown in Figure 2-13. Efforts to strengthen a screen by increasing its thickness influence particle size. For a given rotor speed and screen opening, a thicker screen produces a smaller particle, which is also illustrated in Figure 2-13.



https://www.google.com/search?q=seives+of+solid+fbrics&tbm=isch&ved=2ahUKEwjK_PuO4qjwAhXK_IUKHX72AngQ2-cCegQIABAA&oeq=seives+of+solid+fbrics&gs_lcp=CgNpbWcQAzoECAAQZoFCAAQsQM6AggAOgclABCxAXBDogYIABAFEB46BggAEAoQGDoECAAQDoGCAAQCBAeULGZOFjy_Thg3YA5aABwAHgAgAGQAYgBhheSAQQwLjlymAEAoAEBqgELZ3dzLXdpei1pbWFAAQE&sclient=img&ei=c2-NYIr3Kcr5lwT-7IvABw&bih=597&biw=1242&hl=en#imgrc=0_d02Xsl4q4_iM

https://www.google.com/search?q=seives+of+solid+fbrics&tbm=isch&ved=2ahUKEwjK_PuO4qjwAhXK_IUKHX72AngQ2-cCegQIABAA&oeq=seives+of+solid+fbrics&gs_lcp=CgNpbWcQAzoECAAQZoFCAAQsQM6AggAOgclABCxAXBDogYIABAFEB46BggAEAoQGDoECAAQDoGCAAQCBAeULGZOFjy_Thg3YA5aABwAHgAgAGQAYgBhheSAQQwLjlymAEAoAEBqgELZ3dzLXdpei1pbWFAAQE&sclient=img&ei=c2-NYIr3Kcr5lwT-7IvABw&bih=597&biw=1242&hl=en#imgrc=kArt33edFoMdyM

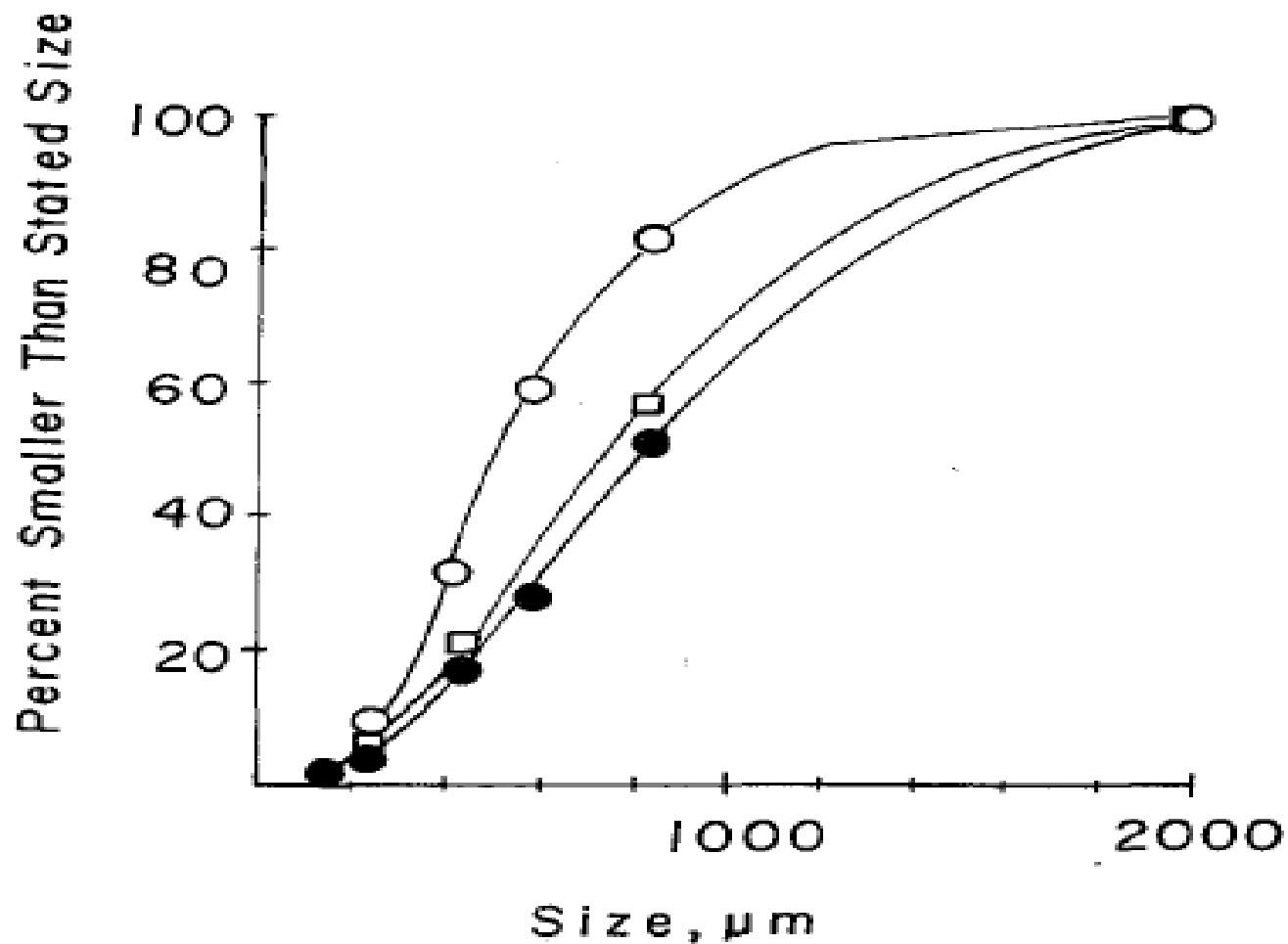

FIG. 2-12. Influence of speed on the size-frequency distribution of boric acid flakes milled by a hammer mill operating with impact edge forward and fitted with a round hole No. 4 screen (hole diameter: 6.35 mm). Key: ●, 1000 rpm; □, 2450 rpm; and ○, 4600 rpm.

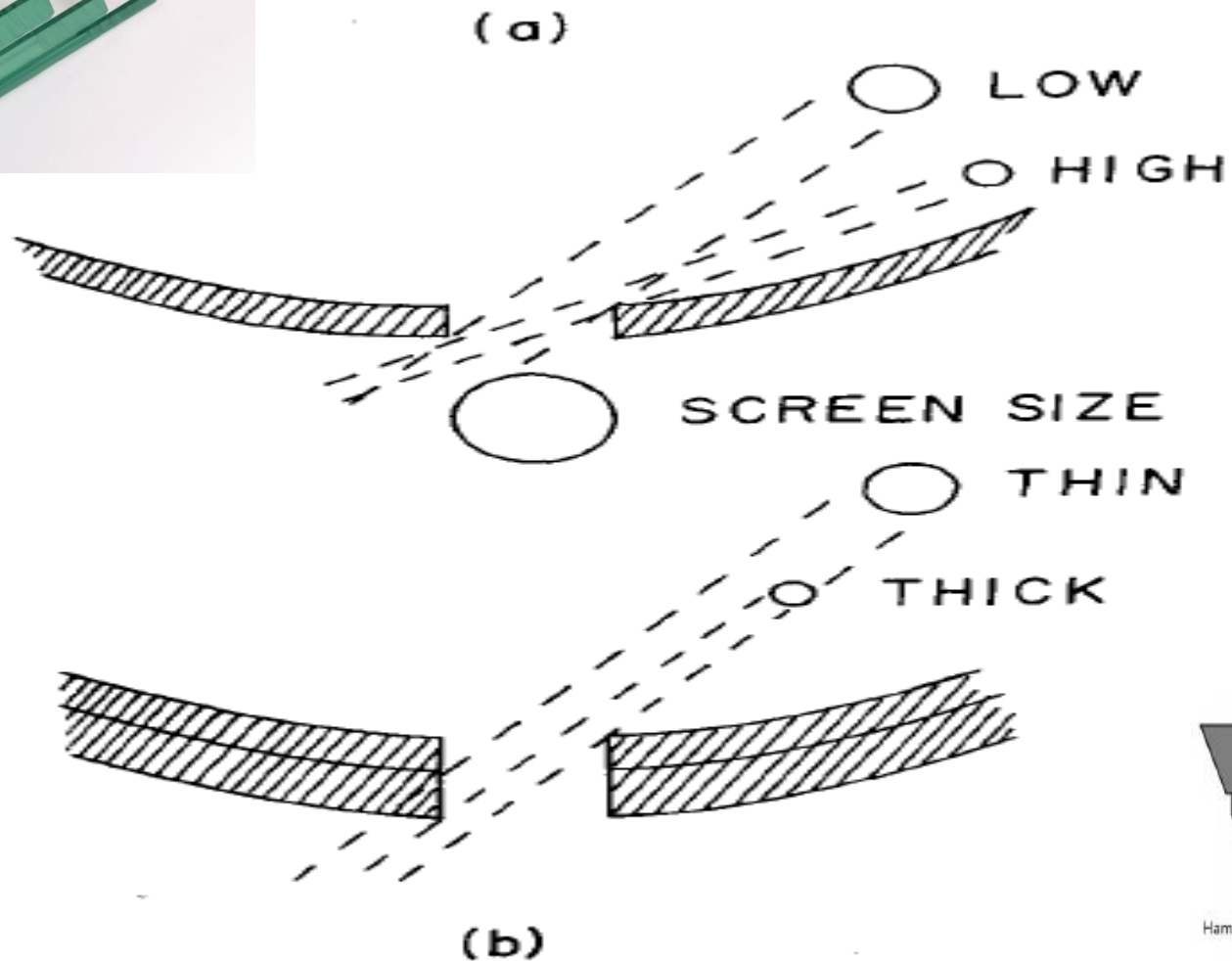
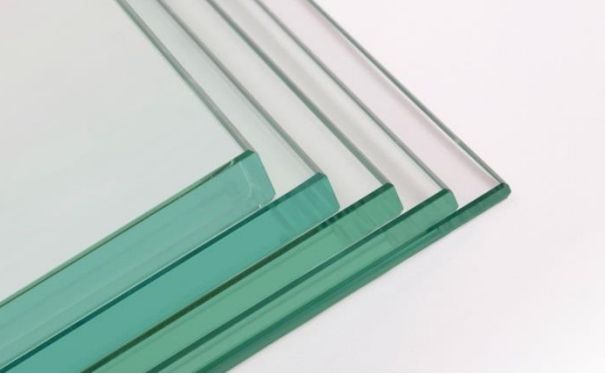
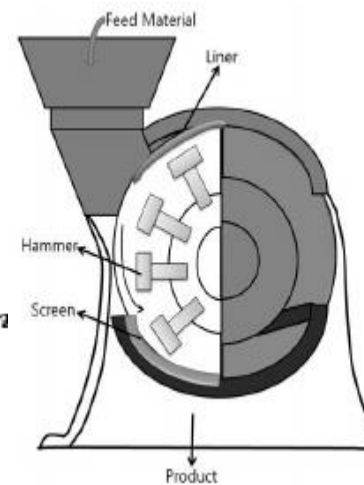

FIG. 2-13. In a hammer mill, particle size is influenced by speed (a) and thickness of screen (b).



narrow size distribution. Hammer mills are simple to install and operate. The speed and screen can be rapidly changed. They are easy to clean and may be operated as a closed system to reduce dust and explosion hazards.

