

## Alkyl Halides

Alkyl halides are a class of compounds where a halogen atom or atoms are bound to an  $sp^3$  orbital of an alkyl group.

$CHCl_3$  (Chloroform: organic solvent)

$CF_2Cl_2$  (Freon-12: refrigerant CFC)

$CF_3CHClBr$  (Halothane: anesthetic)

Halogen atoms are more electronegative than carbon atoms, and so the C-Hal bond is polarized.

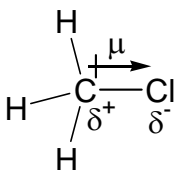

The C-X bond is polarized in such a way that there is partial positive charge on the carbon and partial negative charge on the halogen.

Dipole moment,  $\mu = 4.8 \times \delta \times d$

$\delta$  = charge

$d$  = bond length.

Electronegativities **decrease** in the order of:

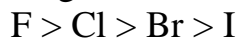

Carbon-halogen bond lengths **increase** in the order of:

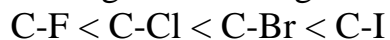

Bond Dipole Moments decrease in the order of:

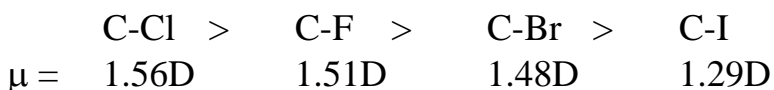

Typically the chemistry of alkyl halides is dominated by this effect, and usually results in the C-X bond being broken (either in a substitution or elimination process).

This reactivity makes alkyl halides useful chemical reagents.

### Nomenclature

According to IUPAC, alkyl halides are treated as alkanes with a halogen substituent.

The halogen prefixes are Fluoro-, Chloro-, Bromo- and Iodo-.

Examples:

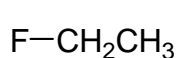

fluoroethane

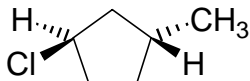

trans-1-chloro-3-methylcyclopentane

Often compounds of  $\text{CH}_2\text{X}_2$  type are called methylene halides. ( $\text{CH}_2\text{Cl}_2$  is methylene chloride).

$\text{CHX}_3$  type compounds are called haloforms. ( $\text{CHI}_3$  is iodoform).

$\text{CX}_4$  type compounds are called carbon tetrahalides. ( $\text{CF}_4$  is carbon tetrafluoride).

Alkyl halides can be primary ( $1^\circ$ ), secondary ( $2^\circ$ ) or tertiary ( $3^\circ$ ).

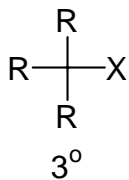
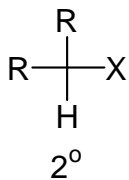
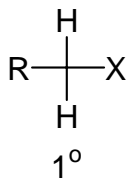

### Other types:

A geminal (gem) dihalide has two halogens on the same carbon.

A vicinal dihalide has halogens on adjacent carbon atoms.

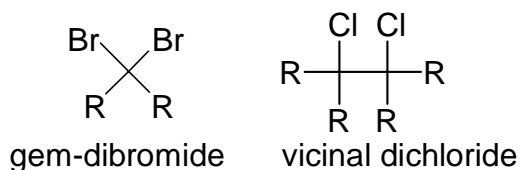

### Preparation of Alkyl Halides

Numerous ways to make alkyl halides.

#### (1a) Free Radical Halogenation

Usually this method gives mixtures of mono-, di-, tri- etc halogenated compounds, which is considered an inefficient method for the synthesis of a desired compound.

Consider propane:

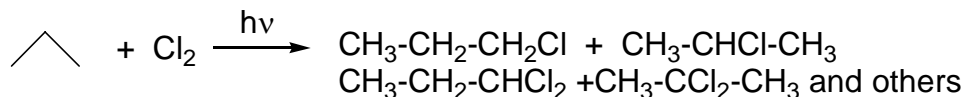

Sometimes if there can be **control** over the selectivity of halogenation this is a useful route.

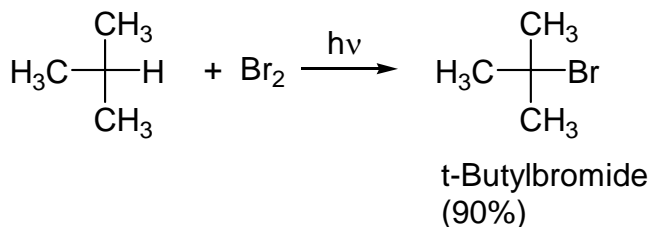
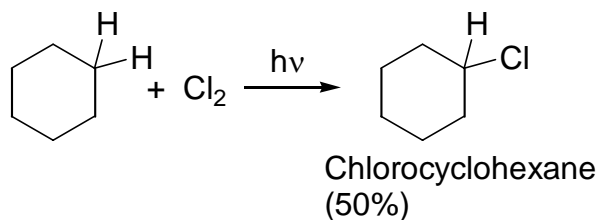

### (1b) Allylic Bromination

(Allylic means adjacent to a C=C double bond)

The bromination of cyclohexene produces a high yield of 3-bromocyclohexene.

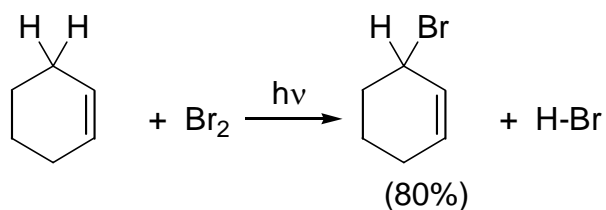

An allylic hydrogen has been substituted for a bromine.

The bromine atom abstracts an allylic hydrogen because the allylic radical is resonance stabilized.

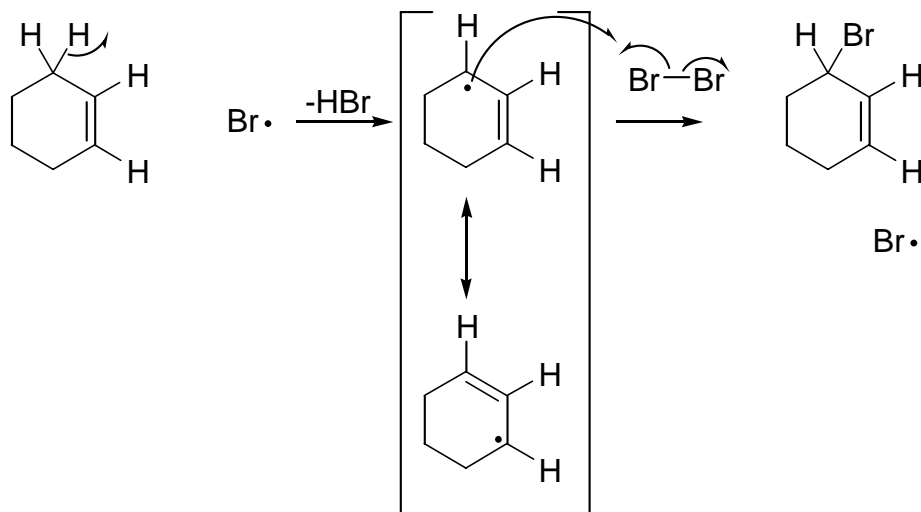

The radical then reacts with a bromine molecule to continue the chain.

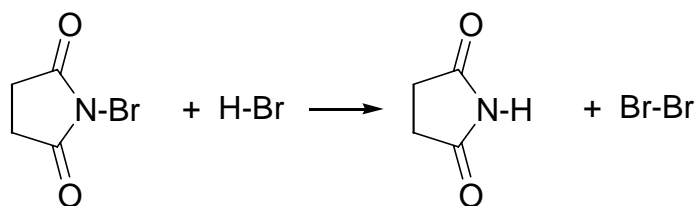

A common reagent for these allylic brominations is N-bromosuccinamide (NBS) because it continually generates small amounts of Br<sub>2</sub> through reaction with HBr.

### Other methods for Preparation

(These will be covered in detail in appropriate later chapters).

From alkenes and alkynes:

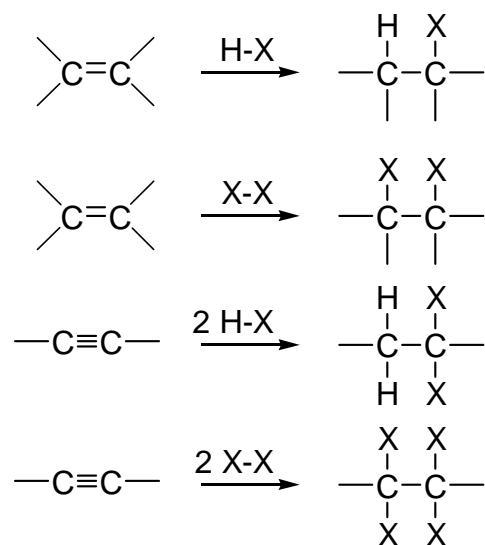

From alcohols:

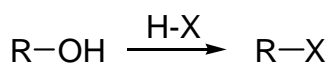

From other halides:

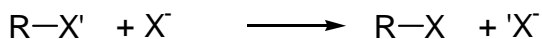

### Reactions of Alkyl Halides

The alkyl halides are chemically versatile.

The halogen atom may leave with its bonding pair of electrons to give a halide ion which is stable – a halide is called a **good leaving group**.

If an atom replaces the halide the overall reaction is a substitution.

If the halide loss is accompanied by the loss of another atom, the overall reaction is called an **elimination**.

Very often the other atom lost is a hydrogen (as  $H^+$ ). The elimination of  $H-X$  is common, and is called a **dehydrohalogenation**.

Often substitution and elimination reactions will occur in competition with each other.

### Nucleophilic Substitution

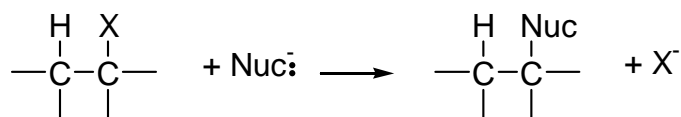

The nucleophile  $\text{Nuc:}^-$  displaces the leaving group  $\text{X}^-$  from the carbon atom by using its lone pair to form a new bond to the carbon atom.

### Elimination

A new  $\pi$  bond is formed by the elimination of halide ion and another atom (usually  $H^+$ ).

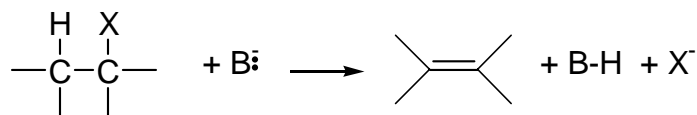

In a dehydrohalogenation, the base ( $\text{B:}^-$ ) abstracts a proton from the alkyl halide.

Most nucleophiles can also act as bases, therefore the preference for elimination or substitution depends on the reaction conditions and the alkyl halide used.

### The $S_N2$ reaction

$S_N2$  means substitution nucleophilic bimolecular.

Consider the reaction of hydroxide ion with methyl iodide, to yield methanol.

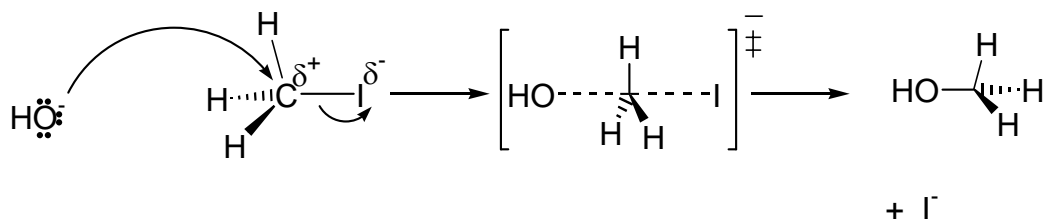

The hydroxide ion is a good nucleophile since the oxygen atom has a negative charge and a pair of unshared electrons.

The carbon atom is electrophilic since it is bound to a (more electronegative) halogen, which pulls electron density away from the carbon, thus polarizing the bond with carbon bearing partial positive charge and the halogen bearing partial negative charge.

The nucleophile is attracted to the electrophile by electrostatic charges.

The nucleophile attacks the electrophilic carbon through donation of 2 electrons.

Carbon can only have a maximum of 8 valence electrons, so as the carbon-nucleophile bond is forming, then the carbon-leaving group bond must be breaking.

Iodide is the leaving group since it leaves with the pair of electrons that once bound it to carbon.

The reaction is said to be concerted, taking place in a single step with the new bond forming as the old bond is breaking.

The transition state is a point of highest energy (not an intermediate).

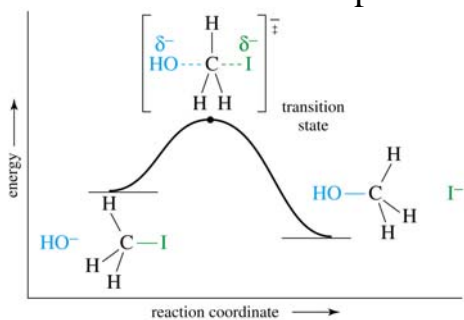

Kinetic information tells us that the rate is doubled when the  $[\text{CH}_3\text{I}]$  is doubled, and also doubled when the  $[\text{HO}^-]$  is doubled.

The rate is first order w.r.t. both reactants and is therefore 2<sup>nd</sup> order overall.



The rate and mechanism are consistent since the mechanism requires a collision between the hydroxide ion and methyl iodide. Both species are present in the transition state, and the frequency of collisions is proportional to the concentrations of the reactants.

$\text{S}_{\text{N}}2$  = substitution, nucleophilic, bimolecular.

Bimolecular means that the transition state of the R.D.S. involves the collision of two molecules. (Bimolecular reactions generally have 2<sup>nd</sup> order overall rate equations).

#### Versatility of the $\text{S}_{\text{N}}2$ mechanism

The  $\text{S}_{\text{N}}2$  mechanism is a common reaction mechanism and can cover a variety of functional group transformations of alkyl halides.

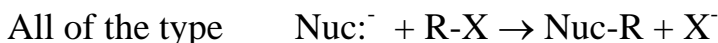

	Nucleophile		Product	Class
R-X	+ $\text{I}^-$	→	R-I	alkyl halide
R-X	+ $\text{HO}^-$	→	R-OH	alcohol
R-X	+ $\text{R}'\text{O}^-$	→	R-O-R'	ether
R-X	+ $\text{HS}^-$	→	R-SH	thiol
R-X	+ $:\text{NH}_3$	→	R-NH <sub>2</sub>	amine
R-X	+ $\text{N}_3^-$	→	R-N <sub>3</sub>	azide
R-X	+ $^- \text{C} \equiv \text{C}-\text{R}'$	→	R-C≡C-R'	alkyne
R-X	+ $^- \text{CN}$	→	R-C≡N	nitrile
R-X	+ $\text{R}'\text{CO}_2^-$	→	R-CO <sub>2</sub> R'	ester
R-X	+ $:\text{P}(\text{Ph})_3$	→	$(\text{R}-\text{PPh}_3)^+ \text{X}^-$	phosphonium salt
R-X	+ $\text{R}'\text{S}^-$	→	R-S-R'	thioether



Halogen exchange reactions are normally used to prepare either iodo- or fluoro- compounds from other alkyl halides since direct iodination is too slow and direct fluorination is too violent.

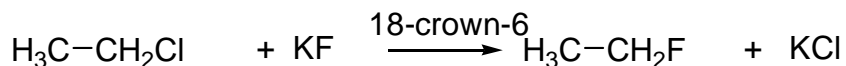
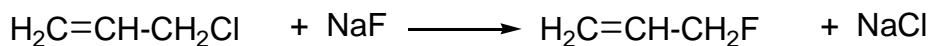

### Nucleophile Strength

The rate of the  $\text{S}_{\text{N}}2$  reaction strongly depends on the nature of the nucleophile – a good nucleophile gives faster rates than a worse nucleophile.

Consider methanol ( $\text{CH}_3\text{OH}$ ) and methoxide ( $\text{CH}_3\text{O}^-$ ) reacting with  $\text{CH}_3\text{I}$ . It is found that methoxide reacts about a million times faster in  $\text{S}_{\text{N}}2$  reactions than methanol.

Generally negatively charged species are much better nucleophiles than analogous neutral species.

The two transition states are different energetically.

The T.S. with methoxide has the negative charge shared over the oxygen atom and the leaving halide.

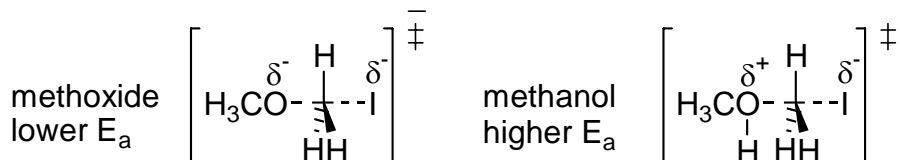

In the methanol case, there is no negative charge. The halide has a partial negative charge and the oxygen has a partial positive charge. This is of higher energy.

## Basicity and Nucleophilicity

Basicity is defined by the equilibrium constant for abstracting a proton.

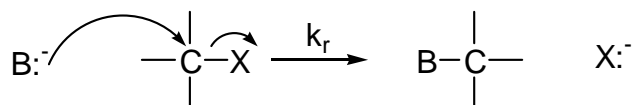
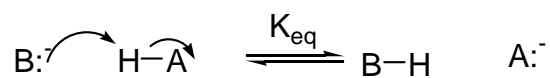

Nucleophilicity is defined by the rate of attack on an electrophilic carbon atom.

## Trends in Nucleophilicity

- 1) Species with a negative charge are stronger nucleophiles than analogous species without a negative charge. (Bases are always stronger nucleophiles than their conjugate acids).

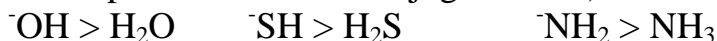

- 2) Nucleophilicity decreases from left to right across the periodic table. (The more electronegative elements hold on more tightly to their non-bonding electrons).



- 3) Nucleophilicity increases down the periodic table. (Increase in polarizability and size).



As the size of an atom increases, its outer electrons get further from the attractive force of the nucleus. The electrons are held less tightly and are said to be more polarizable – they are more able to move toward a positive charge.

More polarizable atoms can form bonds at greater distances, which gives rise to stronger bonding in the T.S.

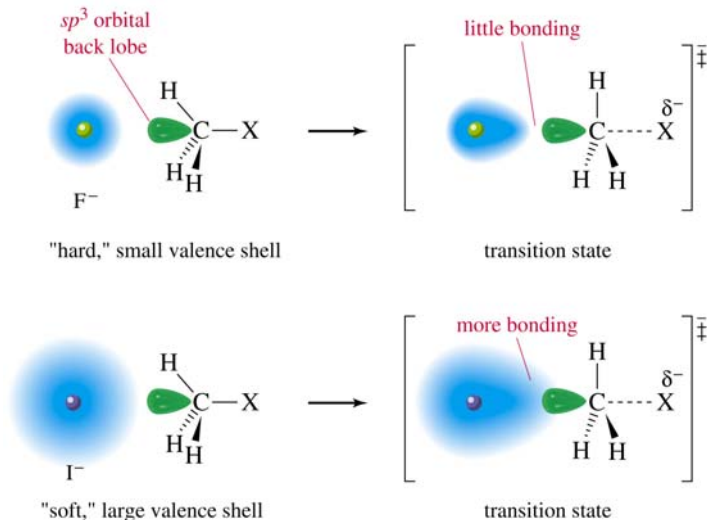

Fluoride is a “hard” or low polarizability nucleophile, with its electrons held close to the nucleus, and it must approach the carbon nucleus closely before orbital overlap can occur.

The outer shell of the “soft” iodide has loosely held electrons, and these can easily shift and overlap with the carbon atom at a relatively far distance.

### Effect of Solvents

Different solvents have different effects on the nucleophilicity of a species.

Solvents with acidic protons are called protic solvents (usually O-H or N-H groups).

Polar, protic solvents are often used for  $S_N2$  reactions, since the polar reactants (nucleophile and alkyl halide) generally dissolve well in them.

Small anions are much more strongly solvated than larger anions, and sometimes this can have an adverse effect.

Certain anions, like  $F^-$ , can be solvated so well in polar protic solvents that their nucleophilicity is reduced by the solvation.

For efficient  $S_N2$  reactions with small anions it is usual to use polar aprotic solvents.

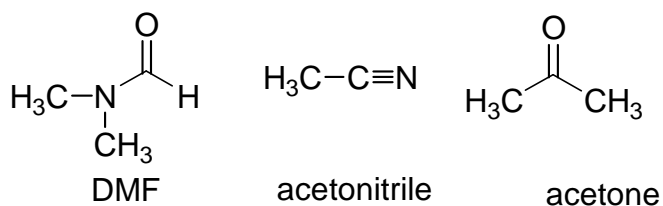

The solvents are still polar, but have no O-H or N-H bonds to form hydrogen bonds to the small anions.

### Steric Effects

In general, the steric bulk has a detrimental effect on nucleophilicity.

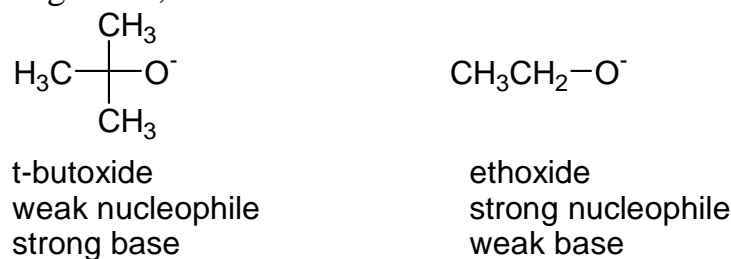

Since nucleophilicity involves the attack of the nucleophile at a carbon center, large groups tend to hinder this process.

Steric effects are not as important for basicity since this involves the abstraction of an unhindered proton.

### Substrate Effects

- leaving group effects
- steric effects

### Leaving group effects

A good leaving group has the following features:

- (1) Electron withdrawing (to polarize the C-X bond, making the C electrophilic).
- (2) Stable once it has left (not a strong base).
- (3) Polarizable (to stabilize the T.S. – like I<sup>-</sup> previously)

Common leaving groups:

- (ions) Cl<sup>-</sup>, Br<sup>-</sup>, I<sup>-</sup>, RSO<sub>3</sub><sup>-</sup> (sulfonate), RSO<sub>4</sub><sup>-</sup> (sulfate), RPO<sub>4</sub><sup>-</sup> (phosphate).  
 (neutral) H<sub>2</sub>O, R-OH, R<sub>3</sub>N, R<sub>3</sub>P.

Hydroxide ions are not good leaving groups (strong bases), but in acidic media, the O gets protonated, and now H<sub>2</sub>O can serve as a good leaving group.

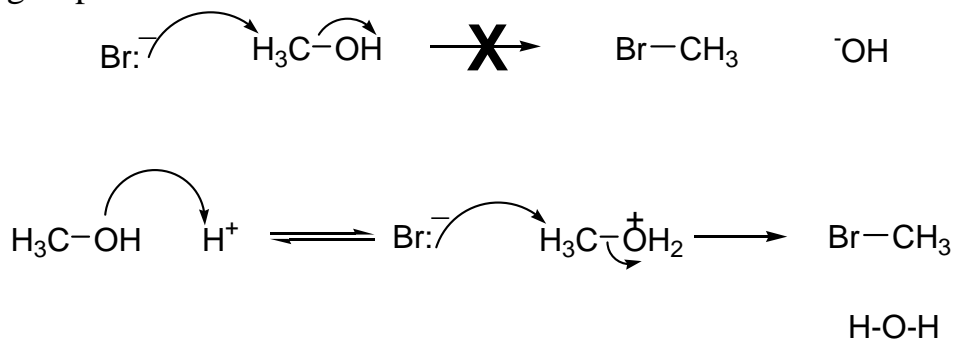

Neutral molecules can be good leaving groups from positively charged electrophiles. But the need to protonate the electrophile first limits the choice of nucleophiles to those that are not strong bases, since the nucleophile would simply get protonated.

### Steric Effects of the Substrate

Large groups on the electrophile hinder the approach of the nucleophile.

Rel. rates for S<sub>N</sub>2: CH<sub>3</sub>X > 1° > 2° > 3° alkyl halides.

For an S<sub>N</sub>2 reaction, the nucleophile must approach the small backside lobe of the C-X sp<sup>3</sup> orbital.

Generally, one alkyl group slows the reaction, two alkyl groups make it difficult, three alkyl groups close to impossible.

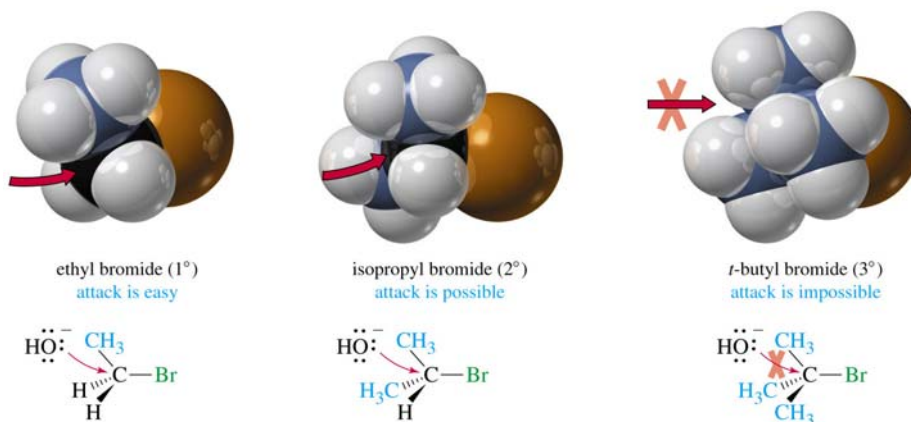

## Stereochemistry of the S<sub>N</sub>2 Reaction

A nucleophile donates its electron density into (attacks) the small back lobe of the sp<sup>3</sup> hybridized C-X bond, since the leaving group itself blocks attack from any other direction. This is called back side attack.

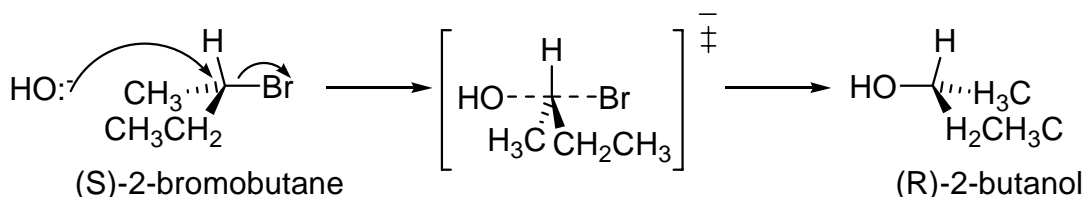

The product has its stereochemistry inverted by an S<sub>N</sub>2 reaction.

The S<sub>N</sub>2 reaction is called a **stereospecific** reaction since a certain stereoisomer reacts to give one specific stereoisomer as product. (S<sub>N</sub>2 reactions always proceed with inversion).

## First Order Nucleophilic Substitution

There is also an S<sub>N</sub>1 reaction. (Substitution, nucleophilic, unimolecular).

Consider the reaction of t-butylbromide and methanol:

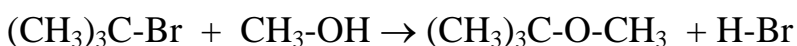

The rate was found to depend only on the concentration of t-butylbromide.

$$\text{Rate} = k_r [(\text{CH}_3)_3\text{C-Br}]$$

The rate is first order overall – unimolecular.

It appears that the nucleophile is not present in the R.D.S., but must react somewhere after the R.D.S. has occurred.

Mechanism:

Step 1: Formation of carbocation (R.D.S.)

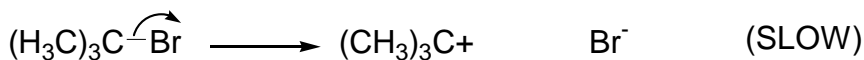

Step 2a: Nucleophilic Attack

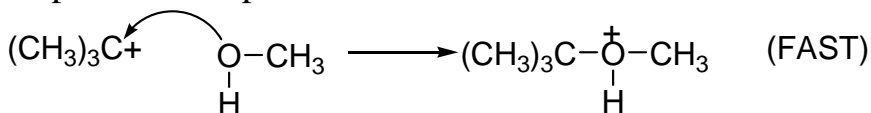

Step 2b: Loss of a proton

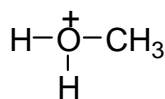
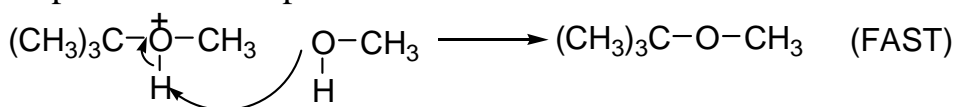

The  $\text{S}_{\text{N}}1$  reaction is a two step process, with the first being a slow ionization reaction generating a carbocation.

The second is the quick nucleophilic attack by the nucleophile on the carbocation. (In some case, like when water or alcohol is the nucleophile, a quick loss of a proton gives the final product).

In general:

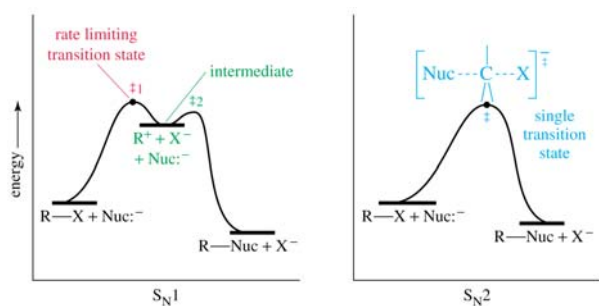

The  $S_N1$  reaction has two transition states, whereas the  $S_N2$  only has one transition state.

### Substituent Effects

The ionization to form the carbocation in the R.D.S is an endothermic process (breaking bonds), therefore the Hammond postulate tells us that the T.S. for this process should resemble the carbocation.

Consequently,  $S_N1$  rates depend on carbocation stability.

Since alkyl groups are known to stabilize carbocations (inductive effects and hyperconjugation),  $S_N1$  reactivities decrease in the order of:

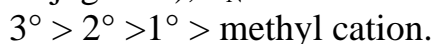

(This is the opposite for  $S_N2$  reactivity).

Resonance stabilized cation are also important for  $S_N1$  reactivity, for example, allyl bromide is much more reactive than other primary halides in  $S_N1$  reactions.

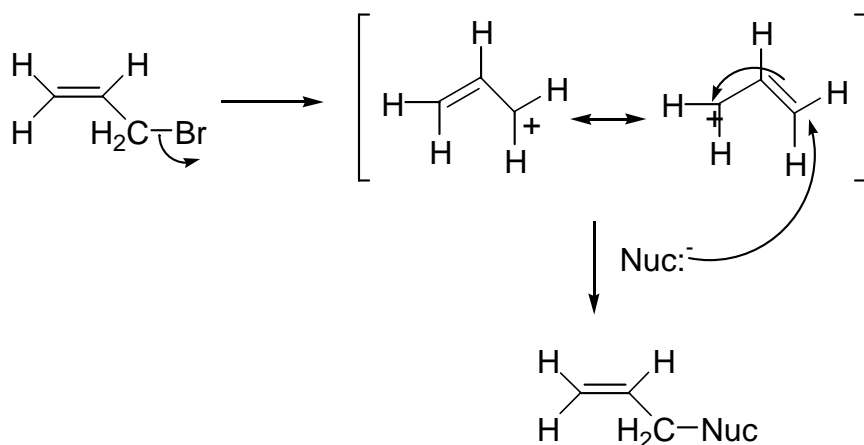

### Leaving Group Effects

In the R.D.S. for an  $S_N1$  reaction, the bond to the leaving group is breaking, therefore a highly polarizable leaving group helps stabilize the T.S. through partial bonding as it leaves (like for  $S_N2$  case).

The leaving group should be stable after it has left with the bonding electrons, and also be a weak base.



The leaving group starts to take on partial negative charge as the cation starts to form. Good leaving groups are essential for both  $S_N1$  and  $S_N2$  reactions.

### Solvent Effects

The R.D.S. of an  $S_N1$  reaction involves the formation of 2 ions, therefore polar solvents (which stabilize ions) enhance  $S_N1$  reactivities.

Protic solvents are especially useful since the hydrogen bonding stabilizes the anionic leaving group after ionization.

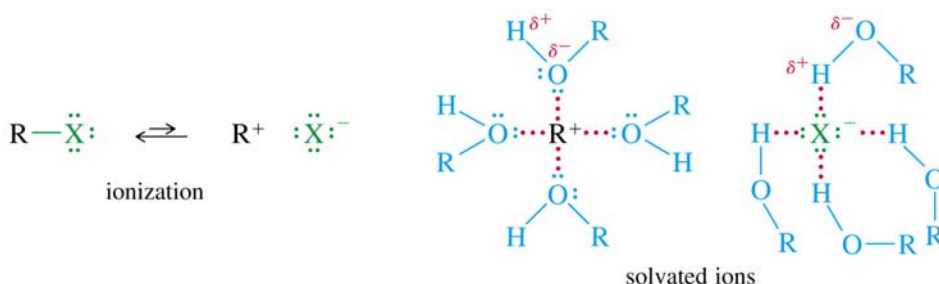

### Dielectric Constant

Dielectric constant ( $\epsilon$ ) is a measure of a solvents' polarity.

<u>Solvent</u>	$\epsilon$	<u>Rel. Rate</u>
Water	78	8000
Methanol	33	1000
Ethanol	24	200
Acetone	21	1
Diethyl ether	4.3	0.001
Hexane	2.0	< 0.0001

Ionization requires the stabilization of both positive and negative charges, solvents with higher  $\epsilon$  have faster rates for  $S_N1$  reactions.

## Stereochemistry of the S<sub>N</sub>1 Reaction

(Recall that the S<sub>N</sub>2 reaction is stereospecific, always proceeding with inversion).

The S<sub>N</sub>1 reaction is not stereospecific.

Consider the reaction below:

The carbocation produced is planar and sp<sup>2</sup> hybridized.

The nucleophile may attack from either the top or both face (typically it will do both).

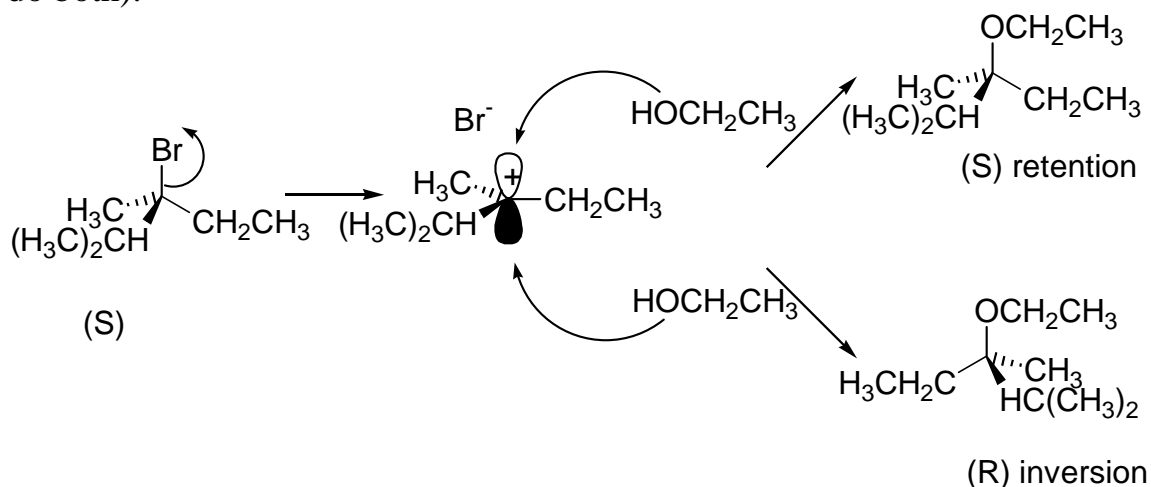

If the nucleophile attacks from the side that the leaving group was originally attached, the product displays retention of configuration.

If the nucleophile attacks from what would have been the back side of the leaving group, then the product displays an inversion of configuration.

A combination of inversion and retention is called racemization.

Often complete racemization is not achieved since the leaving group will partially block one face of the molecule as it ionizes, thus giving a **major** product of inversion.

## Rearrangements in S<sub>N</sub>1 Reactions

Carbocations will often undergo **rearrangements**, producing more stable ions.

For example the products of the S<sub>N</sub>1 reaction of 2-bromo-3-methylbutane and ethanol are a mixture of structural isomers – the expected product and a rearranged product.

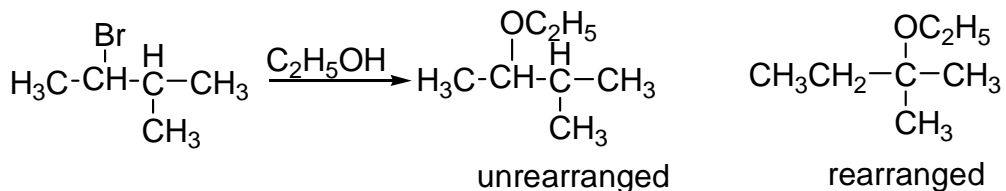

The two products arise from the same carbocation. In one case the cation is trapped by the nucleophile before it can rearrange, whereas the second product arises by quenching of the **rearranged** cation by the nucleophile.

### Mechanism

Step 1: Formation of carbocation

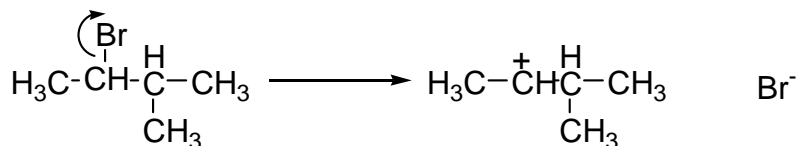

Step 2: Attack of solvent before and after rearrangement.

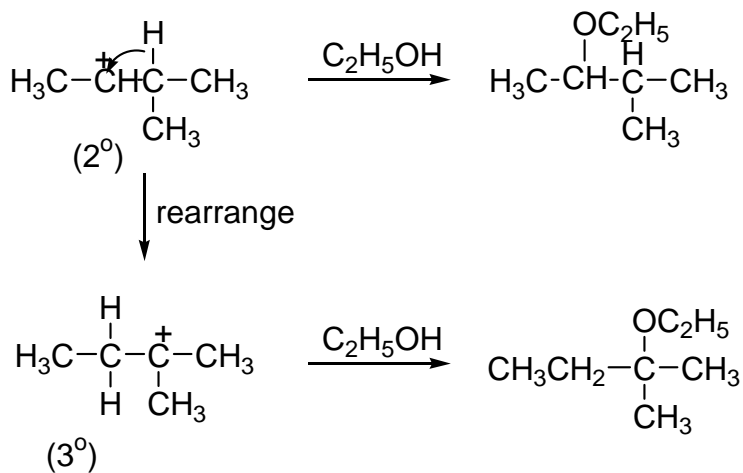

### Another Rearrangement

Neopentylbromide gives exclusively a rearranged product, which results from a methyl shift.

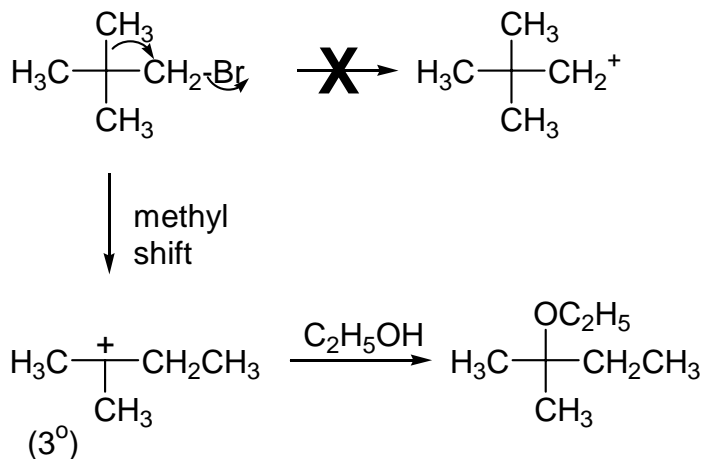

This rearrangement produces a tertiary cation (stable) instead of a primary cation (unstable).

In the cationic rearrangements, the moving group (**H and CH<sub>3</sub>**) take their bonding electrons with them (H<sup>-</sup> and CH<sub>3</sub><sup>-</sup>).

**Rearrangements occur when a more a stable cation can be produced by a hydrogen or alkyl group shift.**

(Rearrangements do not occur in S<sub>N</sub>2 reactions since carbocations are not intermediates).

## Recap of S<sub>N</sub>1 and S<sub>N</sub>2

### S<sub>N</sub>1

Nuc strength is unimportant

3° > 2° (1° / CH<sub>3</sub>X don't go)

Good ionizing solvent required

Rate = k<sub>r</sub>[R-X]

Racemization (inversion/retention)

Possible rearrangements

### S<sub>N</sub>2

Strong nucleophiles required

CH<sub>3</sub>X > 1° > 2° > 3°

May go faster in less polar solvent

rate = k<sub>r</sub>[R-X] [Nuc<sup>-</sup>]

Complete inversion

No rearrangements

## Eliminations

An elimination is the loss of two atoms or groups from a molecule, which will typically result in the formation of a new  $\pi$  bond.

For example the loss of H-Br to generate alkenes.

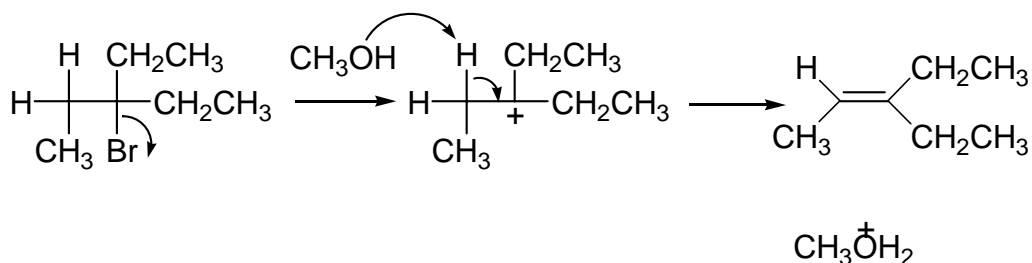

Bromide can be lost first, and then a proton removed to convert the carbocation into an alkene. (First order elimination: E1).

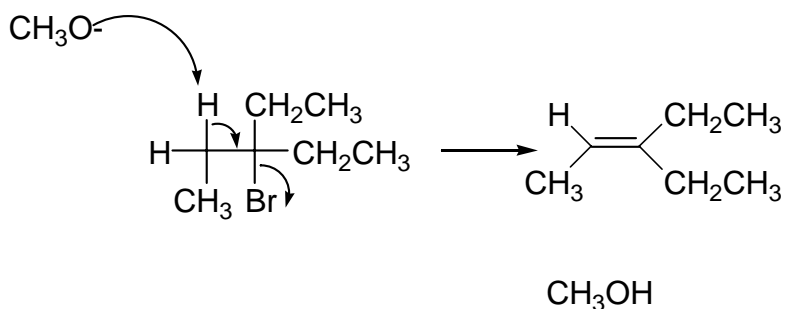

Alternatively, the bromide and the proton can be lost synchronously. (Second order elimination: E2).

### E1 Elimination

This is elimination, unimolecular.

Unimolecular means the R.D.S. involves one molecule. Again it is the slow ionization to generate a carbocation.

The second step is the fast removal of a proton by the solvent.

The electrons that were used for the C-H bond (which is broken) go to form the new C=C  $\pi$  bond.

In general for an E1:

Step 1: carbocation formation (slow, rate determining)

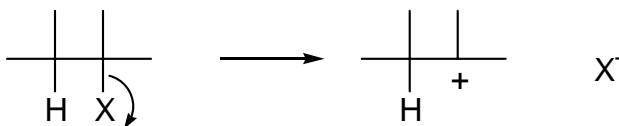

Step 2: abstraction of a proton (fast)

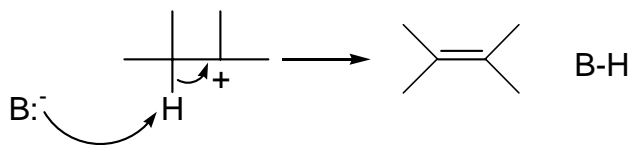

### Competition of E1 with S<sub>N</sub>1

Often when the carbocation is formed, S<sub>N</sub>1 and E1 processes compete with each other, and mixtures of elimination and substitution products occur.

For example the reaction of t-butylbromide and ethanol:

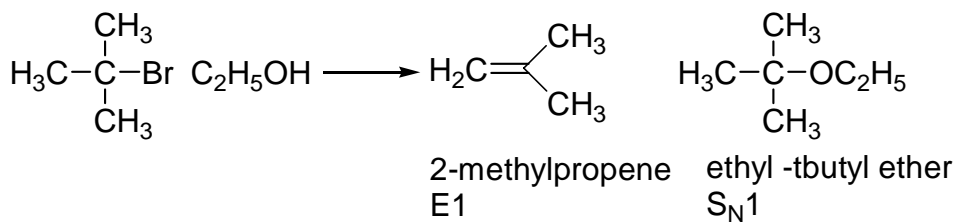

The unsaturated product arises from E1 elimination, and the ether comes from S<sub>N</sub>1 substitution.

### Energy diagram

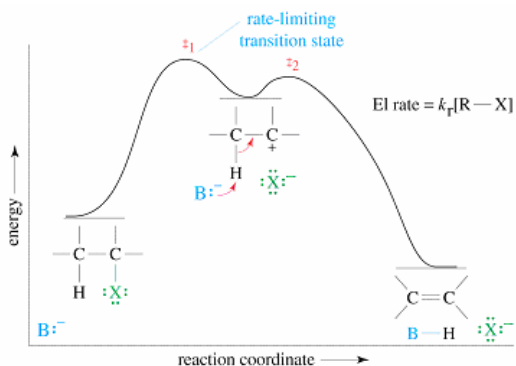

The E1 reaction has a large endothermic ionization, and this is the rate determining transition state.

The second step is a fast exothermic removal of a proton. The base does not figure in this reaction until after the R.D.S. and therefore does not appear in the rate equation.

### Cation Summary

Cations can react in 4 different fashions:

- (1) React with the leaving group to return to the starting material
- (2) React with a nucleophile to give a substitution product
- (3) Lose a proton to give an elimination product
- (4) Rearrange to give a more stable cation, and then react further.

### Second Order Elimination

It is possible to have a second order elimination.

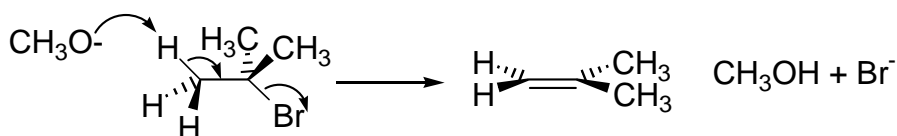

Generally this occurs with a **strong base**, which eliminates a proton quicker than the substrate can ionize.

**Normally the  $\text{S}_{\text{N}}2$  reaction does not compete with E2 since there is steric crowding around the C-X bond which retards the  $\text{S}_{\text{N}}2$  process.**

The rate is related to the concentrations of the substrate and the base, giving a **second order rate equation**. **E2 is elimination, bimolecular.**

The methoxide ion is acting as a base rather than a nucleophile.

The reaction takes place in one concerted step, with the C-H and C-X bonds breaking as the B-H and C-C bonds are forming.





Typically, concerted mechanisms require suitable geometries so that the orbitals of the atoms involved in the bond breaking and formation can overlap just right, so that electrons can smoothly flow from one bond to another.

The  $S_N2$  reaction requires back side attack.

The E2 reaction requires a coplanar arrangement of orbitals.

The partial  $\pi$  bond in the T.S. requires the parallel alignment of two p orbitals.

The electrons that were once the C-H bond must start to overlap with the orbital that the leaving group is vacating.

The two  $sp^3$  orbitals involved must be arranged parallel to achieve this overlap.

Two different arrangements satisfy these requirements, although one is preferred over the other.

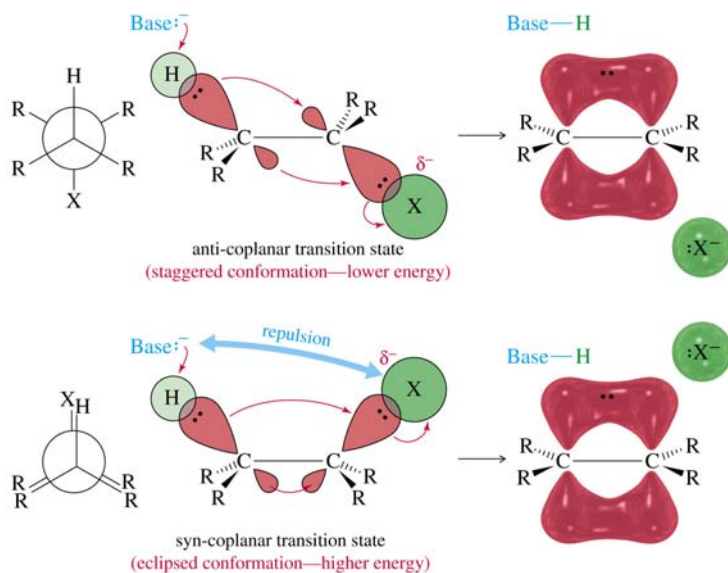

When the hydrogen and leaving group are anti to each other ( $\theta = 180^\circ$ ), this is called the anti-coplanar conformation.

When  $\theta=0^\circ$ , the hydrogen and leaving group eclipse each other, and this is the syn-coplanar conformation.

The anti-coplanar is of lower energy and is by far the most common.

In the anti-coplanar conformation the base and leaving group are well separated, thus removing electron repulsions.

The syn-coplanar conformation requires the base to approach much closer to the leaving group which is energetically unfavorable.

Certain molecules which are held in a fixed eclipsed type conformation may undergo syn-coplanar eliminations.

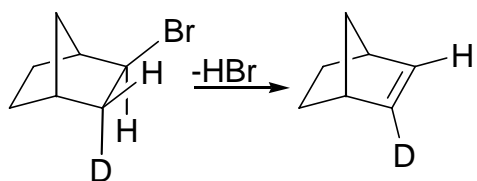

These are exceptions rather than the rule.

### E2 Eliminations using Diastereomers

The E2 reaction is a stereospecific reaction. A particular stereoisomer reacts to give one specific stereoisomer.

It is stereospecific since it prefers the anti-coplanar T.S. for elimination.

Consider the following two diastereomers:

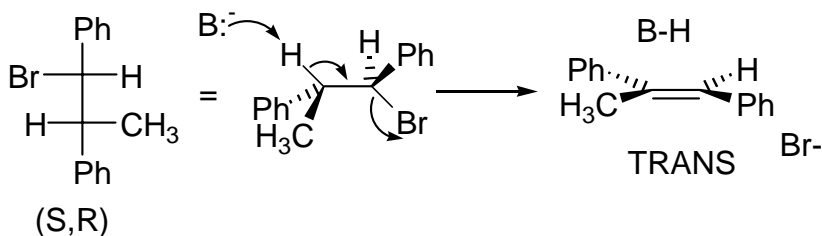

The (S,R) diastereomer gives a trans alkene.

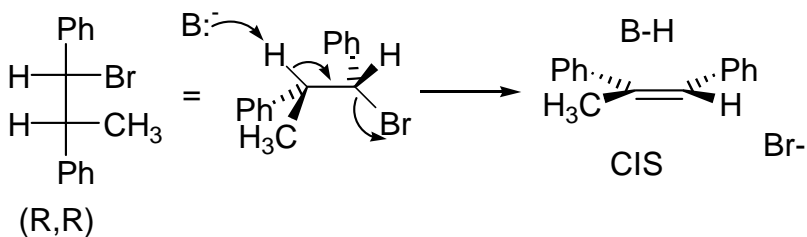

The (R,R) diastereomer gives a cis alkene.

The E2 is stereospecific.

### Dehalogenation

It is possible to generate alkenes from vicinal dibromides by reaction with iodide ion via an E2 process.

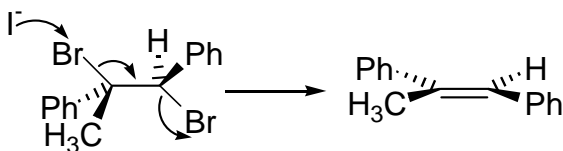

Again this reaction prefers the anti-coplanar arrangement.

It is a dehalogenation ( $-X_2$ ), not a dehydrohalogenation ( $-HX$ ).

### E2 Reactions in Cyclohexane Systems

Almost all cyclohexane systems are most stable in the chair conformations.

In a chair, adjacent axial positions are in an anti-coplanar arrangement, ideal for E2 eliminations.

Adjacent axial positions are said to be in a trans-diaxial arrangement.

E2's only proceed in chair conformations from trans-diaxial positions, and chair-chair interconversions allow the hydrogen and leaving group to attain the trans-diaxial arrangement.

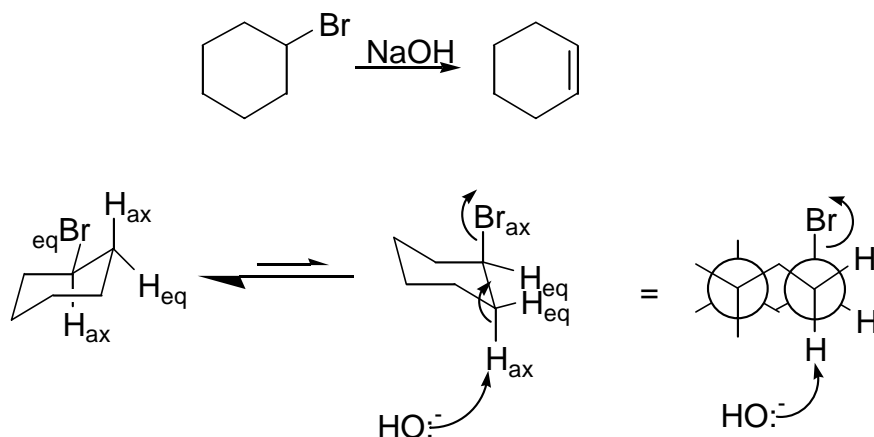

The elimination of HBr from bromocyclohexane gives cyclohexene.

The bromine must be in an axial position before it can leave.

### Comparison of E1 and E2

#### E1

Base strength unimportant

Good ionizing solvent required

Rate =  $k_r[\text{R-X}]$

Saytzeff Orientation

No special geometry required

Rearrangements are common

#### E2

Strong bases are required

Solvent polarity no so important

Rate =  $k_r[\text{R-X}][\text{B}^-]$

Saytzeff Orientation

Coplanarity required (anti >> syn)

No rearrangements

## Substitution versus Elimination Guidelines

- (a) The strength of a base or nucleophile will dictate the order of a reaction. (Strong bases/nucleophiles will react more quickly and create 2<sup>nd</sup> order kinetics).
- (b) Primary halides usually undergo S<sub>N</sub>2 with good nucleophiles. Also watch for rearrangements to more stable cations if ionization is possible.
- (c) Tertiary halides usually do not undergo S<sub>N</sub>2 reactions. More likely to undergo E2 with a good base, or E1 and S<sub>N</sub>1 otherwise.
- (d) Secondary halides can react in all ways (hard to predict).
- (e) High temperatures favor elimination.
- (f) The nucleophile/base will usually favor one or the other type of reaction. (t-butoxide favors elimination, bromide and iodide favor substitution).