

Young | Munson | Okiishi | Huebsch



*A Brief Introduction to*

# FLUID MECHANICS

| 4th Edition |

SECOND EDITION IN SI UNITS

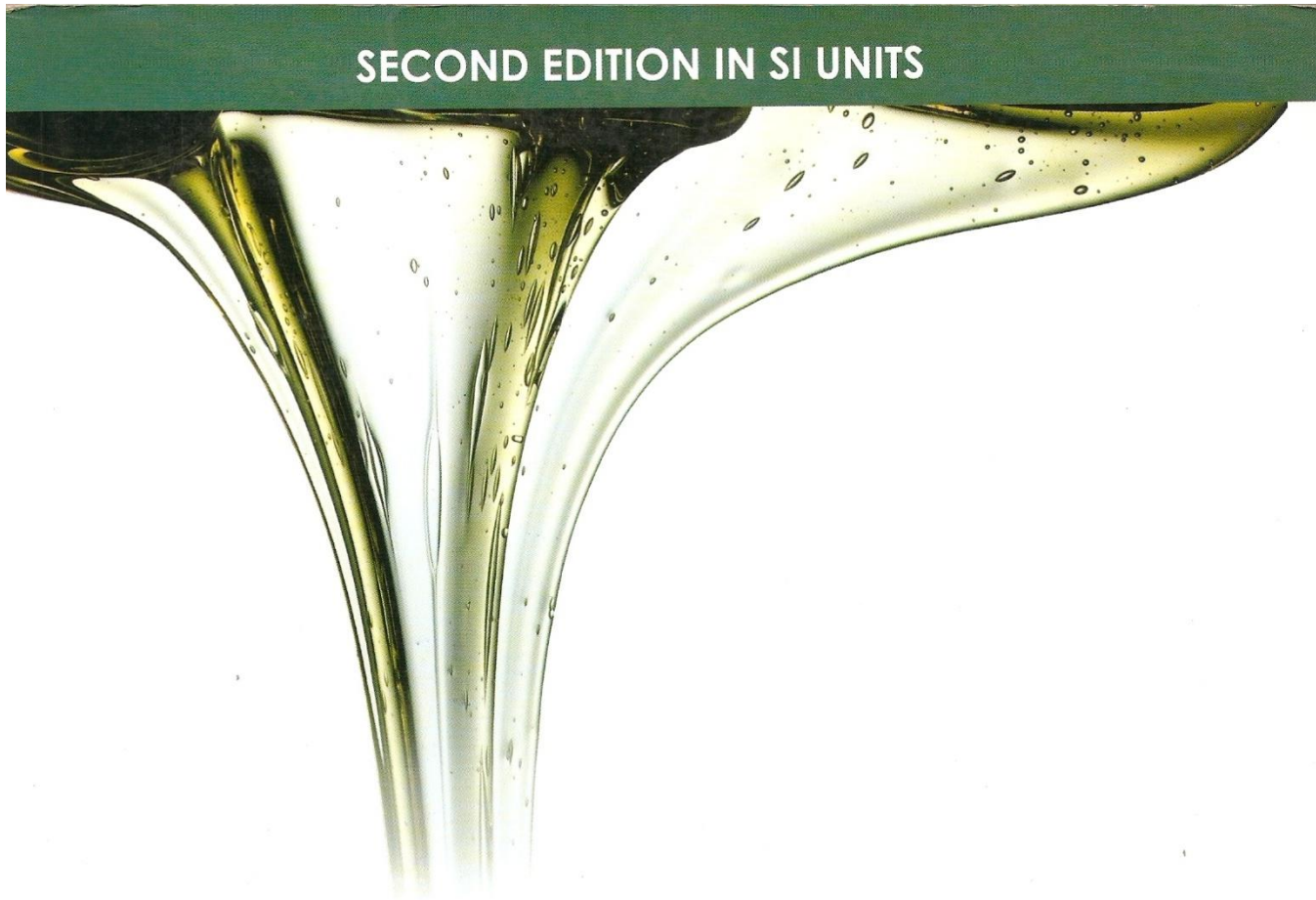

# Fluid Mechanics

## Fundamentals and Applications

Yunus A. Çengel  
John M. Cimbala

# FLUID FLOW

..... *for* .....

# CHEMICAL ENGINEERS

2<sup>ND</sup> EDITION

**F.A. HOLLAND & R. BRAGG**

Edward Arnold

# FLUID MECHANICS

Victor L. Streeter  
E. Benjamin Wylie

Seventh Edition



INTERNATIONAL  
STUDENT  
EDITION

Conversion Factors

DIMENSION	METRIC	METRIC/ENGLISH
Acceleration	1 m/s <sup>2</sup> = 100 cm/s <sup>2</sup>	1 m/s <sup>2</sup> = 3.2808 ft/s <sup>2</sup> 1 ft/s <sup>2</sup> = 0.3048* m/s <sup>2</sup>
Area	1 m <sup>2</sup> = 10 <sup>4</sup> cm <sup>2</sup> = 10 <sup>6</sup> mm <sup>2</sup> = 10 <sup>-6</sup> km <sup>2</sup>	1 m <sup>2</sup> = 1550 in <sup>2</sup> = 10.764 ft <sup>2</sup> 1 ft <sup>2</sup> = 144 in <sup>2</sup> = 0.09290304* m <sup>2</sup>
Density	1 g/cm <sup>3</sup> = 1 kg/L = 1000 kg/m <sup>3</sup>	1 g/cm <sup>3</sup> = 62.428 lbm/ft <sup>3</sup> = 0.036127 lbm/in <sup>3</sup> 1 lbm/in <sup>3</sup> = 1728 lbm/ft <sup>3</sup> 1 kg/m <sup>3</sup> = 0.062428 lbm/ft <sup>3</sup>
Energy, heat, work, and specific energy	1 kJ = 1000 J = 1000 N · m = 1 kPa · m <sup>3</sup> 1 kJ/kg = 1000 m <sup>2</sup> /s <sup>2</sup> 1 kWh = 3600 kJ	1 kJ = 0.94782 Btu 1 Btu = 1.055056 kJ = 5.40395 psia · ft <sup>3</sup> = 778.169 lbf · ft 1 Btu/lbm = 25,037 ft <sup>2</sup> /s <sup>2</sup> = 2.326* kJ/kg 1 kWh = 3412.14 Btu
Force	1 N = 1 kg · m/s <sup>2</sup> = 10 <sup>5</sup> dyne 1 kgf = 9.80665 N	1 N = 0.22481 lbf 1 lbf = 32.174 lbm · ft/s <sup>2</sup> = 4.44822 N 1 lbf = 1 slug · ft/s <sup>2</sup>
Length	1 m = 100 cm = 1000 mm = 10 <sup>6</sup> μm 1 km = 1000 m	1 m = 39.370 in = 3.2808 ft = 1.0926 yd 1 ft = 12 in = 0.3048* m 1 mile = 5280 ft = 1.6093 km 1 in = 2.54* cm
Mass	1 kg = 1000 g 1 metric ton = 1000 kg	1 kg = 2.2046226 lbm 1 lbm = 0.45359237* kg 1 ounce = 28.3495 g 1 slug = 32.174 lbm = 14.5939 kg 1 short ton = 2000 lbm = 907.1847 kg
Power	1 W = 1 J/s 1 kW = 1000 W = 1 kJ/s 1 hp <sup>‡</sup> = 745.7 W	1 kW = 3412.14 Btu/h = 1.341 hp = 737.56 lbf · ft/s 1 hp = 550 lbf · ft/s = 0.7068 Btu/s = 42.41 Btu/min = 2544.5 Btu/h = 0.74570 kW 1 Btu/h = 1.055056 kJ/h
Pressure or stress, and pressure expressed as a head	1 Pa = 1 N/m <sup>2</sup> 1 kPa = 10 <sup>3</sup> Pa = 10 <sup>-3</sup> MPa 1 atm = 101.325 kPa = 1.01325 bar = 760 mm Hg at 0°C = 1.03323 kgf/cm <sup>2</sup> 1 mm Hg = 0.1333 kPa	1 Pa = 1.4504 × 10 <sup>-4</sup> psi = 0.020886 lbf/ft <sup>2</sup> 1 psi = 144 lbf/ft <sup>2</sup> = 6.894757 kPa 1 atm = 14.696 psi = 29.92 inches Hg at 30°F 1 inch Hg = 13.60 inches H <sub>2</sub> O = 3.387 kPa
Specific heat	1 kJ/kg · °C = 1 kJ/kg · K = 1 J/g · °C	1 Btu/lbm · °F = 4.1868 kJ/kg · °C 1 Btu/lbmol · R = 4.1868 kJ/kmol · K 1 kJ/kg · °C = 0.23885 Btu/lbm · °F = 0.23885 Btu/lbm · R
Specific volume	1 m <sup>3</sup> /kg = 1000 L/kg = 1000 cm <sup>3</sup> /g	1 m <sup>3</sup> /kg = 16.02 ft <sup>3</sup> /lbm 1 ft <sup>3</sup> /lbm = 0.062428 m <sup>3</sup> /kg
Temperature	T(K) = T(°C) + 273.15 ΔT(K) = ΔT(°C)	T(R) = T(°F) + 459.67 = 1.8T(K) T(°F) = 1.8 T(°C) + 32 ΔT(°F) = ΔT(R) = 1.8* ΔT(K)
Velocity	1 m/s = 3.60 km/h	1 m/s = 3.2808 ft/s = 2.237 mi/h 1 mi/h = 1.46667 ft/s 1 mi/h = 1.6093 km/h
Viscosity, dynamic	1 kg/m · s = 1 N · s/m <sup>2</sup> = 1 Pa · s = 10 poise	1 kg/m · s = 2419.1 lbm/ft · h = 0.020886 lbf · s/ft <sup>2</sup> = 0.67197 lbm/ft · s

\*Exact conversion factor between metric and English units.

‡Mechanical horsepower. The electrical horsepower is taken to be exactly 746 W. -

DIMENSION	METRIC	METRIC/ENGLISH
Viscosity, kinematic	1 m <sup>2</sup> /s = 10 <sup>4</sup> cm <sup>2</sup> /s 1 stoke = 1 cm <sup>2</sup> /s = 10 <sup>-4</sup> m <sup>2</sup> /s	1 m <sup>2</sup> /s = 10.764 ft <sup>2</sup> /s = 3.875 × 10 <sup>4</sup> ft <sup>2</sup> /h 1 m <sup>2</sup> /s = 10.764 ft <sup>2</sup> /s
Volume	1 m <sup>3</sup> = 1000 L = 10 <sup>6</sup> cm <sup>3</sup> (cc)	1 m <sup>3</sup> = 6.1024 × 10 <sup>4</sup> in <sup>3</sup> = 35.315 ft <sup>3</sup> = 264.17 gal (U.S.) 1 U.S. gallon = 231 in <sup>3</sup> = 3.7854 L 1 fl ounce = 29.5735 cm <sup>3</sup> = 0.0295735 L 1 U.S. gallon = 128 fl ounces
Volume flow rate	1 m <sup>3</sup> /s = 60,000 L/min = 10 <sup>6</sup> cm <sup>3</sup> /s	1 m <sup>3</sup> /s = 15,850 gal/min = 35.315 ft <sup>3</sup> /s = 2118.9 ft <sup>3</sup> /min (CFM)

\*Exact conversion factor between metric and English units.

#### Some Physical Constants

PHYSICAL CONSTANT	METRIC	ENGLISH
Standard acceleration of gravity	$g = 9.80665 \text{ m/s}^2$	$g = 32.174 \text{ ft/s}^2$
Standard atmospheric pressure	$P_{\text{atm}} = 1 \text{ atm} = 101.325 \text{ kPa}$ = 1.01325 bar = 760 mm Hg (0°C) = 10.3323 m H <sub>2</sub> O (4°C)	$P_{\text{atm}} = 1 \text{ atm} = 14.696 \text{ psia}$ = 2116.2 lbf/ft <sup>2</sup> = 29.9213 inches Hg (32°F) = 406.78 inches H <sub>2</sub> O (39.2°F)
Universal gas constant	$R_u = 8.31447 \text{ kJ/kmol} \cdot \text{K}$ = 8.31447 kN · m/kmol · K	$R_u = 1.9859 \text{ Btu/lbmol} \cdot \text{R}$ = 1545.37 ft · lbf/lbmol · R

#### Commonly Used Properties

PROPERTY	METRIC	ENGLISH
<i>Air at 20°C (68°F) and 1 atm</i>		
Specific gas constant*	$R_{\text{air}} = 0.2870 \text{ kJ/kg} \cdot \text{K}$ = 287.0 m <sup>2</sup> /s <sup>2</sup> · K	$R_{\text{air}} = 0.06855 \text{ Btu/lbm} \cdot \text{R}$ = 53.34 ft · lbf/lbm · R = 1716 ft <sup>2</sup> /s <sup>2</sup> · R
Specific heat ratio	$k = c_p/c_v = 1.40$	$k = c_p/c_v = 1.40$
Specific heats	$c_p = 1.007 \text{ kJ/kg} \cdot \text{K}$ = 1007 m <sup>2</sup> /s <sup>2</sup> · K $c_v = 0.7200 \text{ kJ/kg} \cdot \text{K}$ = 720.0 m <sup>2</sup> /s <sup>2</sup> · K	$c_p = 0.2404 \text{ Btu/lbm} \cdot \text{R}$ = 187.1 ft · lbf/lbm · R = 6019 ft <sup>2</sup> /s <sup>2</sup> · R $c_v = 0.1719 \text{ Btu/lbm} \cdot \text{R}$ = 133.8 ft · lbf/lbm · R = 4304 ft <sup>2</sup> /s <sup>2</sup> · R
Speed of sound	$c = 343.2 \text{ m/s} = 1236 \text{ km/h}$	$c = 1126 \text{ ft/s} = 767.7 \text{ mi/h}$
Density	$\rho = 1.204 \text{ kg/m}^3$	$\rho = 0.07518 \text{ lbm/ft}^3$
Viscosity	$\mu = 1.825 \times 10^{-5} \text{ kg/m} \cdot \text{s}$	$\mu = 1.227 \times 10^{-5} \text{ lbm/ft} \cdot \text{s}$
Kinematic viscosity	$\nu = 1.516 \times 10^{-5} \text{ m}^2/\text{s}$	$\nu = 1.632 \times 10^{-4} \text{ ft}^2/\text{s}$
<i>Liquid water at 20°C (68°F) and 1 atm</i>		
Specific heat ( $c = c_p = c_v$ )	$c = 4.182 \text{ kJ/kg} \cdot \text{K}$ = 4182 m <sup>2</sup> /s <sup>2</sup> · K	$c = 0.9989 \text{ Btu/lbm} \cdot \text{R}$ = 777.3 ft · lbf/lbm · R = 25,009 ft <sup>2</sup> /s <sup>2</sup> · R
Density	$\rho = 998.0 \text{ kg/m}^3$	$\rho = 62.30 \text{ lbm/ft}^3$
Viscosity	$\mu = 1.002 \times 10^{-3} \text{ kg/m} \cdot \text{s}$	$\mu = 6.733 \times 10^{-4} \text{ lbm/ft} \cdot \text{s}$
Kinematic viscosity	$\nu = 1.004 \times 10^{-6} \text{ m}^2/\text{s}$	$\nu = 1.081 \times 10^{-5} \text{ ft}^2/\text{s}$

■ **TABLE 1.4**  
Approximate Physical Properties of Some Common Liquids (BG Units)

Liquid	Temperature (°F)	Density, $\rho$ (slugs/ft <sup>3</sup> )	Specific Weight, $\gamma$ (lb/ft <sup>3</sup> )	Dynamic Viscosity, $\mu$ (lb·s/ft <sup>2</sup> )	Kinematic Viscosity, $\nu$ (ft <sup>2</sup> /s)	Surface Tension, <sup>a</sup> $\sigma$ (lb/ft)	Vapor Pressure, $P_v$ [lb/in. <sup>2</sup> (abs)]	Bulk Modulus, <sup>b</sup> $E_v$ (lb/in. <sup>2</sup> )
Carbon tetrachloride	68	3.09	99.5	2.00 E - 5	6.47 E - 6	1.84 E - 3	1.9 E + 0	1.91 E + 5
Ethyl alcohol	68	1.53	49.3	2.49 E - 5	1.63 E - 5	1.56 E - 3	8.5 E - 1	1.54 E + 5
Gasoline <sup>c</sup>	60	1.32	42.5	6.5 E - 6	4.9 E - 6	1.5 E - 3	8.0 E + 0	1.9 E + 5
Glycerin	68	2.44	78.6	3.13 E - 2	1.28 E - 2	4.34 E - 3	2.0 E - 6	6.56 E + 5
Mercury	68	26.3	847	3.28 E - 5	1.25 E - 6	3.19 E - 2	2.3 E - 5	4.14 E + 6
SAE 30 oil <sup>c</sup>	60	1.77	57.0	8.0 E - 3	4.5 E - 3	2.5 E - 3	—	2.2 E + 5
Seawater	60	1.99	64.0	2.51 E - 5	1.26 E - 5	5.03 E - 3	2.26 E - 1	3.39 E + 5
Water	60	1.94	62.4	2.34 E - 5	1.21 E - 5	5.03 E - 3	2.26 E - 1	3.12 E + 5

<sup>a</sup>In contact with air.

<sup>b</sup>Isentropic bulk modulus calculated from speed of sound.

<sup>c</sup>Typical values. Properties of petroleum products vary.

■ **TABLE 1.5**  
Approximate Physical Properties of Some Common Liquids (SI Units)

Liquid	Temperature (°C)	Density, $\rho$ (kg/m <sup>3</sup> )	Specific Weight, $\gamma$ (kN/m <sup>3</sup> )	Dynamic Viscosity, $\mu$ (N·s/m <sup>2</sup> )	Kinematic Viscosity, $\nu$ (m <sup>2</sup> /s)	Surface Tension, <sup>a</sup> $\sigma$ (N/m)	Vapor Pressure, $P_v$ [N/m <sup>2</sup> (abs)]	Bulk Modulus, <sup>b</sup> $E_v$ (N/m <sup>2</sup> )
Carbon tetrachloride	20	1,590	15.6	9.58 E - 4	6.03 E - 7	2.69 E - 2	1.3 E + 4	1.31 E + 9
Ethyl alcohol	20	789	7.74	1.19 E - 3	1.51 E - 6	2.28 E - 2	5.9 E + 3	1.06 E + 9
Gasoline <sup>c</sup>	15.6	680	6.67	3.1 E - 4	4.6 E - 7	2.2 E - 2	5.5 E + 4	1.3 E + 9
Glycerin	20	1,260	12.4	1.50 E + 0	1.19 E - 3	6.33 E - 2	1.4 E - 2	4.52 E + 9
Mercury	20	13,600	133	1.57 E - 3	1.15 E - 7	4.66 E - 1	1.6 E - 1	2.85 E + 10
SAE 30 oil <sup>c</sup>	15.6	912	8.95	3.8 E - 1	4.2 E - 4	3.6 E - 2	—	1.5 E + 9
Seawater	15.6	1,030	10.1	1.20 E - 3	1.17 E - 6	7.34 E - 2	1.77 E + 3	2.34 E + 9
Water	15.6	999	9.80	1.12 E - 3	1.12 E - 6	7.34 E - 2	1.77 E + 3	2.15 E + 9

<sup>a</sup>In contact with air.

<sup>b</sup>Isentropic bulk modulus calculated from speed of sound.

<sup>c</sup>Typical values. Properties of petroleum products vary.

# Chapter 1

## 1-1. Introduction

**Mechanics** is the **oldest physical science** that deals with both **stationary** and **moving bodies** under the influence of forces. The branch of mechanics that deals with bodies at **rest** is called **statics**, while the branch that deals with bodies in **motion** is called **dynamics**. The subcategory **fluid mechanics** is defined as the science that deals the behavior of fluids at rest (**fluid statics**) or in motion (**fluid dynamics**), and interaction of fluids with solids or other fluids at boundaries. From the physics a **substance** exists in three primary phases: **solid**, **liquid**, and **gas**. At (very **high temperature**, it also exists as **plasma**). A substance in the liquid or gas phase is referred to as a **fluid**.

### 1- 1.1. **Fluid:**

Is defined as a substance that deforms continuously when acted on by a **shearing stress** of any magnitude. A shearing stress (**force per unit area**) is created whenever a **tangential force** acts on a surface. When common solids such as steel or other metals are acted on by shearing stress, they will be initially deform (usually a very small deformation), but they will not continuously deform (flow). However, common fluids such as water, oil, and air satisfy the definition of fluid- that is; they will flow when acted on by a shearing stress. Some materials, such as slurries, tar, putty, toothpaste, and so on, are not easy classified since they will behave as a solid if the applied shearing stress is small, but if the stress exceeds some critical value, the substance will flow.

### 1-1.2. **Fluid flow:**

Has numerous applications in many engineering and science disciplines such as: marine engineering, meteorology, biological sciences, aeronautical engineering, chemical, food, drugs, and petrochemical industries, and onshore and offshore fluid transportation engineering. The study of fluid flow is important to all engineering disciplines that must deal with the moving of fluids inside or around objects.



### 1-1.3. *Application Area of Fluid Mechanics:*

It is important to develop a good understanding of the basic principles of fluid mechanics, since fluid mechanics is widely used both in everyday activities and in the design of modern engineering systems from **vacuum cleaners** to **supersonic aircraft**. An ordinary house is, in some respects, an exhibition hall filled with applications of fluids mechanics. The piping systems for water, natural gas, and sewage for an individual house. On a broader scale, fluid mechanics plays a major part in the design and analysis of aircraft, boats, submarines, rockets, jet engines, wind turbines, etc..... Numerous natural phenomena such as the rain cycle, weather patterns, the rise of ground water to the tops of trees, winds, ocean waves, and currents in large water bodies are also governed by the principles of fluid mechanics (**Figure 1-1**).

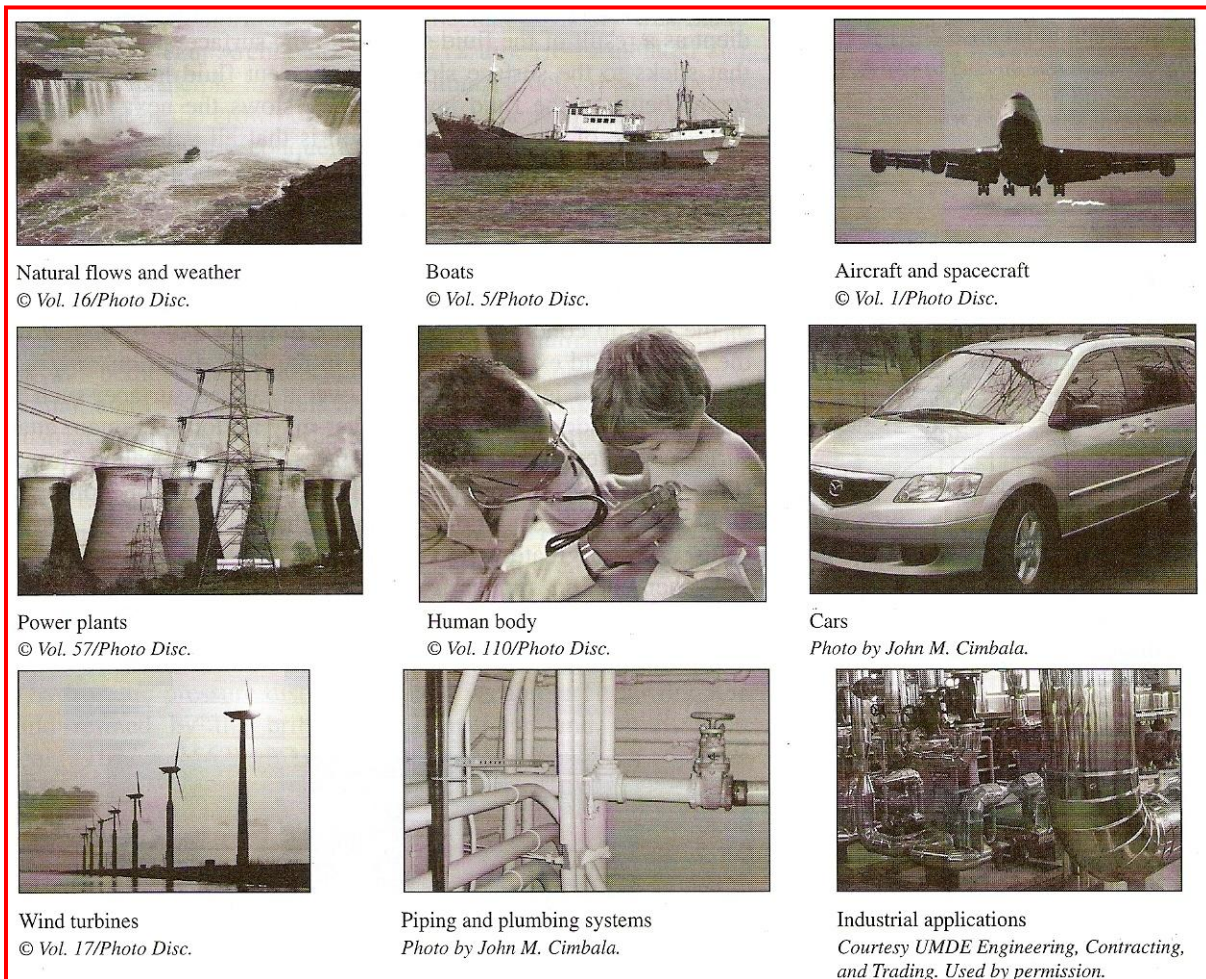

**Figure 1-1.** Some application areas of fluid mechanics.

## 1-2. Dimensions and Unites

Any **physical quantity** can be characterized by **dimensions**. The magnitudes assigned to the dimensions are called **units**. Some basic dimensions such as mass  $m$ , length  $L$ , time  $t$ , and temperature  $T$  are selected as **primary** or **fundamental dimensions**, while others such as velocity  $V$ , energy  $E$ , and volume  $V$  are expressed in terms of the **primary dimensions** and are called **secondary dimension**, or **derived dimensions**. In **1960**, the General Conference of Weights and Measures(CGPM) produce the **SI**, which was based on six fundamental quantities, their units were adopted in **1954** at the Tenth of CGPM: **meter** (m)for length , **kilogram** (kg), for mass, **second** (s) for time, **ampere** (A)for electrical current, **degree Kelvin** (K) for temperature, and **candela** (cd) for luminous intensity (amount of light), in **1971** , the CGPM added a seventh fundamental quantity and unit **mol** (mol) for amount of matter(**Table 1-1**).

**Table 1-1.**

The seven fundamental (or primary) dimensions and their units in SI	
Dimension	Unit
Length	meter (m)
Mass	kilogram (kg)
Time	second (s)
Temperature	kelvin (K)
Electric current	ampere (A)
Amount of light	candela (cd)
Amount of matter	mole (mol)

As pointed out, the SI is based on decimal relationship between units. The prefixes used to express the multiples of the various units are listed in **Table 1-2**. They are standard for all unites.

**Table 1-2.**

Standard prefixes in SI units	
Multiple	Prefix
$10^{24}$	yotta, Y
$10^{21}$	zetta, Z
$10^{18}$	exa, E
$10^{15}$	peta, P
$10^{12}$	tera, T
$10^9$	giga, G
$10^6$	mega, M
$10^3$	kilo, k
$10^2$	hecto, h
$10^1$	deka, da
$10^{-1}$	deci, d
$10^{-2}$	centi, c
$10^{-3}$	milli, m
$10^{-6}$	micro, $\mu$
$10^{-9}$	nano, n
$10^{-12}$	pico, p
$10^{-15}$	femto, f
$10^{-18}$	atto, a
$10^{-21}$	zepto, z
$10^{-24}$	yocto, y

### **1-2.1. System of Units:**

There are several system of units in use and we shall consider two systems that are commonly used in engineering:

**British Gravitational (BG) System.** In the BG system the unit of length is the foot (ft), the time unit is the second (s), the force unit is the pound (lb), and the temperature unit is the degree Fahrenheit ( $^{\circ}\text{F}$ ), or the absolute temperature unit is the degree Rankine (R), where

$$R = ^{\circ}\text{F} + 459.67$$

The mass unit, called the **slug**, is defined from Newton's second law (**force = mass x acceleration**) as:

$$1 \text{ lb} = (1 \text{ slug}) \times (1 \text{ ft/s}^2)$$

The relationship indicates that a **1 lb force** acting on a mass of **1 slug** will give the mass an acceleration of **1 ft/s<sup>2</sup>**.

The weight, **W** (which is the force due to gravity, **g**) of a mass, **m**, is given by the equation:

$$W = mg$$

And in **BG** units:

$$W (\text{lb}) = m (\text{slug}) g (\text{ft/s}^2)$$

Since the earth's standard gravity is taken as **g = 32.174 ft/s<sup>2</sup>** (commonly approximated as **32.2 ft/s<sup>2</sup>**), it follows that the mass of **1 slug** weight **32.2 lb** under standard gravity.

**International system (SI).** In SI the unit of **length** is the meter (**m**), the **time** unit is the second (**s**), the **mass** unit is the kilogram (**kg**), and the **temperature** unit is the Kelvin (**K**).the Kelvin temperature scale is an absolute and related to the Celsius (centigrade) scale ( $^{\circ}\text{C}$ ) through the relation:

$$K = ^{\circ}\text{C} + 273.15$$

Although the Celsius scale is not in itself part of **SI**, it is common practice to specify temperature in degree Celsius when using **SI** units.

The force unit, called the Newton (**N**), is defined from Newton's second law as:

$$1 \text{ N} = (1 \text{ kg}) (1 \text{ m/s}^2)$$

Thus, a **1 N force** acting on a **1 kg mass** will give the mass an **acceleration of 1 m/s<sup>2</sup>**. Standard gravity in **SI** is **9.807 m/s<sup>2</sup>** (commonly approximated as **9.81 m/s<sup>2</sup>**) so that a 1 kg mass weights 9.81 N under standard gravity. Note that weight and mass are different, both qualitatively and quantitatively.

The unit of work in **SI** is the joule (**J**), which is the work done when the point of application of a **1 N** force is displaced through a **1 m** distance in direction of the force. Thus,

$$1 \text{ J} = 1 \text{ N} \cdot \text{m}$$

The unit of power is the watt (**W**) defined as a joule per second. Thus,

$$1 \text{ W} = 1 \text{ J/s} = 1 \text{ N} \cdot \text{m/s}$$

### 1-3. measures of fluid mass, weight, and viscosity

#### 1-3.1. *Density:*

The **density** of the fluid, designated by Greek symbol  $\rho$  (rho), is defined as its mass per unit volume. Density is typically used to characterize the mass of fluid system. In **BG** system,  $\rho$  has units of **slugs/ft<sup>3</sup>** and in **SI** units are **kg/m<sup>3</sup>**. The value of density can vary widely between different fluids, but for liquids, variation in pressure and temperature generally have only a small effect on the value of  $\rho$ . The small changes in the density of water with large variation in temperature is variations in temperature is illustrated in **Figure 1-2**.

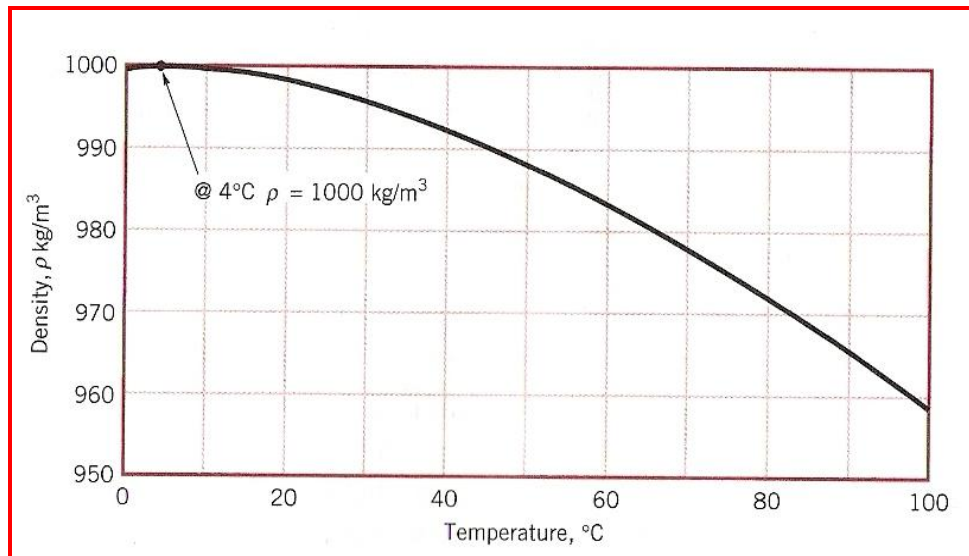

**Figure 1-2.** Density of water as a function of temperature.

The specific volume,  $v$ , is the volume per unit mass and is therefore the reciprocated o the density---that is:

$$v = \frac{1}{\rho} \quad (1.1)$$

The property is not commonly used in fluid mechanics, but is used in thermodynamics.

### 1-3.2. *specific weight:*

The *specific weight* of the fluid, designated by the Greek symbol  $\gamma$  (gamma), is defined as its *weight* per unit volume. Thus, specific weight related to *density* through the equation:

$$\gamma = \rho g \quad (1.2)$$

where  $g$  is the local acceleration of gravity. Just as density is used to characterize the *mass* of fluid system, the *specific weight* is used to characterize the *weight* of the system. In the **BG** system,  $\gamma$  has units of **lb/ft<sup>3</sup>** and in **SI** the units are **N/m<sup>3</sup>**. Under standard gravity ( $g = 32.174 \text{ ft/s}^2 = 9.807 \text{ m/s}^2$ ), water at **60 °F** has a specific weight of **62.4 lb/ft<sup>3</sup>** and **9.80 kN/m<sup>3</sup>**. **Table 1.4** and **1.5** list values of *specific weight* for several common liquid (based on standard).

### 1-3.3. *specific gravity:*

The *specific gravity* of a fluid, designated as **SG**, is defined as the ratio of the density of the fluid to the of water at some specified temperature. Usually the specified temperature is taken as **4 °C (39.2 °F)**, and at this temperature the *density of water* is **1.94 slugs/ft<sup>3</sup>** or **1000 kg/m<sup>3</sup>**. In equation form specific gravity is expressed as:

$$SG = \frac{\rho}{\rho_{H2O @ 4^\circ C}} \quad (1.3)$$

The value of **SG** does not depend on the system of units used. For **example**, the specific gravity of mercury at **20 °C** is **13.55**, and the density of mercury can thus be readily calculated in either **BG** or **SI** units through the use of **equation 1.3** as:

$$\rho_{Hg} = (13.55)(1.94 \text{ slugs/ft}^3) = 26.3 \text{ slugs/ft}^3$$

or

$$\rho_{Hg} = (13.55)(1000 \text{ kg/m}^3) = 13.6 \times 10^3 \text{ kg/m}^3$$

It is clear that **density**, **specific gravity**, and **specific weight** are all interrelated, and from knowledge of any one of three the others can be calculated.

#### 1-3.4. **Viscosity:**

For common fluids, such as water, oil, gasoline, and air, the shearing stress ( $\tau$ ) and rate of shearing strain (velocity gradient) can be related with a relationship of the form:

$$\tau = \mu \frac{du}{dy} \quad (1.4)$$

where the constant of proportionality is designed by the Greek symbol  $\mu$  (**mu**) and is called the **absolute viscosity**, **dynamic viscosity**, or simply the **viscosity** of the fluids.

In accordance with **Equation 1.4**, plot of  $\tau$  versus  $du/dy$  should be linear with the slope equal to the viscosity as illustrated in **Figure 1-3**.

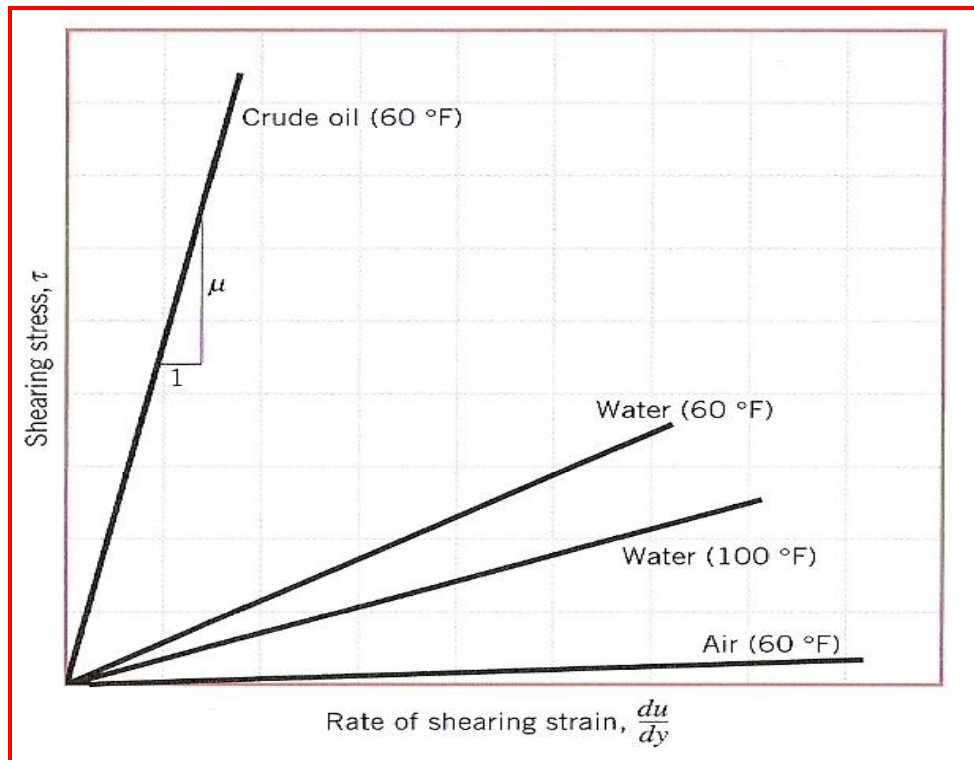

**Figure 1-3.** Linear variation of shearing stress with rate of shearing strain.

The actual value of the viscosity depends on particular fluid, for a particular fluid the viscosity is also highly dependent on temperature as illustrated in **Figure 1-3** with the two curves for water. Fluids for which the **shearing stress** is **linearly** related to the rate of **shearing strain** (also referred to as rate of angular deformation) are designated as **Newtonian fluids**. Fortunately, most common fluids, both liquids and gases, are **Newtonian**.

Fluids for which the **shearing stress** is not linearly related to the rate of **shearing strain** are designated as **non-Newtonian fluids**. The  $\mu$  in **BG** units are given as **lb.s/ft<sup>2</sup>** and in **SI** units as **N.s/m<sup>2</sup>**.

Quite often viscosity appears in the fluid flow problems combined with the density in the form:

$$\nu = \frac{\mu}{\rho}$$

This ratio is called the **kinematic viscosity** and is denoted with Greek symbol  $\nu$  (nu).  $\nu$  in **BG** units **ft<sup>2</sup>/s** and SI units are **m<sup>2</sup>/s**.

## 1-4. Types of flow in pipes

### 1-4.1. **Laminar and turbulent flow:**

If water is caused to flow steadily through a transparent tube and a dye is continuously injected into the water, **two distinct types** of flow may be **observed**: In the first type, shown schematically in **Figure 1-4 (a)**, the streaklines are straight and the dye remains intact. The dye is observed to spread very slightly as it is carried through the tube; this is due to molecular diffusion. The flow causes no mixing of the dye with the surrounding water. In this type of flow, known as **laminar** or **streamline** flow, elements of the fluid flow in an orderly fashion without any macroscopic intermixing with neighboring fluid. In this experiment, laminar flow is observed only at low flow rates. On increasing the flow rate, a markedly different type is established in which the dye streaks show a chaotic, fluctuating type of motion, known as **turbulent flow**, **Figure 1-4 (b)**. A characteristic of turbulent flow is that it promotes rapid mixing over a length scale comparable to the diameter of the tube. In both **laminar** and **turbulent** flow the **velocity** is **zero** at the **wall** and has a **maximum** value at



the **center-line**. For **laminar** flow the velocity profile is a **parabola** but for **turbulent** flow the profile is **much flatter** over most of the diameter.

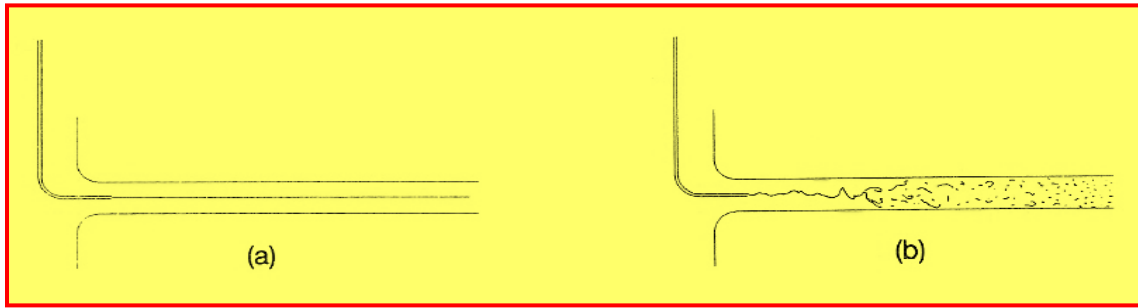

**Figure 1-4.** Flow regimes in a pipe shown by eye (a) **laminar** (b) **turbulent**.

If the pressure drop across the length of the tube were measured in these experiments it would be found that the **pressure drop** is **proportional** to the **flow rate** when the flow is **laminar**. However, as shown in **Figure 1-3**, when the flow is turbulent the **pressure drop** increases **more rapidly**, almost as the **square** of the **flow rate**. The turbulent flow has the advantage of promoting rapid mixing and enhances convective heat and mass transfer. The penalty that has to be paid for this greater power required to pump the fluid.

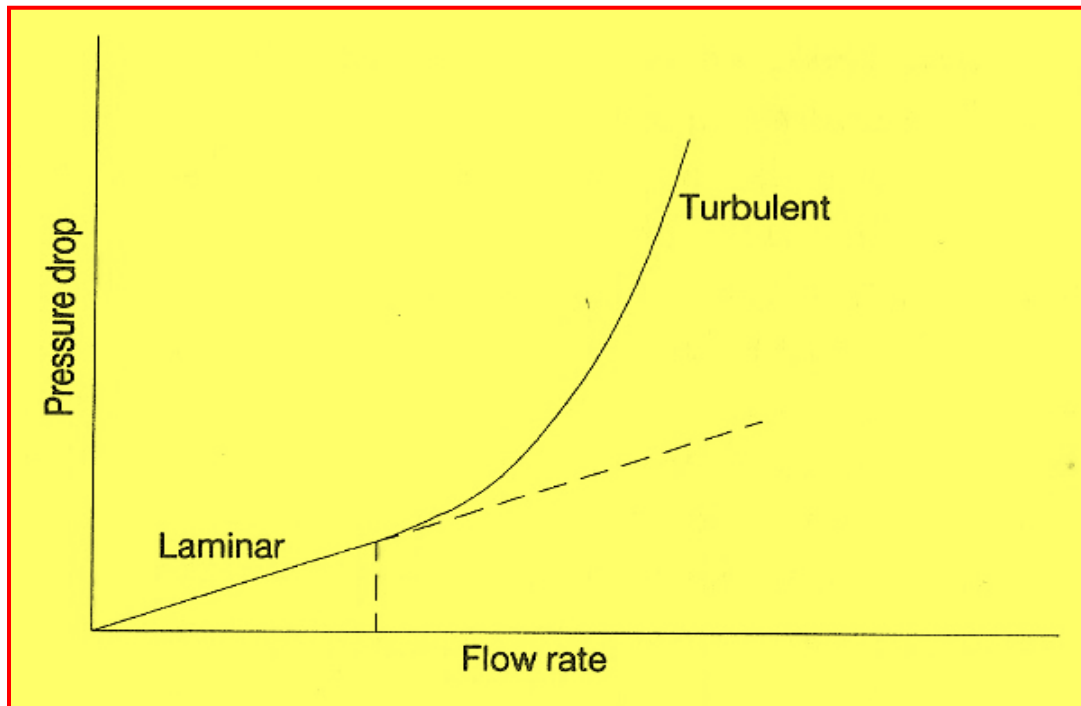

**Figure 1-5.** The relationship between pressure drop and flow rate in a pipe.

Measurements with different fluids, in pipes of various diameters, have shown that for **Newtonian** fluids the transition from laminar to turbulent flow takes place a **critical value** of the quantity  $\rho u d_i / \mu$  in which  $u$  is the volumetric average velocity of the fluid  $d_i$  is the internal diameter of pipe, and  $\rho$  and  $\mu$  are the fluid's density and viscosity respectively. This quantity is known as the Reynolds number **Re** after Osborne Reynolds who made his celebrated flow visualization experiments in **1883**.

$$Re = \frac{\rho u d_i}{\mu} \quad (1.5)$$

The **Reynolds number** is an example of a dimensionless group: its value is independent of the system of units used.

The **volumetric average velocity** is calculated by **dividing** the volumetric flow rate by the flow area ( $\pi d_i^2 / 4$ ). The flow in a round pipe is **laminar** if the **Re** is less than approximately **2100**. The flow in a round pipe is **turbulent** if the **Re** is greater than approximately **4000**. For **Re** between these **two limits**, the flow may switch between laminar and turbulent conditions in an apparently random fashion (**transitional flow**).

#### 1-4.2. **Compressible and incompressible flow**

All **fluids** are **compressible** to some extent but the compressibility of **liquids** is so **low** that they can be being **incompressible**. **Gases** are much **more** compressible **than liquids** but if the pressure of a flowing gas changes little, and the temperature is sensibly constant, then the **density** will be **nearly constant**. When the **fluid density** remains **constant**, the flow is described as **incompressible**. Thus gas flow in which pressure changes are small compared with the average pressure may be treated in same way as the flow of liquids.

When the **density** of the **gas** changes **significantly**, the flow is described as **compressible** and it is necessary to take the density variation into account in making flow calculations.

The **speed of sound**,  $C$  is related to changes in pressure and density of the fluid medium through the equation:

$$c = \sqrt{\frac{dp}{d\rho}} \quad (1.6)$$

or in terms of the **bulk modulus**:

$$c = \sqrt{\frac{E_v}{\rho}} \quad (1.7)$$

For gases undergoing an isentropic process,  $E_v = kp$ , so that:

$$c = \sqrt{\frac{kp}{\rho}}$$

and making use of the ideal gas law, it follows that:

$$c = \sqrt{kRT} \quad (1.8)$$

where,  $E_v$  = bulk modulus,  $k$  = specific heat ratio =  $\frac{C_p}{C_v}$ ,  $R$  = gas constant,

and  $T$  = absolute temperature.

Thus for **ideal gases** the **speed of sound** is proportional to the **square root** of the **absolute temperature**. The **speed of sound** in air at various temperatures can be found in tables. **Equation 1.7** is also valid for liquids, and values  $E_v$  can be used to determine the speed of sound in liquids.

When analyzing **rockets**, **spacecraft**, and **other** systems that involve high-speed gas flows **Figure 1-6**, the flow speed is often expressed in terms of the dimensionless **Mach number** defined as:

$$Ma = \frac{V}{c} = \frac{\text{Speed of flow}}{\text{Speed of sound}}$$

where  $c$  is the **speed of sound** whose value is **346 m/s** in air at room temperature at sea level. A flow is called **sonic** when  $Ma = 1$ , subsonic when  $Ma < 1$ , supersonic when  $Ma > 1$ , and hypersonic when  $Ma \gg 1$ .

**Figure 1-6** Schlieren image of a small model of the space shuttle orbiter being tested at **Ma 3** in the supersonic wind tunnel of the Penn State Gas Dynamics Lab. Several oblique shocks are seen in the air surrounding the spacecraft.

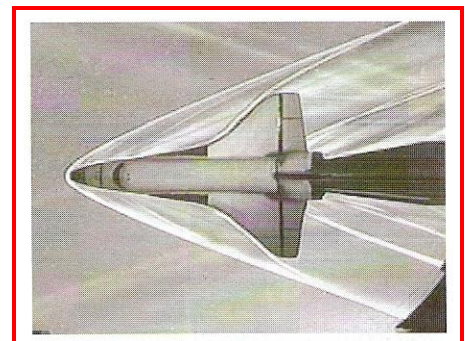

### Example 1.1:

A jet aircraft flies at speed of **550 mi/hr** at an altitude of **35000 ft**, where the temperature is **-66 °F** and the specific heat ratio is  **$k = 1.4$** . **Determine** the ratio of the aircraft,  **$V$** , to that of the speed of sound,  **$C$** , of the specified altitude?

### Solution:

The speed of sound can be calculated as:

$$\begin{aligned} C &= \sqrt{kRT} \\ &= \sqrt{(1.4)(1716 \text{ ft. lb/slug. R})(-66 + 460)\text{R}} \\ &= 973 \text{ ft/s} \end{aligned}$$

Since the air speed is:

$$V = \frac{(550 \text{ mi/hr})(5280 \text{ ft/mi})}{(3600 \text{ s/hr})} = 807 \text{ ft/s}$$

The ratio is:

$$\text{Ma} = \frac{V}{C} = \frac{807 \text{ ft/s}}{973 \text{ ft/s}} = 0.829$$

## 1-4. Energy relationship and the Bernoulli equation

The total energy of a fluid in motion consists of the following components: internal, potential, pressure and kinetic energies. Each of these energies may be considered with reference to an arbitrary base level. It is also convenient to make calculation on unit mass of fluid.

**Internal energy.** This is the energy associated with the physical state of the fluid, ie, the energy of the atoms and molecules resulting from their motion and configuration. Internal energy is a function of temperature. The internal energy per unit mass of fluid is denoted by  **$U$** .

**Potential energy.** This is the energy that a fluid of has by virtue of its position in the Earth's field of gravity. The work required to raise a unit mass of fluid to a height  **$z$**  above an arbitrarily chosen datum is  **$zg$** , where  **$g$**

is acceleration due to gravity. This work is equal to the potential energy of unit mass of fluid above the datum.

**Pressure energy.** This is the energy or work required to introduce the fluid into system without a change of volume. If  $P$  is the pressure and  $V$  is the volume of mass  $m$  of fluid, then  $PV/m$  is the pressure energy per unit mass of fluid. The ratio  $m/V$  is the fluid density  $\rho$ . Thus the pressure energy per unit mass of fluid is equal to  $P/\rho$ .

**Kinetic energy.** This is the energy of fluid motion. The kinetic energy of unit mass of the fluid is  $u^2/2$ , where  $u$  is the velocity of the fluid relative to some fixed body.

**Total energy.** Summing these components, the **total energy  $E$  per unit mass** of fluid is given by the equation:

$$E = U + zg + \frac{P}{\rho} + \frac{u^2}{2} \quad (1.9)$$

**Bernoulli's equation:**

For simple case of the frictionless flow of incompressible fluid the **Bernoulli's equation** will be as follows:

$$gz + \frac{u^2}{2} + \frac{p}{\rho} = \text{constant} \quad (1.10)$$

The constant of **Equation 1.10**, in general varies from one streamline to another but remains constant along a **streamline in steady, frictionless, incompressible** flow. These four assumptions are needed and must be kept in mind when applying this equation. Each term has the dimensions, the units **meter-newton per kilogram**:

$$\frac{\text{m.N}}{\text{kg}} = \frac{\text{m.kg.m/s}^2}{\text{kg}} = \frac{\text{m}^2}{\text{s}^2}$$

because  $1 \text{ N} = 1 \text{ kg}\cdot\text{m}/\text{s}^2$ . Therefore, **Equation 1.10** is energy per unit mass. When it is divided by  $g$ :

$$z + \frac{u^2}{2g} + \frac{p}{\gamma} = \text{constant} \quad (1.11)$$

it can be interpreted as energy per unit weight, meter-newtons per newton (for foot-pounds per pound). This form is particularly convenient for dealing with liquid problems with a free surface. Multiplying **Equation 1.10** by  $\rho$  gives:

$$\gamma z + \frac{\rho u^2}{2} + p = \text{constant} \quad (1.12)$$

which is convenient for gas flow, since elevation changes are frequently unimportant and  $\gamma z$  may be dropped out. In this form each term is meter-newtons per cubic meter, foot-pounds per cubic foot, or energy per unit volume.

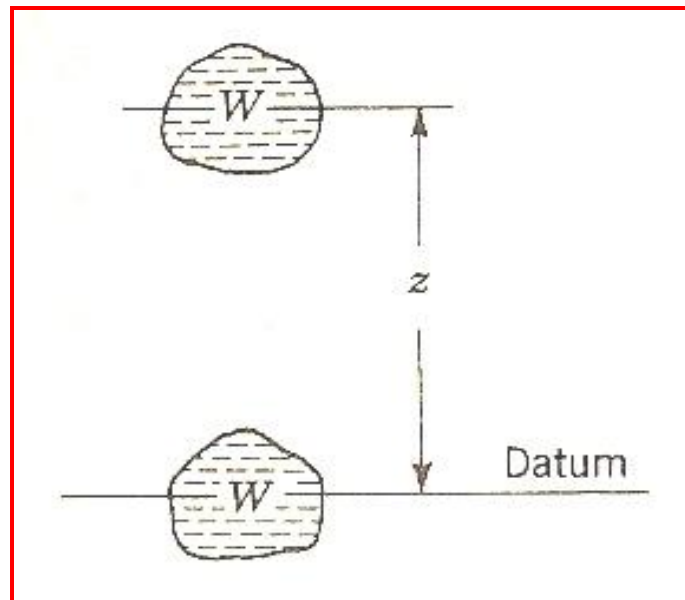
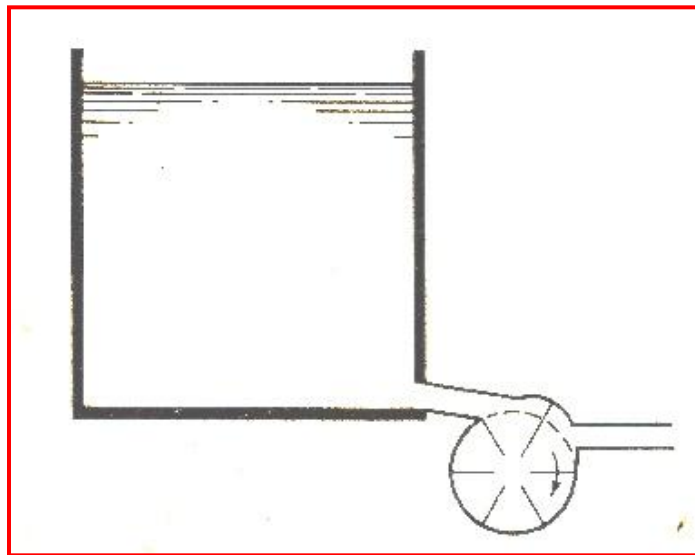

**Figure1-7.** Potential energy.

Each of the terms of **Bernoulli's equation** may be interpreted as a form of energy. In **Equation 1.10** the first term as **potential energy per unit mass**. With reference to **Figure 1-7**, the work needed to lift  $W$  newtons a distance  $z$  meters is  $Wz$ . The mass of  $W$  newtons is  $W/g$ , hence, the potential energy, in meter-newtons per kilogram, is:

$$\frac{W_z}{W/g} = gz$$

The next term,  $\frac{u^2}{2}$  is interpreted as follows. Kinetic energy of a particle of mass is  $\delta m \frac{u^2}{2}$ . To place this on a unit mass basis, divided by  $\delta m$ , thus  $\frac{u^2}{2}$  is meter-newtons per kilogram kinetic energy. The last term,  $\frac{p}{\rho}$ , is the *flow work* or *flow energy* per unit mass. Flow work is net work done by the fluid element on its surroundings while it is flowing. For example, in **Figure 1-8**, imagine a **turbine** consisting of a vaned unit that rotates as fluid passes through it, exerting a torque on its shaft. For a small rotation the pressure drop across a vane times the exposed area of a vane is a force on the rotor. When multiplied by the distance from center of force to axis of the rotor, a torque is obtained. Elemental work done is  $p \delta A ds$  by  $\rho \delta A$  units of mass of flowing fluid, hence, the work per unit mass is  $\frac{p}{\rho}$ . The three energy terms in **Equation 1.10** are referred to as *available energy*.

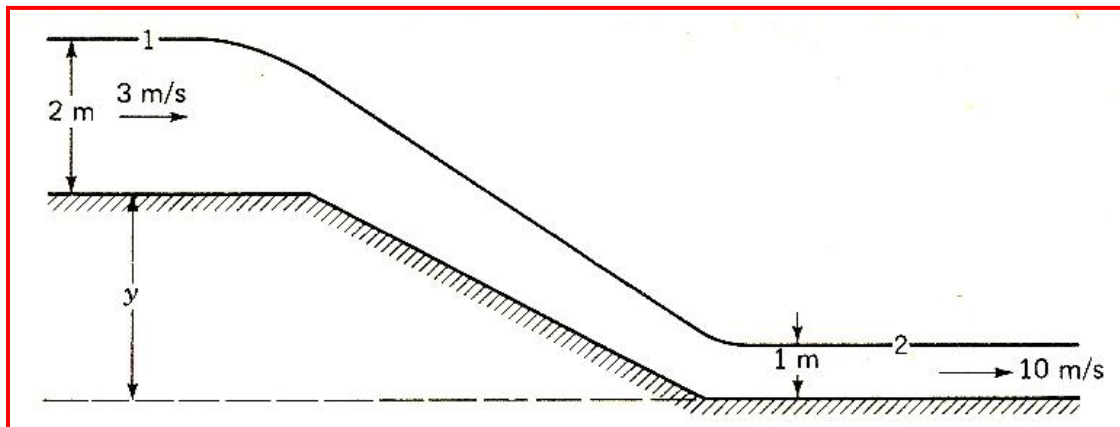

**Figure 1-8** work done by sustained pressure.

By applying **Equation 1.11** to two points on a streamline,

or, 
$$z_1 - z_2 + \frac{p_1 - p_2}{\gamma} + \frac{u_1^2 - u_2^2}{2g} = 0$$

This equation shows that it is the difference in **potential energy**, **flow energy**, and **kinetic energy** that actually has significance in the equation. Thus  $z_1 - z_2$  is independent of the particular **elevation datum**, as it is difference in elevation of the two points. Similarly,  $p_1/\gamma - p_2/\gamma$  is the difference in **pressure heads** expressed in units of **length** of the fluid flowing and is not altered by the particular pressure datum selected. Since the **velocity terms** are not linear, their datum is fixed.



**Figure 1-9.** Open channel-flow.

### **Example 1.2:**

Water is flowing in an open channel in (**Figure 1-9**) at a depth of **2 m** and a velocity of **3 m/s**. it then flows down a chute into another channel where the depth is **1 m** and the velocity **10 m/s**. Assuming frictionless flow, determine the difference in elevation of the channel floors. The velocities are assumed to be uniform over the cross sections, and the pressures hydrostatic.

### **Solution:**

The points **1** and **2** may be selected on the free surface, as shown, or they could be selected at other depth. If the difference in elevation of floors is **y**, **Bernoulli's equation** is:



$$z_1 + \frac{p_1}{\gamma} + \frac{u_1^2}{2g} = z_2 + \frac{p_2}{\gamma} + \frac{u_2^2}{2g}$$

Then  $z_1 = y + 2$ ,  $z_2 = 1$ ,  $u_1 = 3 \text{ m/s}$ ,  $u_2 = 10 \text{ m/s}$ , and  $p_1 = p_2 = 0$ ,

$$y + 2 + 0 + \frac{3^2}{2 \times 9.806} = 1 + 0 + \frac{10^2}{2 \times 9.806}$$

and  $y = 3.64 \text{ m}$ .

### Example 1.3:

(a) Determine the velocity of the efflux from the nozzle in the wall of the reservoir of **Figure 1-10**. (b) Find the discharge through the nozzle.

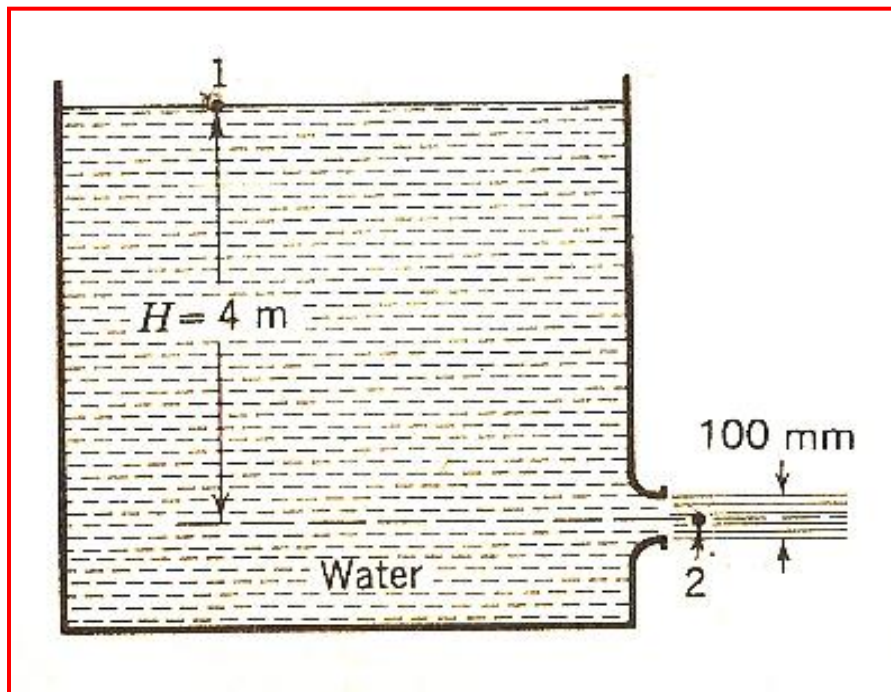

**Figure 1-10.** Flow through nozzle from reservoir.

### Solution:

(a) The jet issues as a cylinder with atmospheric pressure around its periphery. The pressure along its centerline is at atmospheric pressure for

all practical purpose. **Bernoulli's equation** is applied between a point on the water surface and a point downstream from the nozzle.

$$z_1 + \frac{p_1}{\gamma} + \frac{u_1^2}{2g} = z_2 + \frac{p_2}{\gamma} + \frac{u_2^2}{2g}$$

with the pressure datum as a local atmospheric pressure,  $p_1 = p_2 = 0$ , with the elevation datum through **point 2**,  $z_2 = 0$ ,  $z_1 = H$ . The velocity on the surface of the reservoir is **zero** (practically), **hence**,

$$H + 0 + 0 = 0 + 0 + \frac{u_2^2}{2g}$$

and  $u_2 = \sqrt{2gH} = \sqrt{2 \times 9.806 \times 4} = 8.86 \text{ m/s}$

which states that the velocity of efflux is equal to the velocity of free fall from the surface of the reservoir. This is known as **Torricelli's theorem**.

(b) The discharge  $Q$  is the product of velocity of efflux and area of stream,

$$Q = A_2 u_2 = \pi (0.05 \text{ m})^2 (8.86 \text{ m/s}) = 0.07 \text{ m}^3/\text{s} = 70 \text{ l/s.}$$

#### Example 1.4:

A venturi meter, consisting of a converging portion followed by a throat portion of constant diameter and then a gradually diverging portion, is used to determine rate of flow in pipe (**Figure 1-11**). The diameter at section 1 is **6 in**, and at section 2 it is **4 in**. Find the discharge through the pipe when  $p_1 - p_2 = 3$  psi and oil, specific gravity 0.90, is flowing.

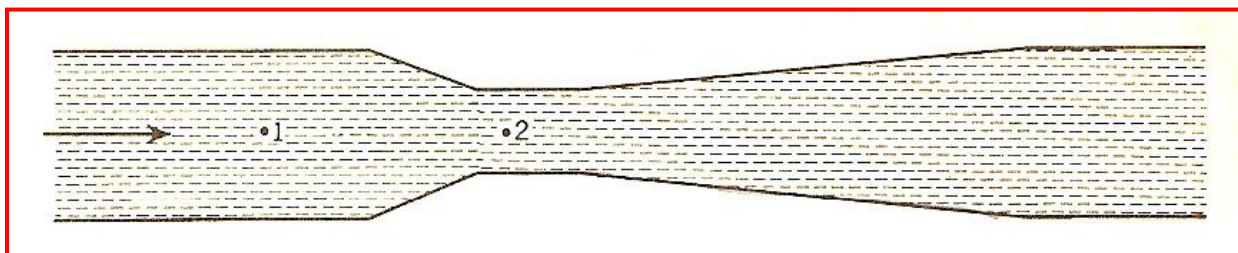

**Figure 1-11.** Venturi meter.

#### Solution:

From the continuity equation:

$$Q = A_1 V_1 = A_2 V_2 = \frac{\pi}{16} V_1 = \frac{\pi}{36} V_2$$

in which  $Q$  is the discharge (volumetric flow rate). By applying Equation 1.11 for  $z_1 = z_2$ ,  $p_1 - p_2 = 3 \times 144 = 432 \text{ lb/ft}^2$ ,  $\gamma = 0.90 \times 62.4 = 56.16 \text{ lb/ft}^3$

$$\frac{p_1 - p_2}{\gamma} = \frac{V_1^2}{2g} - \frac{V_2^2}{2g} \quad \text{or} \quad \frac{432}{56.16} = \frac{Q^2}{\pi^2} \frac{1}{2g} (36^2 - 16^2)$$

Solving for discharge gives  $Q = 2.2 \text{ ft}^3/\text{s}$ .

### 1-5. Continuity equation

First consider steady flow through a portion of the stream tube of Figure 1-12. The control volume comprises the walls of the stream tube between sections 1 and 2, plus the end areas of sections 1 and 2:

$$\int_{CS} \rho \mathbf{v} \cdot d\mathbf{A} = 0 \quad (1.13)$$

which states that the net mass outflow from the control volume must be zero. At section 1 the net mass outflow is  $\rho_1 v_1 \cdot dA_1 = -\rho_1 u_1 \cdot dA_1$ , and at section 2 it is  $\rho_2 v_2 \cdot dA_2 = \rho_2 u_2 \cdot dA_2$ . Since there is no flow through the wall of the stream tube,

$$\rho_1 u_1 \cdot dA_1 = \rho_2 u_2 \cdot dA_2 \quad (1.14)$$

is the continuity equation applied to two sections a stream tube in steady flow.

Where,  $\mathbf{A}$  = Adverse slop,  $A$  = Area,  $\text{m}^2$  or  $\text{ft}^2$ ,  $\mathbf{v}$  = velocity vector,  $\text{m/s}$  or  $\text{ft/s}$ ,  $u$  = velocity, velocity component,  $\text{m/s}$  or  $\text{ft/s}$ .

For a collection of stream tubes, as in Figure 1-13, if  $\rho_1$  is the average density at section 1 and  $\rho_2$  the average density at section 2,  $\text{kg/m}^3$  or  $\text{slug/ft}^3$ ,

$$\dot{m} = \rho_1 V_1 A_1 = \rho_2 V_2 A_2 \quad (1.15)$$

In which  $V_1$ ,  $V_2$  represent average velocities over the cross sections and  $\dot{m}$  is the rate of mass flow,  $\text{m}^3/\text{s}$  or  $\text{ft}^3/\text{s}$ . The average velocity over a cross section is given by:

$$V = \frac{1}{A} \int u \, dA$$

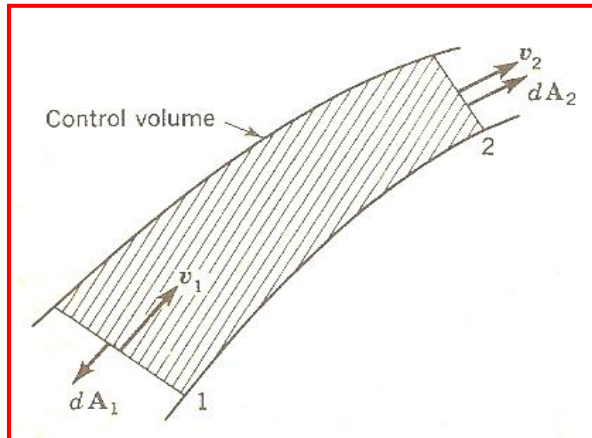

**Figure 1-12.** Steady flow through stream tube.

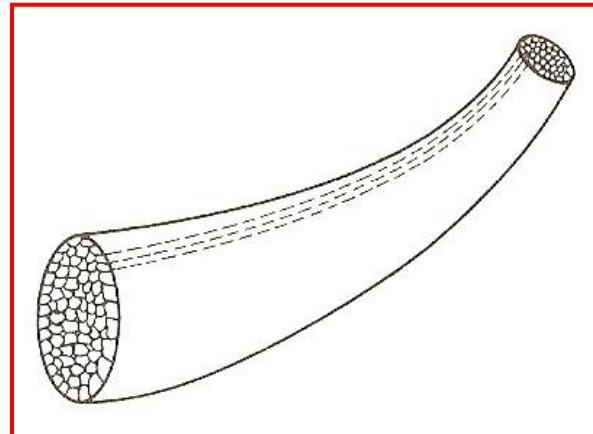

**Figure 1-13.** Collections of stream Tube between fixed boundaries.

If the *discharge*  $Q$  (also called *volumetric flow rate*, or *flow*) is defined as:

$$Q = AV \quad (1.16)$$

the continuity equation may take the form:

$$\dot{m} = \rho_1 Q_1 = \rho_2 Q_2 \quad (1.17)$$

For **incompressible, steady flow**:

$$Q = A_1 V_1 = A_2 V_2 \quad (1.18)$$

is a useful form of the equation.

For constant-density flow, steady or unsteady:

$$\int_{CS} \mathbf{v} \cdot d\mathbf{A} = 0 \quad (1.19)$$

### **Example 1.5:**

At section **1** of a pipe system carrying water (**Figure 1-14**) the velocity is **3 ft/s** and diameter is **2 ft**. At section **2** the diameter **3 ft**. Find the **discharge** and the **velocity** at section **2**.

**Solution:**

From Equation (1.18):

$$Q = V_1 A_1 = (3 \text{ m/s}) \times \frac{\pi}{4} d^2 = 3 \times \frac{\pi}{4} \times (2)^2 = 9.42 \text{ ft}^3/\text{s}$$

and

$$V_2 = \frac{Q}{A_2} = \frac{9.42}{2.25 \times \pi} = 1.33 \text{ ft/s}$$

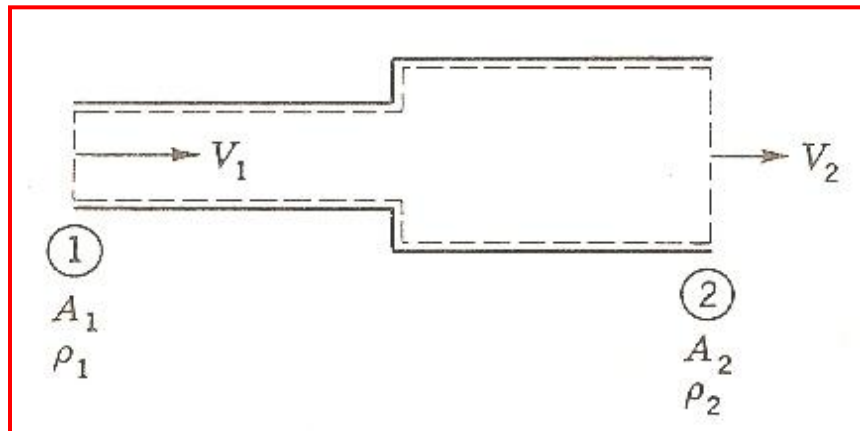

**Figure 1-14.** Control volume for flow through pipes.

## Examples-Chapter 1

### 1-1 Measures of fluid mass, weight, and viscosity:

#### Example 1-1

A (4410 kg) liquid glycerine contained in tank at a temperature of (20 °C). The volume of glycerine in the tank is (3.5 m<sup>3</sup>). The dynamic viscosity of glycerine,  $\mu = 1.5 \text{ Pa}\cdot\text{s}$ . Determine (a) the density of glycerine, (b) the kinematic viscosity of glycerine,  $\nu$ , and (c) its specific weight,  $\gamma$ ?

#### Solution.

$$\text{a) } \rho = \frac{\text{mass}}{\text{volume}} = \frac{m}{v} = \frac{4410 \text{ kg}}{3.5 \text{ m}^3} = 1260 \text{ kg/m}^3$$

$$\text{b) } \nu = \frac{\mu}{\rho} = \frac{1.5 \text{ Pa}\cdot\text{s}}{1260 \text{ kg/m}^3} = \frac{1.5 \frac{\text{N}}{\text{m}^2} \cdot \text{s}}{1260 \frac{\text{kg}}{\text{m}^3}} = 1.5 \frac{\text{kg} \frac{\text{m}}{\text{s}^2}}{\text{m}^2} \cdot \text{s} / 1260 \text{ kg/m}^3$$

$$\nu = 1.19 \times 10^{-3} \text{ m}^2/\text{s}$$

$$\text{c) } \gamma = \rho g = 1260 \frac{\text{kg}}{\text{m}^3} \times 9.81 \frac{\text{m}}{\text{s}^2} = 12348 \frac{\text{N}}{\text{m}^3}$$

$$\gamma = 12.348 \text{ KN/m}^3$$

### Example 1-2

A compressed air tank has a volume of **0.84 ft<sup>3</sup>**. The tank is filled with air at a gage pressure of **50 psi** and a temperature of **70°F**. The atmospheric pressure is **14.7 psi (absolute)**. **Determine** the density of the air and the weight of air in the tank?

### Solution.

The air density can be obtained from the ideal gas equation:

$$\rho = \frac{p}{RT}$$

$$\rho = \frac{\left(50 \frac{\text{lb}}{\text{in}^2} + 14.7 \frac{\text{lb}}{\text{in}^2}\right) \left(144 \frac{\text{in}^2}{\text{ft}^2}\right)}{\left(1716 \text{ ft} \cdot \frac{\text{lb}}{\text{slug} \cdot \text{R}}\right) [(70 + 460) \text{ R}]} = 0.0102 \text{ slugs/ft}^3$$

The weight, **W**, of the air is equal to:

$$W = \rho g \times (\text{volume})$$

$$= (0.0102 \text{ slugs/ft}^3)(32.2 \text{ ft/s}^2)(0.84 \text{ ft}^3) = 0.276 \text{ lb}$$

Since **1 lb = 1 slug.ft/s<sup>2</sup>**)

The repeating the calculations for various values of the pressure, **p**, the results shown in **Figure 1-1**.

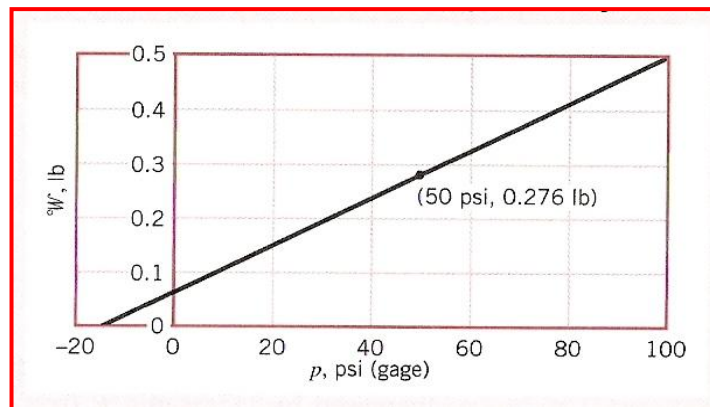

**Figure 1-1.**

### Example1-3

A tank is filled with oil whose density is  $\rho = 850 \text{ kg/m}^3$ . If the volume of the tank is  $V = 2 \text{ m}^3$ . Determine the amount of mass  $m$  in the tank?

### Solution.

**Assumption** Oil is nearly incompressible substance and thus its density is constant.

It is obvious that we can eliminate  $\text{m}^3$  and end up with kg by multiplying these two quantities. Therefore, the formula we are looking for should be:

$$m = \rho V$$

$$m = (850 \text{ kg/m}^3)(2 \text{ m}^3) = 1700 \text{ kg}$$

### Example 1-4

Using unity conversion ratios, show that 1.00 lbm weights 1.00 lbf on earth (Figure 1-2)?

### Solution.

**Assumption** Standard sea-level conditions are measured.

**Properties** The gravitational constant is  $g = 32.174 \text{ ft/s}^2$ .

$$W = mg = (1.00 \text{ lbm})(32.174 \text{ ft/s}^2) \left( \frac{1 \text{ lbf}}{32.174 \text{ lbm.ft/s}^2} \right) = 1.00 \text{ lbf}$$



**Figure 1-2.** A mass of 1 lbm weight 1 lbf on earth.



or in SI units:

$$1 \text{ lbm} = 453.6 \text{ g}$$

$$W = mg = (453.6 \text{ g})(9.81 \text{ m/s}^2) \left( \frac{1 \text{ N}}{1 \text{ kg} \cdot \frac{\text{m}}{\text{s}^2}} \right) \left( \frac{1 \text{ kg}}{1000 \text{ g}} \right) = 4.49 \text{ N}$$

## 1-2 Reynolds number:

### Example 1-5

A dimensionless combination of variables that is important in the study of viscous flow through pipes is called *Reynolds number*, **Re**, defined as  $\frac{\rho V D}{\mu}$

where  $\rho$  is the fluid density,  $V$  the mean fluid velocity,  $D$  the pipe diameter, and  $\mu$  the fluid viscosity. A Newtonian fluid having a viscosity of **0.38** N.s/m<sup>2</sup> and specific gravity of **0.91** flows through a **25 mm** diameter pipe with a velocity of **2.6** m/s. Determine the value of the Reynolds number using: (a) **SI** units, and (b) **BG** units.

### Solution.

(a) The fluid density is calculated from the specific gravity as:

$$\rho = \text{SG } \rho_{H2O@4^\circ\text{C}} = 0.91 (1000 \text{ kg/m}^3) = 910 \text{ kg/m}^3$$

and from definition of the Reynolds number:

$$\begin{aligned} \text{Re} &= \frac{\rho V D}{\mu} = \frac{\left(910 \frac{\text{kg}}{\text{m}^3}\right) \left(2.6 \frac{\text{m}}{\text{s}}\right) (25 \text{ mm}) \left(\frac{10^{-3} \text{ m}}{\text{mm}}\right)}{0.38 \text{ N.s/m}^2} \\ &= 156 \text{ (kg.m/s}^2\text{)/N} \end{aligned}$$

However, since **1N = 1 kg.m/s<sup>2</sup>** it follows that the **Reynolds number** is unitless (dimensionless)-that is:

$$\text{Re} = 156$$

(b) we first convert all the **SI** values of the variables appearing in the Reynolds number to **BG** values by using the conversion factors from Table. Thus:

$$\rho = (910 \text{ kg/m}^3)(1.940 \times 10^{-3}) = 1.77 \text{ slugs/ft}^3$$

$$V = (2.6 \text{ m/s})(3.281) = 8.53 \text{ ft/s}$$

$$D = (0.025 \text{ m})(3.281) = 8.20 \times 10^{-2} \text{ ft}$$

$$\mu = (0.38 \text{ N.s/m}^2)(2.089 \times 10^{-2}) = 7.94 \times 10^{-3} \text{ lb.s/ft}^2$$

and the value of the **Reynolds number** is:

$$\begin{aligned} \text{Re} &= \frac{\rho V D}{\mu} = \frac{(1.77 \text{ slugs/ft}^3)(8.53 \text{ ft/s})(8.20 \times 10^{-2} \text{ ft})}{7.94 \times 10^{-3} \text{ lb.s/ft}^2} \\ &= 156 \text{ (slug.ft/s}^2\text{) / lb} = 156 \end{aligned}$$

since  $1 \text{ lb} = 1 \text{ slug.ft/s}^2$

### 1-3 speed of sound:

#### Example 1-6

Air enters a diffuser in **Figure 1-3** with a speed of 200 m/s. determine (a) the speed of sound and (b) the Mach number at the diffuser inlet when the air temperature is 30 °C ?

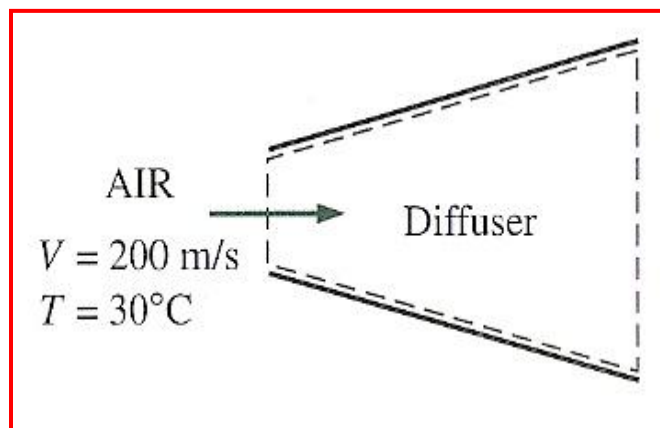

**Figure 1-3** Schematic for Example 1.6.

### Solution.

Air enters a diffuser at high speed. The speed of sound and the Mach number are to be determined at the diffuser inlet.

**Assumption:** Air at the specified conditions behaves as an ideal gas.

**Properties:** The gas constant of air  $R = 0.287 \text{ kJ/kg} \cdot \text{K}$ , and its **specific heat ratio** at  $30^\circ\text{C}$  is **1.4**.

(a) The speed of sound in at  $30^\circ\text{C}$  is determined:

$$c = \sqrt{kRT} = \sqrt{(1.4) \left(0.287 \frac{\text{kJ}}{\text{kg} \cdot \text{K}}\right) (303 \text{ K}) \left(\frac{1000 \text{ m}^2/\text{s}^2}{1 \text{ kJ/kg}}\right)} = 349 \text{ m/s}$$

(b) Then the Mach number becomes:

$$\text{Ma} = \frac{V}{c} = \frac{200 \text{ m/s}}{349 \text{ m/s}} = 0.573$$

**Discussion:** The flow at the diffuser inlet is **subsonic** since  $\text{Ma} < 1$ .

### 1-4 Bernoulli equation:

#### Example 1-7

Water is flowing from a garden hose (**Figure 1-4**). A child places his thumb to cover most of the hose outlet, causing a thin jet of high-speed water to emerge. The pressure in the hose just upstream of his thumb is **400 kPa**. If the hose is held upward, what is the **maximum height** that the jet achieve?

### Solution.

Water from a hose attached to the water main is sprayed into the air. The maximum height the water jet can rise is to be determined.

**Assumption: 1** The flow exiting into the air is **steady**, **incompressible**, and **irrigational** (so that the Bernoulli equation is applicable). **2** the surface tension is effects is negligible. **3** the friction between the water and air is negligible. **4** irreversibilities that occur at the outlet of hose due to abrupt account.

**Properties:** we take the density of water to be  $1000 \text{ kg/m}^3$ .

The velocity inside the hose is relatively low ( $V_1 \ll V_f$ , and thus  $V_1 \cong 0$  compared to  $V_f$ ) and we take the elevation just below the hose outlet as the reference level ( $z_1 = 0$ ). At the top of the water trajectory  $V_2 = 0$ , and atmospheric pressure pertains. Then the **Bernoulli equation** along a streamline from **1** to **2** simplifies to:

$$\frac{P_1}{\rho g} + \frac{V_1^2}{2g} + z_1 = \frac{P_2}{\rho g} + \frac{V_2^2}{2g} + z_2 \rightarrow \frac{P_1}{\rho g} = \frac{P_{\text{atm}}}{\rho g} + z_2$$

Solving for  $z_2$  and substituting:

$$z_2 = \frac{P_1 - P_{\text{atm}}}{\rho g} = \frac{P_{1,\text{gage}}}{\rho g} = \frac{400 \text{ kPa}}{\left(1000 \frac{\text{kg}}{\text{m}^3}\right) \left(9.81 \frac{\text{m}}{\text{s}^2}\right)} \left(\frac{1000 \frac{\text{N}}{\text{m}^2}}{1 \text{ kPa}}\right) \left(\frac{1 \text{ kg} \cdot \frac{\text{m}}{\text{s}^2}}{1 \text{ N}}\right) = 40.8 \text{ m}$$

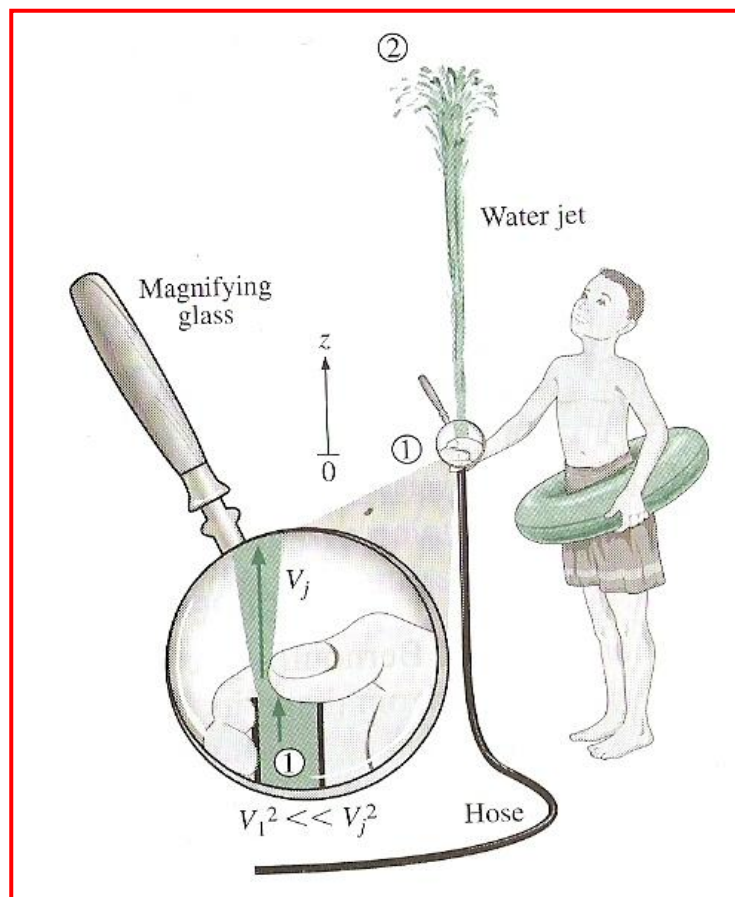

**Figure 1-4. Schematic for Example 1-7.**

### Example 1-8

Consider the flow of air around a bicyclist moving through still air with velocity  $V_0$  as is shown in **Figure 1-5**. Determine the difference in the pressure between points (1) and (2).

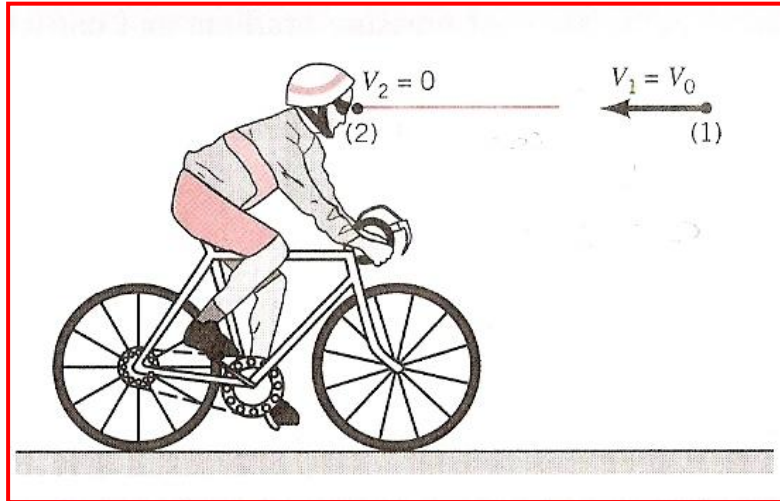

**Figure 1-5.** Schematic for **Example 1-8**.

### Solution.

In a coordinate system fixed to the bike, it appears as though the air is **flowing steadily** toward the bicyclist with speed  $V_0$ . Bernoulli equation can be applied as follows:

$$P_1 + \frac{1}{2} \rho V_1^2 + \gamma z_1 = P_2 + \frac{1}{2} \rho V_2^2 + \gamma z_2$$

We consider (1) to be in the free stream so that  $V_1 = V_0$  and (2) to be at the tip of the bicyclist's nose and assume that  $z_1 = z_2$  and  $V_2 = 0$ . It follows that the pressure of (2) is greater than that at (1) by an amount:

$$P_2 - P_1 = \frac{1}{2} \rho V_1^2 = \frac{1}{2} \rho V_0^2$$

## 1-5 Continuity equation:

### Example 1-9

A stream of water of diameter  $d = 0.1$  m flows steadily from a tank of diameter  $D = 1.0$  m as shown **Figure 1-6a**. **Determine** the flow rate,  $Q$ , needed from the inflow pipe. The water depth is constant at  $h = 2.0$  m.

### Solution.

For steady, inviscid, incompressible flow the **Bernoulli equation** applied between points (1) and (2) is:

$$P_1 + \frac{1}{2} \rho V_1^2 + \gamma z_1 = P_2 + \frac{1}{2} \rho V_2^2 + \gamma z_2 \quad (1)$$

With the assumptions that  $p_1 = p_2 = 0$ ,  $z_1 = h$ , and  $z_2 = 0$ , **Equation 1** becomes:

$$\frac{1}{2} V_1^2 + gh = \frac{1}{2} V_2^2 \quad (2)$$

The water level remains constant ( $h = \text{constant}$ ), there is an average velocity,  $V_1$ , across section (1) because of the flow from the tank. For steady incompressible flow, conservation of mass requires  $Q_1 = Q_2$ , where  $Q = AV$ , thus,  $A_1 V_1 = A_2 V_2$ , or

$$\frac{\pi}{4} D^2 V_1 = \frac{\pi}{4} d^2 V_2$$

$$V_1 = \left(\frac{d}{D}\right)^2 V_2 \quad (3)$$

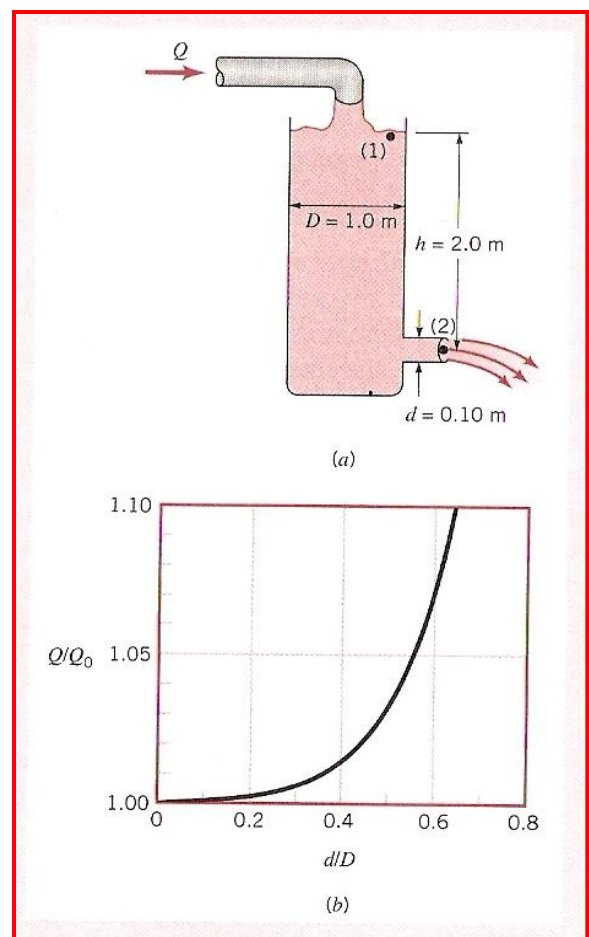

**Figure 1-6. Schematic for Example 1-9.**

Equations **2** and **3** can be combined to give:

$$V_2 = \sqrt{\frac{2gh}{1 - \left(\frac{d}{D}\right)^4}} = \sqrt{\frac{2 \left(9.81 \frac{\text{m}}{\text{s}^2}\right) (2.0 \text{ m})}{1 - \left(\frac{0.1 \text{ m}}{1 \text{ m}}\right)^4}} = 6.26 \text{ m/s}$$

Thus,

$$Q = A_1 V_1 = A_2 V_2 = \frac{\pi}{4} (0.1 \text{ m})^2 \left(6.26 \frac{\text{m}}{\text{s}}\right) = 0.0492 \text{ m}^3/\text{s}$$

In this example we have not neglected the kinetic energy of the water in the tank ( $V_1 \neq 0$ ). If the tank diameter is large compared to the jet diameter ( $D \gg d$ ), Equation 3 indicates that  $V_1 \ll V_2$  and the assumption that  $V_1 \approx 0$  would be reasonable. The error associated with this assumption can be seen by assuming  $V_1 = 0$ , denoted  $Q_0$ . The ratio, written as:

$$\frac{Q}{Q_0} = \frac{V_2}{V_{2,D=\infty}} = \frac{\sqrt{2gh/[1 - \left(\frac{d}{D}\right)^4]}}{\sqrt{2gh}} = \frac{1}{\sqrt{1 - \left(\frac{d}{D}\right)^4}}$$

is plotted in Figure 1-6b. With  $0 < d/D < 0.4$  it follows that  $1 < Q/Q_0 \leq 1.01$ , and the error in assuming  $V_1 = 0$  is less than 1%. thus, it is often reasonable to assume  $V_1 = 0$ .

### Example 1-10

Air flows steadily from a tank, through a hose of  $D = 0.03 \text{ m}$ , and exits to the atmosphere from a nozzle of diameter  $d = 0.01 \text{ m}$  as shown in Figure 1-7. the pressure in the tank remains constant at  $3.0 \text{ kPa}$  (gage), and the atmospheric conditions are standard temperature and pressure. Determine (a) the flow rate and (b) the pressure in the hose?

### Solution.

(a) if the flow is assumed steady, inviscid, and incompressible, we can apply the Bernoulli equation along the streamline from (1) and (2) to (3) as:

$$P_1 + \frac{1}{2} \rho V_1^2 + \gamma z_1 = P_2 + \frac{1}{2} \rho V_2^2 + \gamma z_2 = P_3 + \frac{1}{2} \rho V_3^2 + \gamma z_3$$

With the assumption that  $z_1 = z_2 = z_3$  (horizontal hose),  $V_1 = 0$  (large tank), and  $P_3 = 0$  (free jet) this becomes:

$$V_3 = \sqrt{\frac{2P_1}{\rho}}$$

and

$$P_2 = P_1 - \frac{1}{2} \rho V_2^2 \quad (1)$$

the density of the air in the tank is obtained from the perfect gas law, using standard absolute pressure and temperature, as:

$$\rho = \frac{P_1}{RT_1} = [(3.0 + 101) \text{ kN/m}^2] \times \frac{10^3 \text{ N/kN}}{\left(286.9 \text{ N} \cdot \frac{\text{m}}{\text{kg} \cdot \text{K}}\right)(15 + 273) \text{ K}} = 1.26 \text{ kg/m}^3$$

Thus, we find that:

$$V_3 = \sqrt{\frac{2 \left(3.0 \times 10^3 \frac{\text{N}}{\text{m}^2}\right)}{1.26 \text{ kg/m}^3}} = 69.0 \text{ m/s}$$

or

$$Q = A_3 V_3 = \frac{\pi}{4} d^2 V_3 = \frac{\pi}{4} (0.01 \text{ m})^2 (69.0 \text{ m/s}) = 0.00542 \text{ m}^3/\text{s}$$

(b) The pressure within the hose can be obtained from Equation 1 and the continuity equation:

$$A_2 V_2 = A_3 V_3$$

Hence,

$$V_2 = A_3 V_3 / A_2 = \left(\frac{d}{D}\right)^2 V_3 = \left(\frac{0.01 \text{ m}}{0.03 \text{ m}}\right)^2 (69.0 \text{ m/s}) = 7.67 \text{ m/s}$$



and from **Equation 1**:

$$P_2 = 3.0 \times 10^3 \text{ N/m}^2 - \frac{1}{2} (1.26 \text{ kg/m}^3)(7.67 \text{ m/s})^2$$

$$= (3000 - 37.1) \text{ N/m}^2 = \mathbf{2963 \text{ N/m}^2}$$

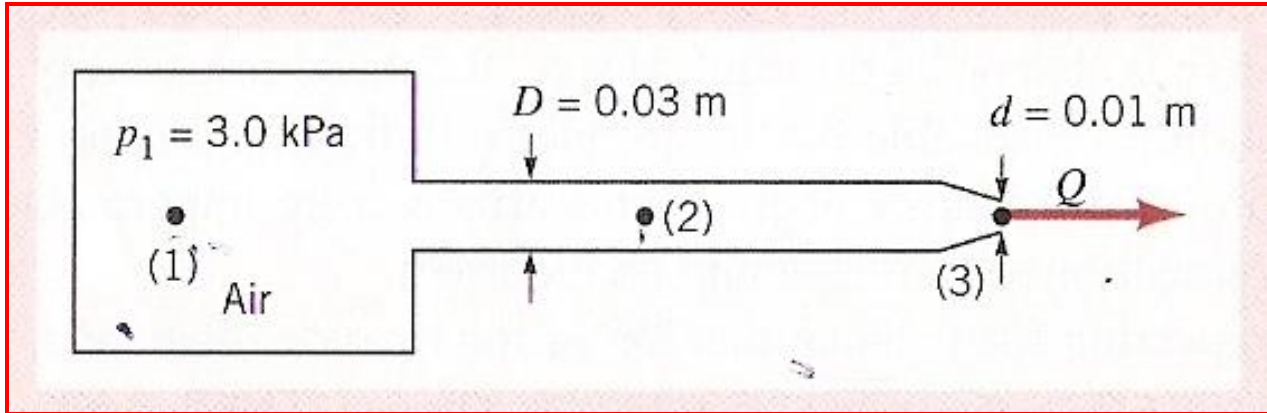

**Figure 1-7. Schematic for Example 1-10.**

### **Example 1-11**

Water at  $60^\circ\text{F}$  is siphoned from a large tank through a constant diameter hose as shown **Figure 1-8**. The end of the siphon is **5 ft** below the bottom of the tank. Atmospheric pressure is **14.7 psia**. Determine the maximum height of the hill,  $H$ , over which can be siphoned without cavitation occurring?

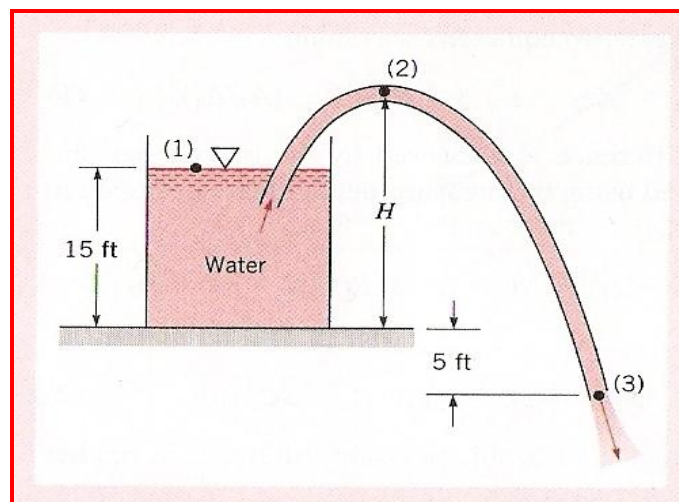

**Figure 1-8. Schematic for Example 1-11.**

### Solution.

If the flow is steady, inviscid, and incompressible, we can apply **Bernoulli equation** along the streamline from (1) to (2) to (3) as follows:

$$P_1 + \frac{1}{2} \rho V_1^2 + \gamma z_1 = P_2 + \frac{1}{2} \rho V_2^2 + \gamma z_2 = P_3 + \frac{1}{2} \rho V_3^2 + \gamma z_3 \quad (1)$$

With the tank bottom as datum, we have  $z_1 = 15 \text{ ft}$ ,  $z_2 = H$ , and  $z_3 = -5 \text{ ft}$ . also,  $V_1 = 0$  (large tank),  $P_1 = 0$  (open tank),  $P_3 = 0$  (free jet), and from the continuity equation  $A_2 V_2 = A_3 V_3$ , or because the hose is constant diameter,  $V_2 = V_3$ . Thus, the speed of the fluid in the hose is determined from **Equation 1** to be:

$$V_3 = \sqrt{2g(z_1 - z_3)} = \sqrt{2(32.2 \text{ ft/s}^2)[15 - (-5)]\text{ft}} = 35.9 \text{ ft/s} = V_2$$

Use **Equation 1** between (1) and (2) then gives the pressure  $P_2$  at the top of the hill as:

$$P_2 = P_1 + \frac{1}{2} \rho V_1^2 + \gamma z_1 - \frac{1}{2} \rho V_2^2 - \gamma z_2$$

$$P_2 = \gamma (z_1 - z_2) - \frac{1}{2} \rho V_2^2 \quad (2)$$

From table, the **vapor pressure** of water at  $60^\circ\text{F}$  is **0.256 psia**. Hence, for incipient cavitation the lowest pressure in the system will  $P = 0.256 \text{ psia}$ . Careful consideration of **Equation 2** and **Figure 1-8** will show that this lowest pressure will occur at the top of the hill. Because we have used gage pressure at point (1) ( $P_1 = 0$ ), we must use gage pressure at point (2) also. Thus,  $P_2 = 0.256 - 14.7 = -14.4 \text{ psi}$  and **Equation 2** gives:

$$(-14.4 \text{ lb/in}^2)(144 \text{ in}^2/\text{ft}^2) = (62.4 \text{ lb/ft}^3)(15 - H)\text{ft} - \frac{1}{2} (1.94 \text{ slugs/ft}^3)(35.9 \text{ ft/s})^2$$

or  $H = 28.7 \text{ ft}$

for larger values of  $H$ , vapor bubbles will form at point (2) and the siphon action may stop.