

## Parallel Circuits

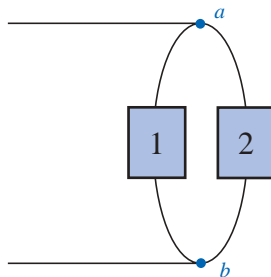
### 6.1 INTRODUCTION

Two network configurations, series and parallel, form the framework for some of the most complex network structures. A clear understanding of each will pay enormous dividends as more complex methods and networks are examined. The series connection was discussed in detail in the last chapter. We will now examine the **parallel circuit** and all the methods and laws associated with this important configuration.

### 6.2 PARALLEL ELEMENTS

*Two elements, branches, or networks are in parallel if they have two points in common.*

In Fig. 6.1, for example, elements 1 and 2 have terminals  $a$  and  $b$  in common; they are therefore in parallel.



**FIG. 6.1**  
*Parallel elements.*

In Fig. 6.2, all the elements are in parallel because they satisfy the above criterion. Three configurations are provided to demonstrate how the parallel networks can be drawn. Do not let the squaring of the con-

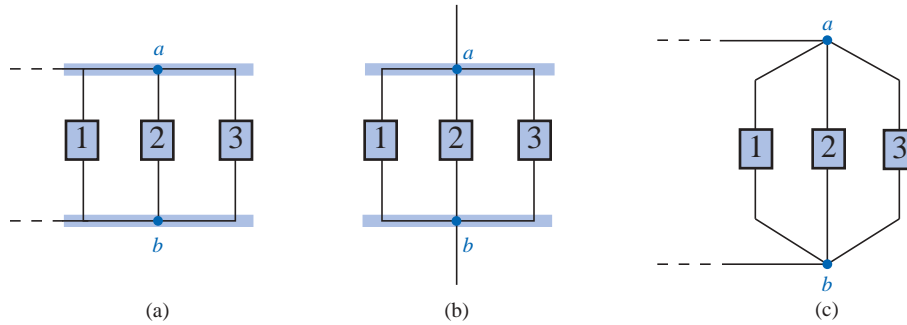


FIG. 6.2

Different ways in which three parallel elements may appear.

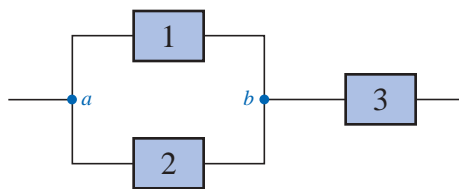


FIG. 6.3

Network in which 1 and 2 are in parallel and 3 is in series with the parallel combination of 1 and 2.

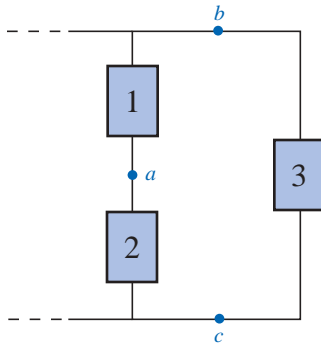


FIG. 6.4

Network in which 1 and 2 are in series and 3 is in parallel with the series combination of 1 and 2.

nection at the top and bottom of Fig. 6.2(a) and (b) cloud the fact that all the elements are connected to one terminal point at the top and bottom, as shown in Fig. 6.2(c).

In Fig. 6.3, elements 1 and 2 are in parallel because they have terminals *a* and *b* in common. The parallel combination of 1 and 2 is then in series with element 3 due to the common terminal point *b*.

In Fig. 6.4, elements 1 and 2 are in series due to the common point *a*, but the series combination of 1 and 2 is in parallel with element 3 as defined by the common terminal connections at *b* and *c*.

In Figs. 6.1 through 6.4, the numbered boxes were used as a general symbol representing single resistive elements, or batteries, or complex network configurations.

Common examples of parallel elements include the rungs of a ladder, the tying of more than one rope between two points to increase the strength of the connection, and the use of pipes between two points to split the water between the two points at a ratio determined by the area of the pipes.

### 6.3 TOTAL CONDUCTANCE AND RESISTANCE

Recall that for series resistors, the total resistance is the sum of the resistor values.

*For parallel elements, the total conductance is the sum of the individual conductances.*

That is, for the parallel network of Fig. 6.5, we write

$$G_T = G_1 + G_2 + G_3 + \dots + G_N \tag{6.1}$$

Since increasing levels of conductance will establish higher current levels, the more terms appearing in Eq. (6.1), the higher the input cur-

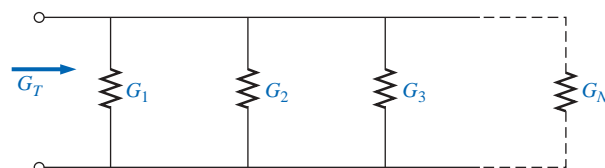


FIG. 6.5

Determining the total conductance of parallel conductances.

rent level. In other words, as the number of resistors in parallel increases, the input current level will increase for the same applied voltage—the opposite effect of increasing the number of resistors in series.

Substituting resistor values for the network of Fig. 6.5 will result in the network of Fig. 6.6. Since  $G = 1/R$ , the total resistance for the network can be determined by direct substitution into Eq. (6.1):

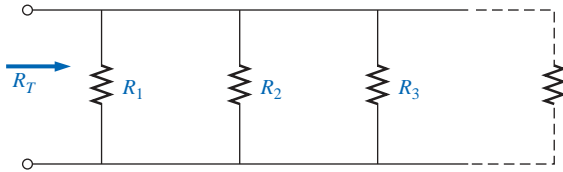


FIG. 6.6

Determining the total resistance of parallel resistors.

$$\frac{1}{R_T} = \frac{1}{R_1} + \frac{1}{R_2} + \frac{1}{R_3} + \dots + \frac{1}{R_N} \quad (6.2)$$

Note that the equation is for 1 divided by the total resistance rather than the total resistance. Once the sum of the terms to the right of the equals sign has been determined, it will then be necessary to divide the result into 1 to determine the total resistance. The following examples will demonstrate the additional calculations introduced by the inverse relationship.

**EXAMPLE 6.1** Determine the total conductance and resistance for the parallel network of Fig. 6.7.

**Solution:**

$$G_T = G_1 + G_2 = \frac{1}{3 \Omega} + \frac{1}{6 \Omega} = 0.333 \text{ S} + 0.167 \text{ S} = \mathbf{0.5 \text{ S}}$$

and

$$R_T = \frac{1}{G_T} = \frac{1}{0.5 \text{ S}} = \mathbf{2 \Omega}$$

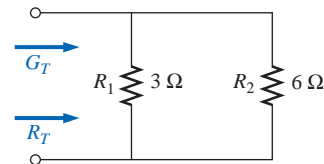


FIG. 6.7

Example 6.1.

**EXAMPLE 6.2** Determine the effect on the total conductance and resistance of the network of Fig. 6.7 if another resistor of 10  $\Omega$  were added in parallel with the other elements.

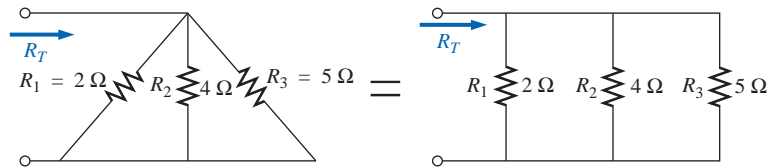
**Solution:**

$$G_T = 0.5 \text{ S} + \frac{1}{10 \Omega} = 0.5 \text{ S} + 0.1 \text{ S} = \mathbf{0.6 \text{ S}}$$

$$R_T = \frac{1}{G_T} = \frac{1}{0.6 \text{ S}} \cong \mathbf{1.667 \Omega}$$

Note, as mentioned above, that adding additional terms increases the conductance level and decreases the resistance level.

**EXAMPLE 6.3** Determine the total resistance for the network of Fig. 6.8.



**FIG. 6.8**  
Example 6.3.

**Solution:**

$$\begin{aligned}\frac{1}{R_T} &= \frac{1}{R_1} + \frac{1}{R_2} + \frac{1}{R_3} \\ &= \frac{1}{2\ \Omega} + \frac{1}{4\ \Omega} + \frac{1}{5\ \Omega} = 0.5\ \text{S} + 0.25\ \text{S} + 0.2\ \text{S} \\ &= 0.95\ \text{S}\end{aligned}$$

and 
$$R_T = \frac{1}{0.95\ \text{S}} = \mathbf{1.053\ \Omega}$$

The above examples demonstrate an interesting and useful (for checking purposes) characteristic of parallel resistors:

***The total resistance of parallel resistors is always less than the value of the smallest resistor.***

In addition, the wider the spread in numerical value between two parallel resistors, the closer the total resistance will be to the smaller resistor. For instance, the total resistance of  $3\ \Omega$  in parallel with  $6\ \Omega$  is  $2\ \Omega$ , as demonstrated in Example 6.1. However, the total resistance of  $3\ \Omega$  in parallel with  $60\ \Omega$  is  $2.85\ \Omega$ , which is much closer to the value of the smaller resistor.

For *equal* resistors in parallel, the equation becomes significantly easier to apply. For  $N$  equal resistors in parallel, Equation (6.2) becomes

$$\begin{aligned}\frac{1}{R_T} &= \frac{1}{R} + \frac{1}{R} + \frac{1}{R} + \cdots + \frac{1}{R} \\ &= \underbrace{\frac{1}{R} + \frac{1}{R} + \frac{1}{R} + \cdots + \frac{1}{R}}_N \\ &= N\left(\frac{1}{R}\right)\end{aligned}$$

and

$$\boxed{R_T = \frac{R}{N}} \quad (6.3)$$

In other words, the total resistance of  $N$  parallel resistors of equal value is the resistance of *one* resistor divided by the number ( $N$ ) of parallel elements.

For conductance levels, we have

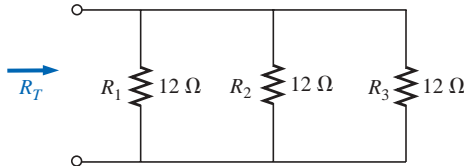
$$\boxed{G_T = NG} \quad (6.4)$$

**EXAMPLE 6.4**

- a. Find the total resistance of the network of Fig. 6.9.
- b. Calculate the total resistance for the network of Fig. 6.10.

**Solutions:**

a. Figure 6.9 is redrawn in Fig. 6.11:



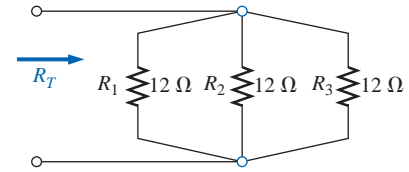
**FIG. 6.11**

Redrawing the network of Fig. 6.9.

$$R_T = \frac{R}{N} = \frac{12 \Omega}{3} = 4 \Omega$$

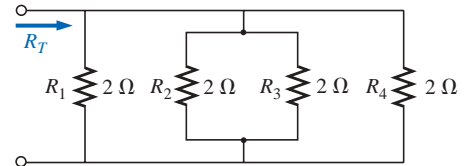
b. Figure 6.10 is redrawn in Fig. 6.12:

$$R_T = \frac{R}{N} = \frac{2 \Omega}{4} = 0.5 \Omega$$



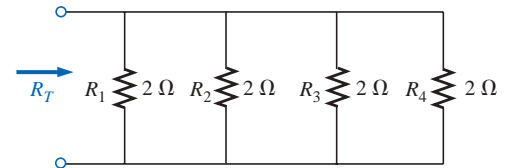
**FIG. 6.9**

Example 6.4: three parallel resistors of equal value.



**FIG. 6.10**

Example 6.4: four parallel resistors of equal value.



**FIG. 6.12**

Redrawing the network of Fig. 6.10.

In the vast majority of situations, only two or three parallel resistive elements need to be combined. With this in mind, the following equations were developed to reduce the effects of the inverse relationship when determining  $R_T$ .

For two parallel resistors, we write

$$\frac{1}{R_T} = \frac{1}{R_1} + \frac{1}{R_2}$$

Multiplying the top and bottom of each term of the right side of the equation by the other resistor will result in

$$\begin{aligned} \frac{1}{R_T} &= \left(\frac{R_2}{R_2}\right) \frac{1}{R_1} + \left(\frac{R_1}{R_1}\right) \frac{1}{R_2} = \frac{R_2}{R_1 R_2} + \frac{R_1}{R_1 R_2} \\ &= \frac{R_2 + R_1}{R_1 R_2} \end{aligned}$$

and

$$R_T = \frac{R_1 R_2}{R_1 + R_2} \tag{6.5}$$

In words,

*the total resistance of two parallel resistors is the product of the two divided by their sum.*

For three parallel resistors, the equation for  $R_T$  becomes

$$R_T = \frac{1}{\frac{1}{R_1} + \frac{1}{R_2} + \frac{1}{R_3}} \tag{6.6a}$$

requiring that we be careful with all the divisions into 1.

Equation (6.6a) can also be expanded into the form of Eq. (6.5), resulting in Eq. (6.6b):

$$R_T = \frac{R_1 R_2 R_3}{R_1 R_2 + R_1 R_3 + R_2 R_3} \quad (6.6b)$$

with the denominator showing all the possible product combinations of the resistors taken two at a time. An alternative to either form of Eq. (6.6) is to simply apply Eq. (6.5) twice, as will be demonstrated in Example 6.6.

---

**EXAMPLE 6.5** Repeat Example 6.1 using Eq. (6.5).

**Solution:**

$$R_T = \frac{R_1 R_2}{R_1 + R_2} = \frac{(3 \Omega)(6 \Omega)}{3 \Omega + 6 \Omega} = \frac{18 \Omega}{9} = 2 \Omega$$

---

**EXAMPLE 6.6** Repeat Example 6.3 using Eq. (6.6a).

**Solution:**

$$\begin{aligned} R_T &= \frac{1}{\frac{1}{R_1} + \frac{1}{R_2} + \frac{1}{R_3}} \\ &= \frac{1}{\frac{1}{2 \Omega} + \frac{1}{4 \Omega} + \frac{1}{5 \Omega}} = \frac{1}{0.5 + 0.25 + 0.2} \\ &= \frac{1}{0.95} = 1.053 \Omega \end{aligned}$$

Applying Eq. (6.5) twice yields

$$\begin{aligned} R'_T &= 2 \Omega \parallel 4 \Omega = \frac{(2 \Omega)(4 \Omega)}{2 \Omega + 4 \Omega} = \frac{4}{3} \Omega \\ R_T &= R'_T \parallel 5 \Omega = \frac{\left(\frac{4}{3} \Omega\right)(5 \Omega)}{\frac{4}{3} \Omega + 5 \Omega} = 1.053 \Omega \end{aligned}$$

---

Recall that series elements can be interchanged without affecting the magnitude of the total resistance or current. In parallel networks,

*parallel elements can be interchanged without changing the total resistance or input current.*

Note in the next example how redrawing the network can often clarify which operations and equations should be applied.

---

**EXAMPLE 6.7** Calculate the total resistance of the parallel network of Fig. 6.13.

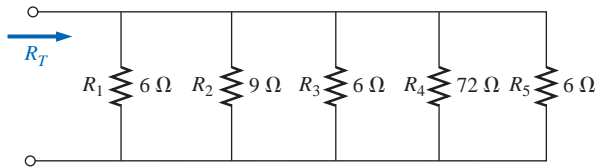


FIG. 6.13

Example 6.7.

**Solution:** The network is redrawn in Fig. 6.14:

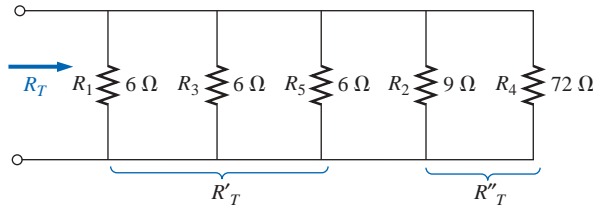


FIG. 6.14

Network of Fig. 6.13 redrawn.

$$R'_T = \frac{R}{N} = \frac{6 \Omega}{3} = 2 \Omega$$

$$R''_T = \frac{R_2 R_4}{R_2 + R_4} = \frac{(9 \Omega)(72 \Omega)}{9 \Omega + 72 \Omega} = \frac{648 \Omega}{81} = 8 \Omega$$

and

$$R_T = R'_T \parallel R''_T$$

↑ In parallel with

$$= \frac{R'_T R''_T}{R'_T + R''_T} = \frac{(2 \Omega)(8 \Omega)}{2 \Omega + 8 \Omega} = \frac{16 \Omega}{10} = 1.6 \Omega$$

The preceding examples show direct substitution, in which once the proper equation is defined, it is only a matter of plugging in the numbers and performing the required algebraic maneuvers. The next two examples have a design orientation, where specific network parameters are defined and the circuit elements must be determined.

**EXAMPLE 6.8** Determine the value of  $R_2$  in Fig. 6.15 to establish a total resistance of 9 kΩ.

**Solution:**

$$R_T = \frac{R_1 R_2}{R_1 + R_2}$$

$$R_T(R_1 + R_2) = R_1 R_2$$

$$R_T R_1 + R_T R_2 = R_1 R_2$$

$$R_T R_1 = R_1 R_2 - R_T R_2$$

$$R_T R_1 = (R_1 - R_T) R_2$$

and

$$R_2 = \frac{R_T R_1}{R_1 - R_T} \tag{6.7}$$

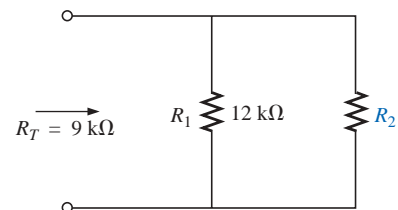
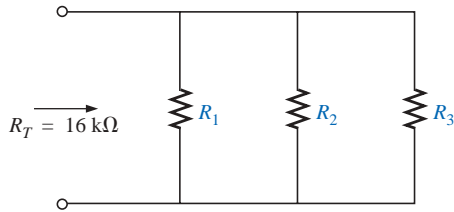
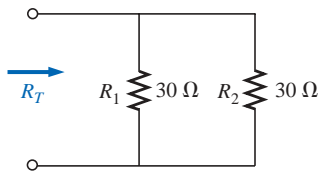


FIG. 6.15

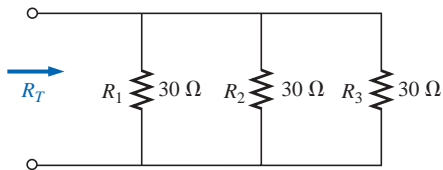
Example 6.8.



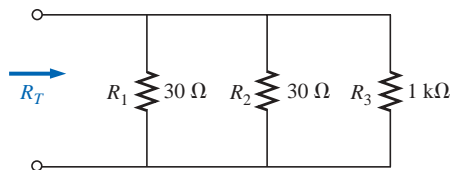
**FIG. 6.16**  
Example 6.9.



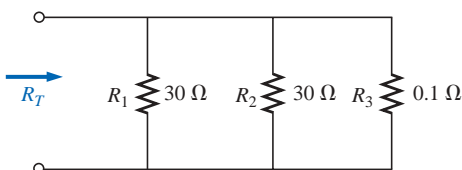
**FIG. 6.17**  
Example 6.10: two equal, parallel resistors.



**FIG. 6.18**  
Adding a third parallel resistor of equal value to the network of Fig. 6.17.



**FIG. 6.19**  
Adding a much larger parallel resistor to the network of Fig. 6.17.



**FIG. 6.20**  
Adding a much smaller parallel resistor to the network of Fig. 6.17.

Substituting values:

$$R_2 = \frac{(9 \text{ k}\Omega)(12 \text{ k}\Omega)}{12 \text{ k}\Omega - 9 \text{ k}\Omega}$$

$$= \frac{108 \text{ k}\Omega}{3} = 36 \text{ k}\Omega$$

**EXAMPLE 6.9** Determine the values of  $R_1$ ,  $R_2$ , and  $R_3$  in Fig. 6.16 if  $R_2 = 2R_1$  and  $R_3 = 2R_2$  and the total resistance is  $16 \text{ k}\Omega$ .

**Solution:**

$$\frac{1}{R_T} = \frac{1}{R_1} + \frac{1}{R_2} + \frac{1}{R_3}$$

$$\frac{1}{16 \text{ k}\Omega} = \frac{1}{R_1} + \frac{1}{2R_1} + \frac{1}{4R_1}$$

since

$$R_3 = 2R_2 = 2(2R_1) = 4R_1$$

and

$$\frac{1}{16 \text{ k}\Omega} = \frac{1}{R_1} + \frac{1}{2} \left( \frac{1}{R_1} \right) + \frac{1}{4} \left( \frac{1}{R_1} \right)$$

$$\frac{1}{16 \text{ k}\Omega} = 1.75 \left( \frac{1}{R_1} \right)$$

with

$$R_1 = 1.75(16 \text{ k}\Omega) = 28 \text{ k}\Omega$$

Recall for series circuits that the total resistance will always increase as additional elements are added in series.

*For parallel resistors, the total resistance will always decrease as additional elements are added in parallel.*

The next example demonstrates this unique characteristic of parallel resistors.

**EXAMPLE 6.10**

- Determine the total resistance of the network of Fig. 6.17.
- What is the effect on the total resistance of the network of Fig. 6.17 if an additional resistor of the same value is added, as shown in Fig. 6.18?
- What is the effect on the total resistance of the network of Fig. 6.17 if a very large resistance is added in parallel, as shown in Fig. 6.19?
- What is the effect on the total resistance of the network of Fig. 6.17 if a very small resistance is added in parallel, as shown in Fig. 6.20?

**Solutions:**

a.  $R_T = 30 \Omega \parallel 30 \Omega = \frac{30 \Omega}{2} = 15 \Omega$

b.  $R_T = 30 \Omega \parallel 30 \Omega \parallel 30 \Omega = \frac{30 \Omega}{3} = 10 \Omega < 15 \Omega$

$R_T$  decreased

c.  $R_T = 30 \Omega \parallel 30 \Omega \parallel 1 \text{ k}\Omega = 15 \Omega \parallel 1 \text{ k}\Omega$   
 $= \frac{(15 \Omega)(1000 \Omega)}{15 \Omega + 1000 \Omega} = 14.778 \Omega < 15 \Omega$

Small decrease in  $R_T$



$$d. R_T = 30 \Omega \parallel 30 \Omega \parallel 0.1 \Omega = 15 \Omega \parallel 0.1 \Omega$$

$$= \frac{(15 \Omega)(0.1 \Omega)}{15 \Omega + 0.1 \Omega} = \mathbf{0.099 \Omega} < 15 \Omega$$

Significant decrease in  $R_T$

In each case the total resistance of the network decreased with the increase of an additional parallel resistive element, no matter how large or small. Note also that the total resistance is also smaller than that of the smallest parallel element.

### 6.4 PARALLEL CIRCUITS

The network of Fig. 6.21 is the simplest of parallel circuits. All the elements have terminals  $a$  and  $b$  in common. The total resistance is determined by  $R_T = R_1 R_2 / (R_1 + R_2)$ , and the source current by  $I_s = E / R_T$ . Throughout the text, the subscript  $s$  will be used to denote a property of the source. Since the terminals of the battery are connected directly across the resistors  $R_1$  and  $R_2$ , the following should be obvious:

**The voltage across parallel elements is the same.**

Using this fact will result in

$$V_1 = V_2 = E$$

and

$$I_1 = \frac{V_1}{R_1} = \frac{E}{R_1}$$

with

$$I_2 = \frac{V_2}{R_2} = \frac{E}{R_2}$$

If we take the equation for the total resistance and multiply both sides by the applied voltage, we obtain

$$E \left( \frac{1}{R_T} \right) = E \left( \frac{1}{R_1} + \frac{1}{R_2} \right)$$

and

$$\frac{E}{R_T} = \frac{E}{R_1} + \frac{E}{R_2}$$

Substituting the Ohm's law relationships appearing above, we find that the source current

$$I_s = I_1 + I_2$$

permitting the following conclusion:

**For single-source parallel networks, the source current ( $I_s$ ) is equal to the sum of the individual branch currents.**

The power dissipated by the resistors and delivered by the source can be determined from

$$P_1 = V_1 I_1 = I_1^2 R_1 = \frac{V_1^2}{R_1}$$

$$P_2 = V_2 I_2 = I_2^2 R_2 = \frac{V_2^2}{R_2}$$

$$P_s = E I_s = I_s^2 R_T = \frac{E^2}{R_T}$$

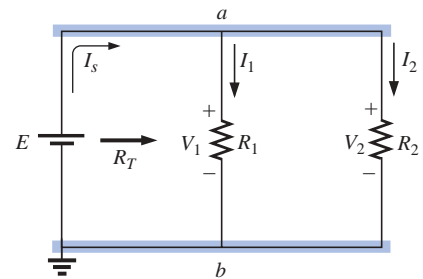
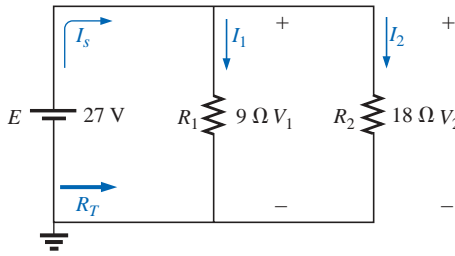


FIG. 6.21  
Parallel network.



**FIG. 6.22**  
Example 6.11.

**EXAMPLE 6.11** For the parallel network of Fig. 6.22:

- Calculate  $R_T$ .
- Determine  $I_s$ .
- Calculate  $I_1$  and  $I_2$ , and demonstrate that  $I_s = I_1 + I_2$ .
- Determine the power to each resistive load.
- Determine the power delivered by the source, and compare it to the total power dissipated by the resistive elements.

**Solutions:**

$$\text{a. } R_T = \frac{R_1 R_2}{R_1 + R_2} = \frac{(9 \Omega)(18 \Omega)}{9 \Omega + 18 \Omega} = \frac{162 \Omega}{27} = \mathbf{6 \Omega}$$

$$\text{b. } I_s = \frac{E}{R_T} = \frac{27 \text{ V}}{6 \Omega} = \mathbf{4.5 \text{ A}}$$

$$\text{c. } I_1 = \frac{V_1}{R_1} = \frac{E}{R_1} = \frac{27 \text{ V}}{9 \Omega} = \mathbf{3 \text{ A}}$$

$$I_2 = \frac{V_2}{R_2} = \frac{E}{R_2} = \frac{27 \text{ V}}{18 \Omega} = \mathbf{1.5 \text{ A}}$$

$$I_s = I_1 + I_2$$

$$4.5 \text{ A} = 3 \text{ A} + 1.5 \text{ A}$$

$$\mathbf{4.5 \text{ A} = 4.5 \text{ A}} \quad (\text{checks})$$

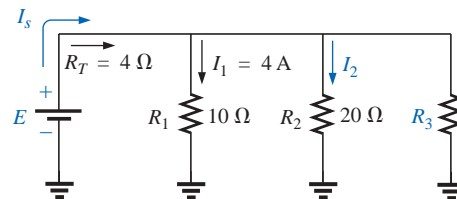
$$\text{d. } P_1 = V_1 I_1 = E I_1 = (27 \text{ V})(3 \text{ A}) = \mathbf{81 \text{ W}}$$

$$P_2 = V_2 I_2 = E I_2 = (27 \text{ V})(1.5 \text{ A}) = \mathbf{40.5 \text{ W}}$$

$$\text{e. } P_s = E I_s = (27 \text{ V})(4.5 \text{ A}) = \mathbf{121.5 \text{ W}}$$

$$= P_1 + P_2 = 81 \text{ W} + 40.5 \text{ W} = \mathbf{121.5 \text{ W}}$$

**EXAMPLE 6.12** Given the information provided in Fig. 6.23:



**FIG. 6.23**  
Example 6.12.

- Determine  $R_3$ .
- Calculate  $E$ .
- Find  $I_s$ .
- Find  $I_2$ .
- Determine  $P_2$ .

**Solutions:**

$$\text{a. } \frac{1}{R_T} = \frac{1}{R_1} + \frac{1}{R_2} + \frac{1}{R_3}$$

$$\frac{1}{4 \Omega} = \frac{1}{10 \Omega} + \frac{1}{20 \Omega} + \frac{1}{R_3}$$

$$0.25 \text{ S} = 0.1 \text{ S} + 0.05 \text{ S} + \frac{1}{R_3}$$

$$0.25 \text{ S} = 0.15 \text{ S} + \frac{1}{R_3}$$

$$\frac{1}{R_3} = 0.1 \text{ S}$$

$$R_3 = \frac{1}{0.1 \text{ S}} = 10 \text{ } \Omega$$

b.  $E = V_1 = I_1 R_1 = (4 \text{ A})(10 \text{ } \Omega) = 40 \text{ V}$

c.  $I_s = \frac{E}{R_T} = \frac{40 \text{ V}}{4 \text{ } \Omega} = 10 \text{ A}$

d.  $I_2 = \frac{V_2}{R_2} = \frac{E}{R_2} = \frac{40 \text{ V}}{20 \text{ } \Omega} = 2 \text{ A}$

e.  $P_2 = I_2^2 R_2 = (2 \text{ A})^2(20 \text{ } \Omega) = 80 \text{ W}$

**Mathcad Solution:** This example provides an excellent opportunity to practice our skills using Mathcad. As shown in Fig. 6.24, the known parameters and quantities of the network are entered first, followed by an equation for the unknown resistor  $R_3$ . Note that after the first division operator was selected, a left bracket was established (to be followed eventually by a right enclosure bracket) to tell the computer that the mathematical operations in the denominator must be carried out first before the division into 1. In addition, each individual division into 1 is separated by brackets to ensure that the division operation is performed before each quantity is added to the neighboring factor. Finally, keep in mind that the Mathcad bracket must encompass each individual expression of the denominator before you place the right bracket in place.

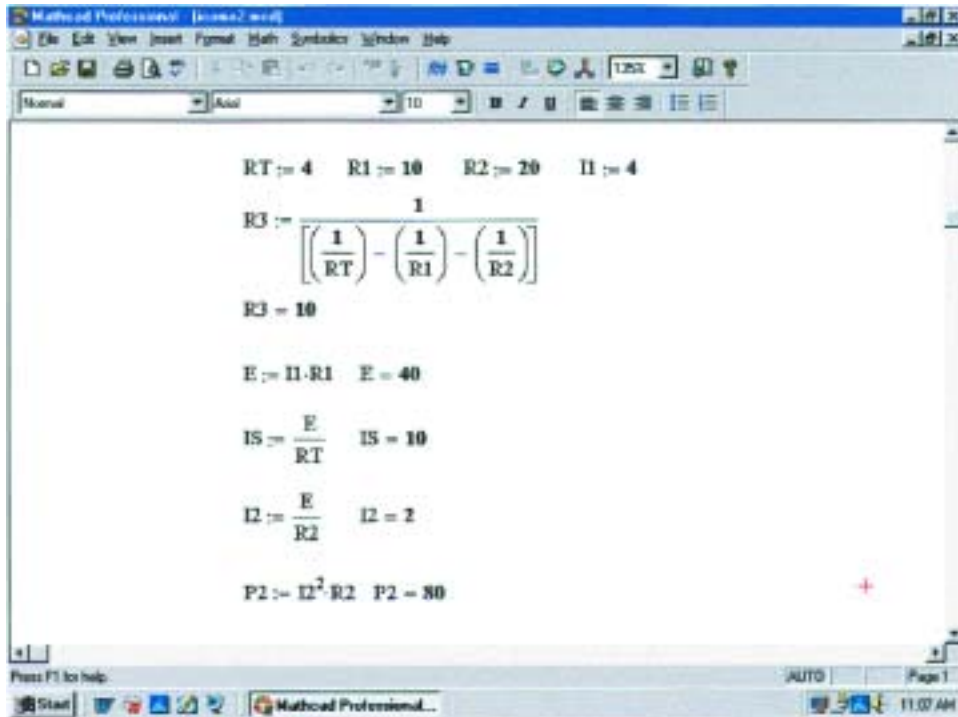


FIG. 6.24 Using Mathcad to confirm the results of Example 6.12.

In each case, the quantity of interest was entered below the defining equation to obtain the numerical result by selecting an equal sign. As expected, all the results match the longhand solution.

## 6.5 KIRCHHOFF'S CURRENT LAW

Kirchhoff's voltage law provides an important relationship among voltage levels around any closed loop of a network. We now consider **Kirchhoff's current law (KCL)**, which provides an equally important relationship among current levels at any junction.

**Kirchhoff's current law (KCL) states that the algebraic sum of the currents entering and leaving an area, system, or junction is zero.**

In other words,

*the sum of the currents entering an area, system, or junction must equal the sum of the currents leaving the area, system, or junction.*

In equation form:

$$\Sigma I_{\text{entering}} = \Sigma I_{\text{leaving}} \quad (6.8)$$

In Fig. 6.25, for instance, the shaded area can enclose an entire system, a complex network, or simply a junction of two or more paths. In each case the current entering must equal that leaving, as witnessed by the fact that

$$\begin{aligned} I_1 + I_4 &= I_2 + I_3 \\ 4 \text{ A} + 8 \text{ A} &= 2 \text{ A} + 10 \text{ A} \\ 12 \text{ A} &= 12 \text{ A} \end{aligned}$$

The most common application of the law will be at the junction of two or more paths of current flow, as shown in Fig. 6.26. For some students it is difficult initially to determine whether a current is entering or leaving a junction. One approach that may help is to picture yourself as standing on the junction and treating the path currents as arrows. If the arrow appears to be heading toward you, as is the case for  $I_1$  in Fig. 6.26, then it is entering the junction. If you see the tail of the arrow (from the junction) as it travels down its path away from you, it is leaving the junction, as is the case for  $I_2$  and  $I_3$  in Fig. 6.26.

Applying Kirchhoff's current law to the junction of Fig. 6.26:

$$\begin{aligned} \Sigma I_{\text{entering}} &= \Sigma I_{\text{leaving}} \\ 6 \text{ A} &= 2 \text{ A} + 4 \text{ A} \\ \underline{6 \text{ A}} &= \underline{6 \text{ A}} \quad (\text{checks}) \end{aligned}$$

In the next two examples, unknown currents can be determined by applying Kirchhoff's current law. Simply remember to place all current levels entering a junction to the left of the equals sign and the sum of all currents leaving a junction to the right of the equals sign. The water-in-the-pipe analogy is an excellent one for supporting and clarifying the preceding law. Quite obviously, the sum total of the water entering a junction must equal the total of the water leaving the exit pipes.

In technology the term **node** is commonly used to refer to a junction of two or more branches. Therefore, this term will be used frequently in the analyses that follow.

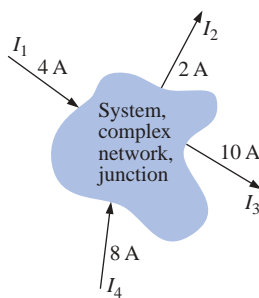


FIG. 6.25

Introducing Kirchhoff's current law.

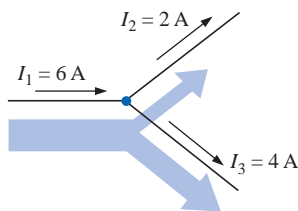
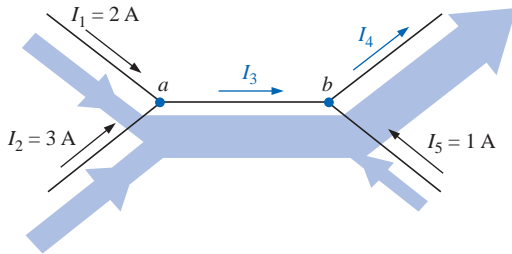


FIG. 6.26

Demonstrating Kirchhoff's current law.

**EXAMPLE 6.13** Determine the currents  $I_3$  and  $I_4$  of Fig. 6.27 using Kirchhoff's current law.

**Solution:** We must first work with junction  $a$  since the only unknown is  $I_3$ . At junction  $b$  there are two unknowns, and both cannot be determined from one application of the law.



**FIG. 6.27**  
Example 6.13.

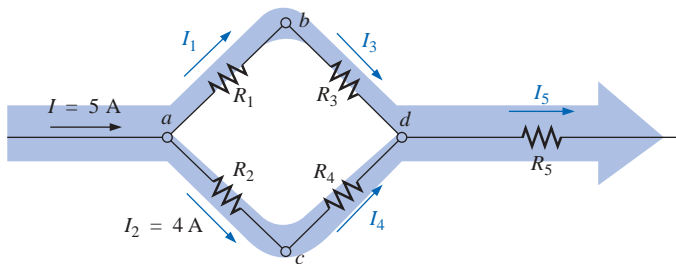
At  $a$ :

$$\begin{aligned} \Sigma I_{\text{entering}} &= \Sigma I_{\text{leaving}} \\ I_1 + I_2 &= I_3 \\ 2 \text{ A} + 3 \text{ A} &= I_3 \\ I_3 &= \mathbf{5 \text{ A}} \end{aligned}$$

At  $b$ :

$$\begin{aligned} \Sigma I_{\text{entering}} &= \Sigma I_{\text{leaving}} \\ I_3 + I_5 &= I_4 \\ 5 \text{ A} + 1 \text{ A} &= I_4 \\ I_4 &= \mathbf{6 \text{ A}} \end{aligned}$$

**EXAMPLE 6.14** Determine  $I_1$ ,  $I_3$ ,  $I_4$ , and  $I_5$  for the network of Fig. 6.28.



**FIG. 6.28**  
Example 6.14.

**Solution:** At  $a$ :

$$\begin{aligned} \Sigma I_{\text{entering}} &= \Sigma I_{\text{leaving}} \\ I &= I_1 + I_2 \\ 5 \text{ A} &= I_1 + 4 \text{ A} \end{aligned}$$

Subtracting 4 A from both sides gives

$$\begin{aligned} 5 \text{ A} - 4 \text{ A} &= I_1 + 4 \cancel{\text{A}} - 4 \cancel{\text{A}} \\ I_1 &= 5 \text{ A} - 4 \text{ A} = \mathbf{1 \text{ A}} \end{aligned}$$

At  $b$ :

$$\begin{aligned}\Sigma I_{\text{entering}} &= \Sigma I_{\text{leaving}} \\ I_1 &= I_3 = 1 \text{ A}\end{aligned}$$

as it should, since  $R_1$  and  $R_3$  are in series and the current is the same in series elements.

At  $c$ :

$$I_2 = I_4 = 4 \text{ A}$$

for the same reasons given for junction  $b$ .

At  $d$ :

$$\begin{aligned}\Sigma I_{\text{entering}} &= \Sigma I_{\text{leaving}} \\ I_3 + I_4 &= I_5 \\ 1 \text{ A} + 4 \text{ A} &= I_5 \\ I_5 &= 5 \text{ A}\end{aligned}$$

If we enclose the entire network, we find that the current entering is  $I = 5 \text{ A}$ ; the net current leaving from the far right is  $I_5 = 5 \text{ A}$ . The two must be equal since the net current entering any system must equal that leaving.

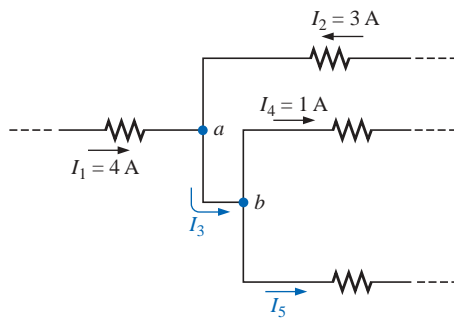


FIG. 6.29  
Example 6.15.

**EXAMPLE 6.15** Determine the currents  $I_3$  and  $I_5$  of Fig. 6.29 through applications of Kirchhoff's current law.

**Solution:** Note that since node  $b$  has two unknown quantities and node  $a$  has only one, we must first apply Kirchhoff's current law to node  $a$ . The result can then be applied to node  $b$ .

For node  $a$ ,

$$\begin{aligned}I_1 + I_2 &= I_3 \\ 4 \text{ A} + 3 \text{ A} &= I_3\end{aligned}$$

and

$$I_3 = 7 \text{ A}$$

For node  $b$ ,

$$\begin{aligned}I_3 &= I_4 + I_5 \\ 7 \text{ A} &= 1 \text{ A} + I_5\end{aligned}$$

and

$$I_5 = 7 \text{ A} - 1 \text{ A} = 6 \text{ A}$$

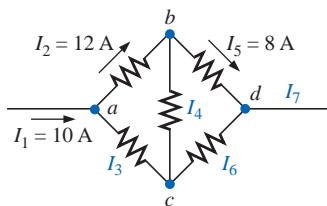


FIG. 6.30  
Example 6.16.

**EXAMPLE 6.16** Find the magnitude and direction of the currents  $I_3$ ,  $I_4$ ,  $I_6$ , and  $I_7$  for the network of Fig. 6.30. Even though the elements are not in series or parallel, Kirchhoff's current law can be applied to determine all the unknown currents.

**Solution:** Considering the overall system, we know that the current entering must equal that leaving. Therefore,

$$I_7 = I_1 = 10 \text{ A}$$

Since 10 A are entering node  $a$  and 12 A are leaving,  $I_3$  must be supplying current to the node.

Applying Kirchhoff's current law at node  $a$ ,

$$\begin{aligned}I_1 + I_3 &= I_2 \\ 10 \text{ A} + I_3 &= 12 \text{ A}\end{aligned}$$

and

$$I_3 = 12 \text{ A} - 10 \text{ A} = 2 \text{ A}$$

At node  $b$ , since 12 A are entering and 8 A are leaving,  $I_4$  must be leaving. Therefore,

$$I_2 = I_4 + I_5$$

$$12 \text{ A} = I_4 + 8 \text{ A}$$

and

$$I_4 = 12 \text{ A} - 8 \text{ A} = 4 \text{ A}$$

At node *c*,  $I_3$  is leaving at 2 A and  $I_4$  is entering at 4 A, requiring that  $I_6$  be leaving. Applying Kirchhoff's current law at node *c*,

$$I_4 = I_3 + I_6$$

$$4 \text{ A} = 2 \text{ A} + I_6$$

and

$$I_6 = 4 \text{ A} - 2 \text{ A} = 2 \text{ A}$$

As a check at node *d*,

$$I_5 + I_6 = I_7$$

$$8 \text{ A} + 2 \text{ A} = 10 \text{ A}$$

$$\mathbf{10 \text{ A} = 10 \text{ A}} \quad (\text{checks})$$

Looking back at Example 6.11, we find that the current entering the top node is 4.5 A and the current leaving the node is  $I_1 + I_2 = 3 \text{ A} + 1.5 \text{ A} = 4.5 \text{ A}$ . For Example 6.12, we have

$$I_s = I_1 + I_2 + I_3$$

$$10 \text{ A} = 4 \text{ A} + 2 \text{ A} + I_3$$

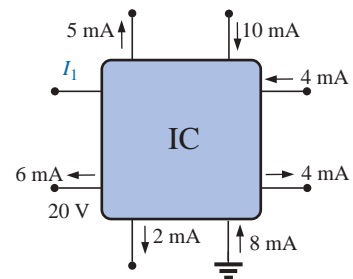
and

$$I_3 = 10 \text{ A} - 6 \text{ A} = 4 \text{ A}$$

The application of Kirchhoff's current law is not limited to networks where all the internal connections are known or visible. For instance, all the currents of the integrated circuit of Fig. 6.31 are known except  $I_1$ . By treating the system as a single node, we can apply Kirchhoff's current law using the following values to ensure an accurate listing of all known quantities:

$I_i$	$I_o$
10 mA	5 mA
4 mA	4 mA
<u>8 mA</u>	2 mA
22 mA	<u>6 mA</u>
	17 mA

Noting the total input current versus that leaving clearly reveals that  $I_1$  is a current of  $22 \text{ mA} - 17 \text{ mA} = 5 \text{ mA}$  leaving the system.



**FIG. 6.31**  
Integrated circuit.

## 6.6 CURRENT DIVIDER RULE

As the name suggests, the **current divider rule (CDR)** will determine how the current entering a set of parallel branches will split between the elements.

*For two parallel elements of equal value, the current will divide equally.*

*For parallel elements with different values, the smaller the resistance, the greater the share of input current.*

*For parallel elements of different values, the current will split with a ratio equal to the inverse of their resistor values.*

For example, if one of two parallel resistors is twice the other, then the current through the larger resistor will be half the other.

In Fig. 6.32, since  $I_1$  is 1 mA and  $R_1$  is six times  $R_3$ , the current through  $R_3$  must be 6 mA (without making any other calculations including the total current or the actual resistance levels). For  $R_2$  the current must be 2 mA since  $R_1$  is twice  $R_2$ . The total current must then be the sum of  $I_1$ ,  $I_2$ , and  $I_3$ , or 9 mA. In total, therefore, knowing only the current through  $R_1$ , we were able to find all the other currents of the configuration without knowing anything more about the network.

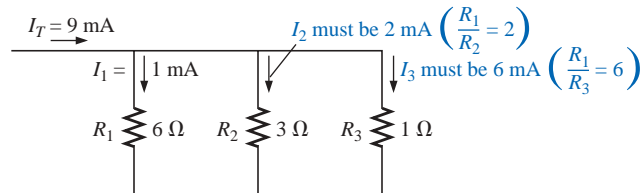


FIG. 6.32

Demonstrating how current will divide between unequal resistors.

For networks in which only the resistor values are given along with the input current, the current divider rule should be applied to determine the various branch currents. It can be derived using the network of Fig. 6.33.

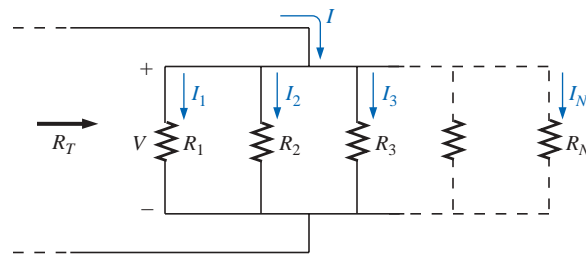


FIG. 6.33

Deriving the current divider rule.

The input current  $I$  equals  $V/R_T$ , where  $R_T$  is the total resistance of the parallel branches. Substituting  $V = I_x R_x$  into the above equation, where  $I_x$  refers to the current through a parallel branch of resistance  $R_x$ , we have

$$I = \frac{V}{R_T} = \frac{I_x R_x}{R_T}$$

and

$$I_x = \frac{R_T}{R_x} I \quad (6.9)$$

which is the general form for the current divider rule. In words, the current through any parallel branch is equal to the product of the *total* resistance of the parallel branches and the input current divided by the resistance of the branch through which the current is to be determined.

For the current  $I_1$ ,

$$I_1 = \frac{R_T}{R_1} I$$

and for  $I_2$ ,

$$I_2 = \frac{R_T}{R_2} I$$

and so on.



For the particular case of *two parallel resistors*, as shown in Fig. 6.34,

$$R_T = \frac{R_1 R_2}{R_1 + R_2}$$

and

$$I_1 = \frac{R_T I}{R_1} = \frac{R_1 R_2}{R_1 + R_2} \frac{I}{R_1}$$

and

$$I_1 = \frac{R_2 I}{R_1 + R_2}$$

Note difference in subscripts.

(6.10)

Similarly for  $I_2$ ,

$$I_2 = \frac{R_1 I}{R_1 + R_2}$$

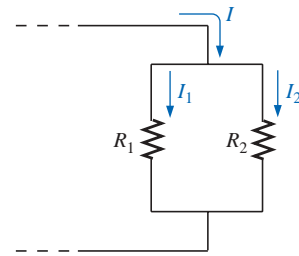
(6.11)

In words, for two parallel branches, the current through either branch is equal to the product of the *other* parallel resistor and the input current divided by the *sum* (not the total parallel resistance) of the two parallel resistances.

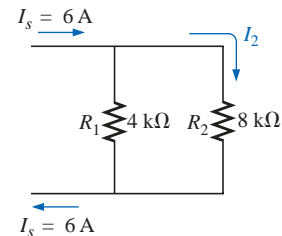
**EXAMPLE 6.17** Determine the current  $I_2$  for the network of Fig. 6.35 using the current divider rule.

**Solution:**

$$\begin{aligned} I_2 &= \frac{R_1 I_s}{R_1 + R_2} = \frac{(4 \text{ k}\Omega)(6 \text{ A})}{4 \text{ k}\Omega + 8 \text{ k}\Omega} = \frac{4}{12}(6 \text{ A}) = \frac{1}{3}(6 \text{ A}) \\ &= 2 \text{ A} \end{aligned}$$

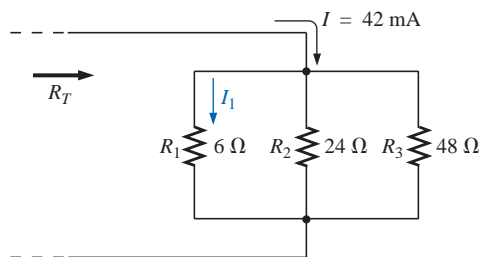


**FIG. 6.34**  
Developing an equation for current division between two parallel resistors.



**FIG. 6.35**  
Example 6.17.

**EXAMPLE 6.18** Find the current  $I_1$  for the network of Fig. 6.36.



**FIG. 6.36**  
Example 6.18

**Solution:** There are two options for solving this problem. The first is to use Eq. (6.9) as follows:

$$\begin{aligned} \frac{1}{R_T} &= \frac{1}{6 \Omega} + \frac{1}{24 \Omega} + \frac{1}{48 \Omega} = 0.1667 \text{ S} + 0.0417 \text{ S} + 0.0208 \text{ S} \\ &= 0.2292 \text{ S} \end{aligned}$$

and 
$$R_T = \frac{1}{0.2292 \text{ S}} = 4.363 \Omega$$

with 
$$I_1 = \frac{R_T}{R_1} I = \frac{4.363 \Omega}{6 \Omega} (42 \text{ mA}) = \mathbf{30.54 \text{ mA}}$$

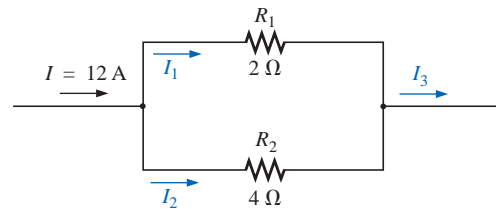
The second option is to apply Eq. (6.10) once after combining  $R_2$  and  $R_3$  as follows:

$$24 \Omega \parallel 48 \Omega = \frac{(24 \Omega)(48 \Omega)}{24 \Omega + 48 \Omega} = 16 \Omega$$

and 
$$I_1 = \frac{16 \Omega (42 \text{ mA})}{16 \Omega + 6 \Omega} = \mathbf{30.54 \text{ mA}}$$

Both options generated the same answer, leaving you with a choice for future calculations involving more than two parallel resistors.

**EXAMPLE 6.19** Determine the magnitude of the currents  $I_1$ ,  $I_2$ , and  $I_3$  for the network of Fig. 6.37.



**FIG. 6.37**  
Example 6.19.

**Solution:** By Eq. (6.10), the current divider rule,

$$I_1 = \frac{R_2 I}{R_1 + R_2} = \frac{(4 \Omega)(12 \text{ A})}{2 \Omega + 4 \Omega} = \mathbf{8 \text{ A}}$$

Applying Kirchhoff's current law,

$$I = I_1 + I_2$$

and 
$$I_2 = I - I_1 = 12 \text{ A} - 8 \text{ A} = \mathbf{4 \text{ A}}$$

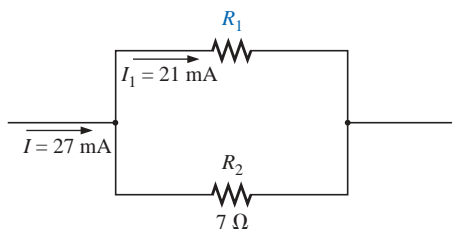
or, using the current divider rule again,

$$I_2 = \frac{R_1 I}{R_1 + R_2} = \frac{(2 \Omega)(12 \text{ A})}{2 \Omega + 4 \Omega} = \mathbf{4 \text{ A}}$$

The total current entering the parallel branches must equal that leaving. Therefore,

$$I_3 = I = \mathbf{12 \text{ A}}$$

or 
$$I_3 = I_1 + I_2 = 8 \text{ A} + 4 \text{ A} = \mathbf{12 \text{ A}}$$



**FIG. 6.38**  
Example 6.20.

**EXAMPLE 6.20** Determine the resistance  $R_1$  to effect the division of current in Fig. 6.38.

**Solution:** Applying the current divider rule,

$$I_1 = \frac{R_2 I}{R_1 + R_2}$$

and

$$\begin{aligned} (R_1 + R_2)I_1 &= R_2I \\ R_1I_1 + R_2I_1 &= R_2I \\ R_1I_1 &= R_2I - R_2I_1 \\ R_1 &= \frac{R_2(I - I_1)}{I_1} \end{aligned}$$

Substituting values:

$$\begin{aligned} R_1 &= \frac{7 \Omega(27 \text{ mA} - 21 \text{ mA})}{21 \text{ mA}} \\ &= 7 \Omega \left( \frac{6}{21} \right) = \frac{42 \Omega}{21} = 2 \Omega \end{aligned}$$

An alternative approach is

$$\begin{aligned} I_2 &= I - I_1 \quad (\text{Kirchhoff's current law}) \\ &= 27 \text{ mA} - 21 \text{ mA} = 6 \text{ mA} \\ V_2 &= I_2R_2 = (6 \text{ mA})(7 \Omega) = 42 \text{ mV} \\ V_1 &= I_1R_1 = V_2 = 42 \text{ mV} \end{aligned}$$

and

$$R_1 = \frac{V_1}{I_1} = \frac{42 \text{ mV}}{21 \text{ mA}} = 2 \Omega$$

From the examples just described, note the following:

**Current seeks the path of least resistance.**

That is,

1. More current passes through the smaller of two parallel resistors.
2. The current entering any number of parallel resistors divides into these resistors as the inverse ratio of their ohmic values. This relationship is depicted in Fig. 6.39.

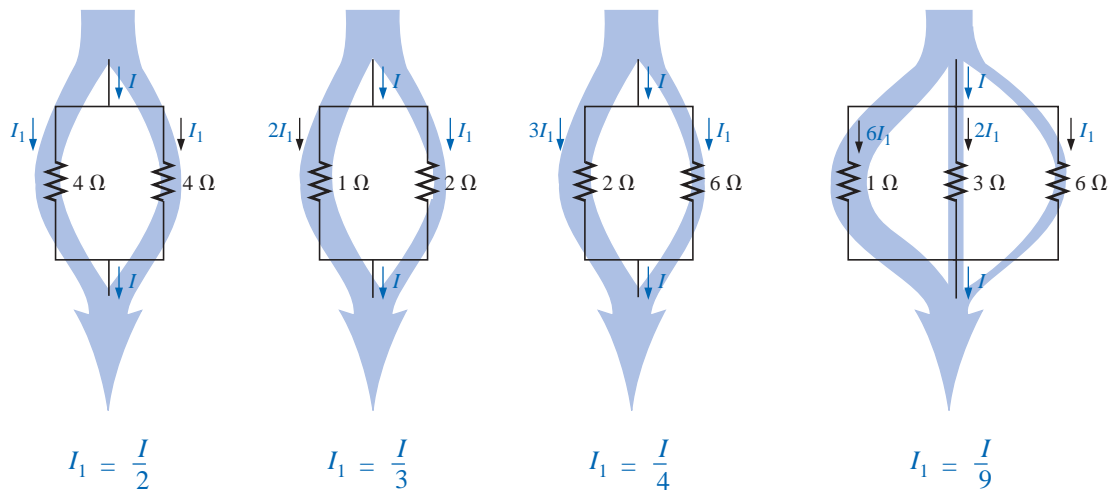
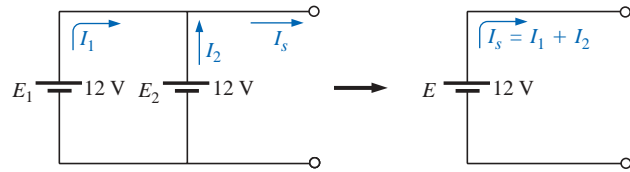


FIG. 6.39

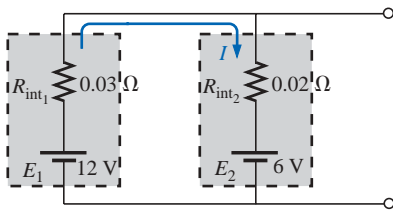
Current division through parallel branches.

### 6.7 VOLTAGE SOURCES IN PARALLEL

Voltage sources are placed in parallel as shown in Fig. 6.40 only if they have the same voltage rating. The primary reason for placing two or more batteries in parallel of the same terminal voltage would be to



**FIG. 6.40**  
Parallel voltage sources.



**FIG. 6.41**  
Parallel batteries of different terminal voltages.

increase the current rating (and, therefore, the power rating) of the source. As shown in Fig. 6.40, the current rating of the combination is determined by  $I_s = I_1 + I_2$  at the same terminal voltage. The resulting power rating is twice that available with one supply.

If two batteries of different terminal voltages were placed in parallel, both would be left ineffective or damaged because the terminal voltage of the larger battery would try to drop rapidly to that of the lower supply. Consider two lead-acid car batteries of different terminal voltage placed in parallel, as shown in Fig. 6.41.

The relatively small internal resistances of the batteries are the only current-limiting elements of the resulting series circuit. The current is

$$I = \frac{E_1 - E_2}{R_{int1} + R_{int2}} = \frac{12\text{ V} - 6\text{ V}}{0.03\ \Omega + 0.02\ \Omega} = \frac{6\text{ V}}{0.05\ \Omega} = \mathbf{120\text{ A}}$$

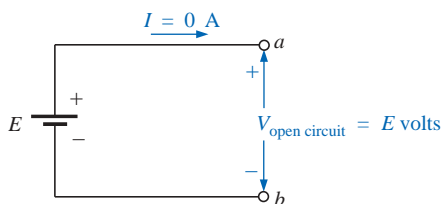
which far exceeds the continuous drain rating of the larger supply, resulting in a rapid discharge of  $E_1$  and a destructive impact on the smaller supply.

### 6.8 OPEN AND SHORT CIRCUITS

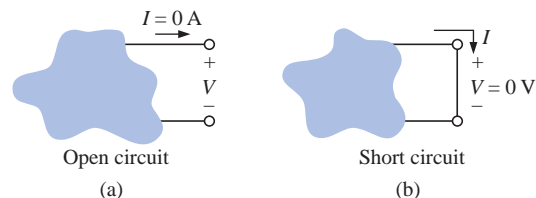
Open circuits and short circuits can often cause more confusion and difficulty in the analysis of a system than standard series or parallel configurations. This will become more obvious in the chapters to follow when we apply some of the methods and theorems.

An **open circuit** is simply two isolated terminals not connected by an element of any kind, as shown in Fig. 6.42(a). Since a path for conduction does not exist, the current associated with an open circuit must always be zero. The voltage across the open circuit, however, can be any value, as determined by the system it is connected to. In summary, therefore,

*an open circuit can have a potential difference (voltage) across its terminals, but the current is always zero amperes.*



**FIG. 6.43**  
Demonstrating the characteristics of an open circuit.



**FIG. 6.42**  
Two special network configurations.

In Fig. 6.43, an open circuit exists between terminals  $a$  and  $b$ . As shown in the figure, the voltage across the open-circuit terminals is the supply voltage, but the current is zero due to the absence of a complete circuit.

A **short circuit** is a very low resistance, direct connection between two terminals of a network, as shown in Fig. 6.42(b). The current through the short circuit can be any value, as determined by the system it is connected to, but the voltage across the short circuit will always be zero volts because the resistance of the short circuit is assumed to be essentially zero ohms and  $V = IR = I(0 \Omega) = 0 \text{ V}$ .

In summary, therefore,

*a short circuit can carry a current of a level determined by the external circuit, but the potential difference (voltage) across its terminals is always zero volts.*

In Fig. 6.44(a), the current through the  $2\text{-}\Omega$  resistor is  $5 \text{ A}$ . If a short circuit should develop across the  $2\text{-}\Omega$  resistor, the total resistance of the parallel combination of the  $2\text{-}\Omega$  resistor and the short (of essentially zero ohms) will be  $2 \Omega \parallel 0 \Omega = \frac{(2 \Omega)(0 \Omega)}{2 \Omega + 0 \Omega} = 0 \Omega$ , and the current will rise to very high levels, as determined by Ohm’s law:

$$I = \frac{E}{R} = \frac{10 \text{ V}}{0 \Omega} \rightarrow \infty \text{ A}$$

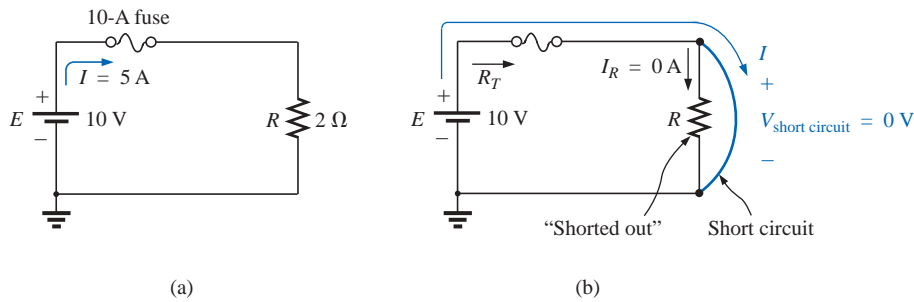


FIG. 6.44

Demonstrating the effect of a short circuit on current levels.

The effect of the  $2\text{-}\Omega$  resistor has effectively been “shorted out” by the low-resistance connection. The maximum current is now limited only by the circuit breaker or fuse in series with the source.

For the layperson, the terminology *short circuit* or *open circuit* is usually associated with dire situations such as power loss, smoke, or fire. However, in network analysis both can play an integral role in determining specific parameters about a system. Most often, however, if a short-circuit condition is to be established, it is accomplished with a *jumper*—a lead of negligible resistance to be connected between the points of interest. Establishing an open circuit simply requires making sure that the terminals of interest are isolated from each other.

**EXAMPLE 6.21** Determine the voltage  $V_{ab}$  for the network of Fig. 6.45.

**Solution:** The open circuit requires that  $I$  be zero amperes. The voltage drop across both resistors is therefore zero volts since  $V = IR = (0)R = 0 \text{ V}$ . Applying Kirchhoff’s voltage law around the closed loop,

$$V_{ab} = E = 20 \text{ V}$$

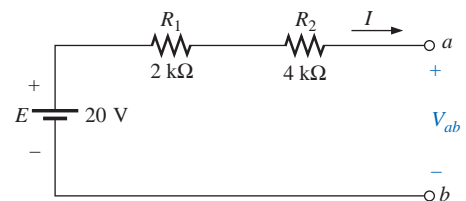
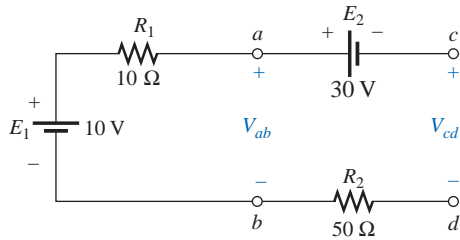
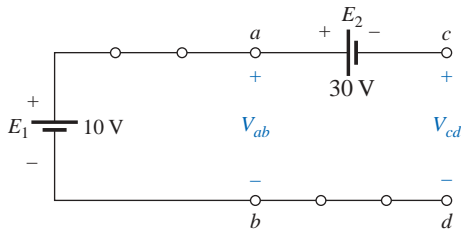


FIG. 6.45

Example 6.21.



**FIG. 6.46**  
Example 6.22.



**FIG. 6.47**  
Circuit of Fig. 6.46 redrawn.

**EXAMPLE 6.22** Determine the voltages  $V_{ab}$  and  $V_{cd}$  for the network of Fig. 6.46.

**Solution:** The current through the system is zero amperes due to the open circuit, resulting in a 0-V drop across each resistor. Both resistors can therefore be replaced by short circuits, as shown in Fig. 6.47. The voltage  $V_{ab}$  is then directly across the 10-V battery, and

$$V_{ab} = E_1 = 10 \text{ V}$$

The voltage  $V_{cd}$  requires an application of Kirchhoff's voltage law:

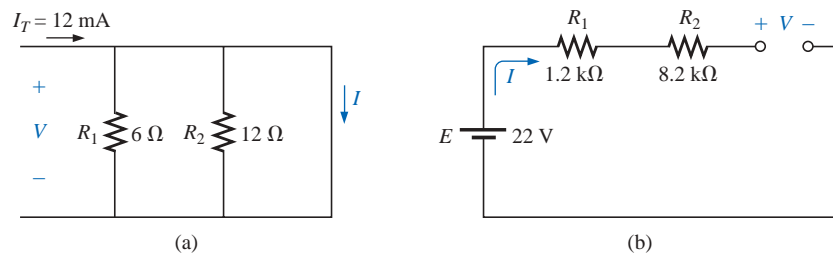
$$+E_1 - E_2 - V_{cd} = 0$$

or

$$V_{cd} = E_1 - E_2 = 10 \text{ V} - 30 \text{ V} = -20 \text{ V}$$

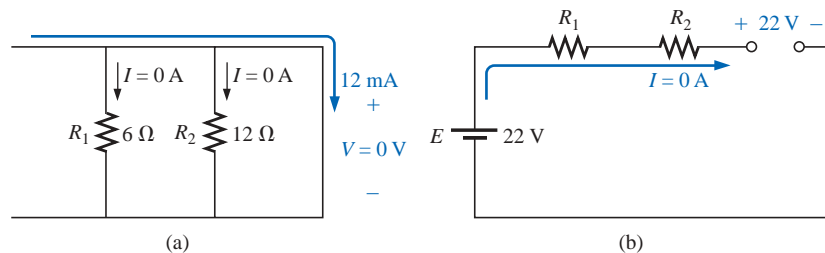
The negative sign in the solution simply indicates that the actual voltage  $V_{cd}$  has the opposite polarity of that appearing in Fig. 6.46.

**EXAMPLE 6.23** Determine the unknown voltage and current for each network of Fig. 6.48.



**FIG. 6.48**  
Example 6.23.

**Solution:** For the network of Fig. 6.48(a), the current  $I_T$  will take the path of least resistance, and, since the short-circuit condition at the end of the network is the least-resistance path, all the current will pass through the short circuit. This conclusion can be verified using Eq. (6.9). The voltage across the network is the same as that across the short circuit and will be zero volts, as shown in Fig. 6.49(a).



**FIG. 6.49**  
Solutions to Example 6.23.

For the network of Fig. 6.48(b), the open-circuit condition requires that the current be zero amperes. The voltage drops across the resistors

must therefore be zero volts, as determined by Ohm's law [ $V_R = IR = (0)R = 0 \text{ V}$ ], with the resistors simply acting as a connection from the supply to the open circuit. The result is that the open-circuit voltage will be  $E = 22 \text{ V}$ , as shown in Fig. 6.49(b).

**EXAMPLE 6.24** Calculate the current  $I$  and the voltage  $V$  for the network of Fig. 6.50.

**Solution:** The  $10\text{-k}\Omega$  resistor has been effectively shorted out by the jumper, resulting in the equivalent network of Fig. 6.51. Using Ohm's law,

$$I = \frac{E}{R_1} = \frac{18 \text{ V}}{5 \text{ k}\Omega} = 3.6 \text{ mA}$$

and  $V = E = 18 \text{ V}$

**EXAMPLE 6.25** Determine  $V$  and  $I$  for the network of Fig. 6.52 if the resistor  $R_2$  is shorted out.

**Solution:** The redrawn network appears in Fig. 6.53. The current through the  $3\text{-}\Omega$  resistor is zero due to the open circuit, causing all the current  $I$  to pass through the jumper. Since  $V_{3\Omega} = IR = (0)R = 0 \text{ V}$ , the voltage  $V$  is directly across the short, and

$$V = 0 \text{ V}$$

with  $I = \frac{E}{R_1} = \frac{6 \text{ V}}{2 \Omega} = 3 \text{ A}$

### 6.9 VOLTMETERS: LOADING EFFECT

In Chapters 2 and 5, it was noted that voltmeters are always placed across an element to measure the potential difference. We now realize that this connection is synonymous with placing the voltmeter in parallel with the element. The insertion of a meter in parallel with a resistor results in a combination of parallel resistors as shown in Fig. 6.54. Since the resistance of two parallel branches is always less than the smaller parallel resistance, the resistance of the voltmeter should be as large as possible (ideally infinite). In Fig. 6.54, a DMM with an internal resistance of  $11 \text{ M}\Omega$  is measuring the voltage across a  $10\text{-k}\Omega$  resistor. The total resistance of the combination is

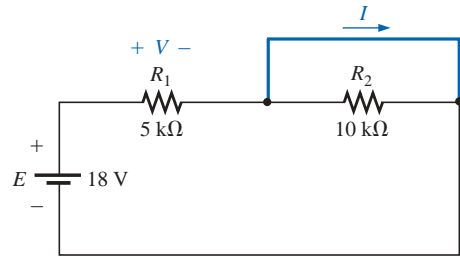
$$R_T = 10 \text{ k}\Omega \parallel 11 \text{ M}\Omega = \frac{(10^4 \Omega)(11 \times 10^6 \Omega)}{10^4 \Omega + (11 \times 10^6 \Omega)} = 9.99 \text{ k}\Omega$$

and we find that the network is essentially undisturbed. However, if we use a VOM with an internal resistance of  $50 \text{ k}\Omega$  on the  $2.5\text{-V}$  scale, the parallel resistance is

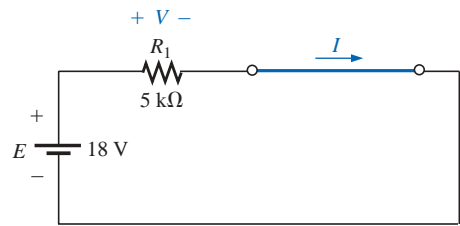
$$R_T = 10 \text{ k}\Omega \parallel 50 \text{ k}\Omega = \frac{(10^4 \Omega)(50 \times 10^3 \Omega)}{10^4 \Omega + (50 \times 10^3 \Omega)} = 8.33 \text{ k}\Omega$$

and the behavior of the network will be altered somewhat since the  $10\text{-k}\Omega$  resistor will now appear to be  $8.33 \text{ k}\Omega$  to the rest of the network.

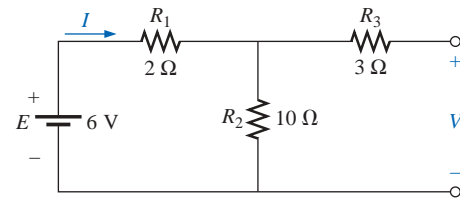
The loading of a network by the insertion of meters is not to be taken lightly, especially in research efforts where accuracy is a primary consideration. It is good practice always to check the meter resistance level



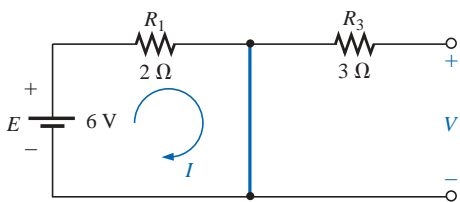
**FIG. 6.50**  
Example 6.24.



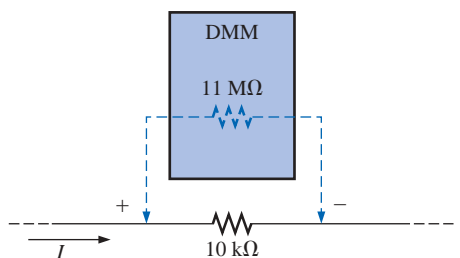
**FIG. 6.51**  
Network of Fig. 6.50 redrawn.



**FIG. 6.52**  
Example 6.25.



**FIG. 6.53**  
Network of Fig. 6.52 with  $R_2$  replaced by a jumper.



**FIG. 6.54**  
Voltmeter loading.

against the resistive elements of the network before making measurements. A factor of 10 between resistance levels will usually provide fairly accurate meter readings for a wide range of applications.

Most DMMs have internal resistance levels in excess of  $10\text{ M}\Omega$  on all voltage scales, while the internal resistance of VOMs is sensitive to the chosen scale. To determine the resistance of each scale setting of a VOM in the voltmeter mode, simply multiply the maximum voltage of the scale setting by the **ohm/volt ( $\Omega/\text{V}$ ) rating** of the meter, normally found at the bottom of the face of the meter.

For a typical ohm/volt rating of 20,000, the 2.5-V scale would have an internal resistance of

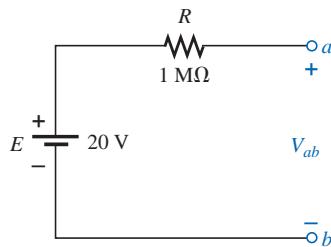
$$(2.5\text{ V})(20,000\ \Omega/\text{V}) = 50\text{ k}\Omega$$

whereas for the 100-V scale, it would be

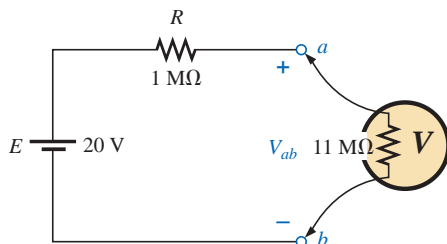
$$(100\text{ V})(20,000\ \Omega/\text{V}) = 2\text{ M}\Omega$$

and for the 250-V scale,

$$(250\text{ V})(20,000\ \Omega/\text{V}) = 5\text{ M}\Omega$$



**FIG. 6.55**  
Example 6.26.



**FIG. 6.56**  
Applying a DMM to the circuit of Fig. 6.55.

**EXAMPLE 6.26** For the relatively simple network of Fig. 6.55:

- What is the open-circuit voltage  $V_{ab}$ ?
- What will a DMM indicate if it has an internal resistance of  $11\text{ M}\Omega$ ? Compare your answer to the results of part (a).
- Repeat part (b) for a VOM with an  $\Omega/\text{V}$  rating of 20,000 on the 100-V scale.

**Solutions:**

- $V_{ab} = 20\text{ V}$
- The meter will complete the circuit as shown in Fig. 6.56. Using the voltage divider rule,

$$V_{ab} = \frac{11\text{ M}\Omega(20\text{ V})}{11\text{ M}\Omega + 1\text{ M}\Omega} = 18.33\text{ V}$$

- For the VOM, the internal resistance of the meter is

$$R_m = 100\text{ V}(20,000\ \Omega/\text{V}) = 2\text{ M}\Omega$$

and

$$V_{ab} = \frac{2\text{ M}\Omega(20\text{ V})}{2\text{ M}\Omega + 1\text{ M}\Omega} = 13.33\text{ V}$$

revealing the need to consider carefully the internal resistance of the meter in some instances.

## Measurement Techniques

For components in series, the placement of ammeters and voltmeters was quite straightforward if a few simple rules were followed. For parallel circuits, however, some of the measurements can require a little extra care. For any configuration keep in mind that all voltage measurements can be made without disturbing the network at all. For ammeters, however, the branch in which the current is to be measured must be opened and the meter inserted.

Since the voltage is the same across parallel elements, only one voltmeter will be required as shown in Fig. 6.57. It is a two-point measurement, with the negative or black lead connected to the point of lower potential and the positive or red lead to the point of higher potential to



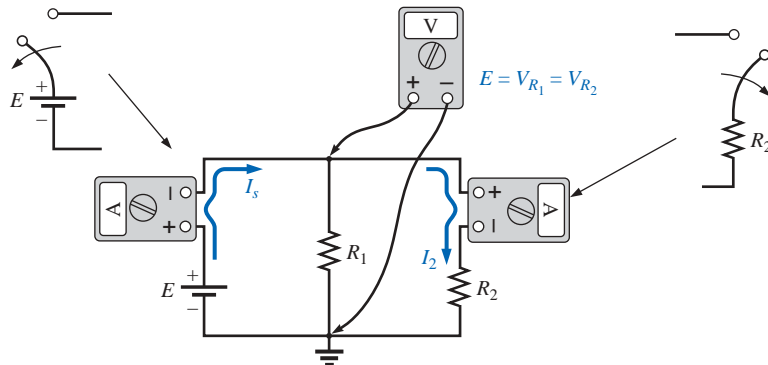


FIG. 6.57

Setting up meters to measure the voltage and currents of a parallel network.

ensure a positive reading. The current through the source can be determined by simply disconnecting the positive terminal of the supply from the network and inserting the ammeter as shown in Fig. 6.57. Note that it is set up to have conventional current enter the positive terminal of the meter and leave the negative terminal. The current through  $R_2$  can also be determined quite easily by simply disconnecting the lead from the top of the resistor and inserting the ammeter. Again, it is set up for conventional current to enter the positive terminal for an up-scale reading.

Measuring the current through resistor  $R_1$  requires a bit more care. It may not initially appear to be that complicated, but the laboratory experience is a clear indication that this measurement can cause some difficulties. In general, it simply requires that the connection to the top of resistor  $R_1$  be removed as shown in Fig. 6.58(a) to create an open circuit in series with resistor  $R_1$ . Then the meter is inserted as shown in Fig. 6.58(b), and the correct current reading will be obtained.

As a check against any of the ammeter readings, keep in mind that  $I_s = I_1 + I_2$ , so that if  $I_1 = I_s$  or  $I_1 = I_2$  (for a network with different values of  $R_1$  and  $R_2$ ), you should check your readings. Remember also that the ammeter reading will be higher for the smaller resistor of two parallel resistors.

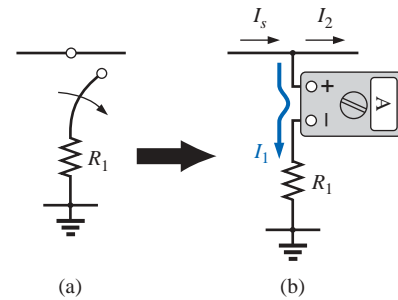


FIG. 6.58

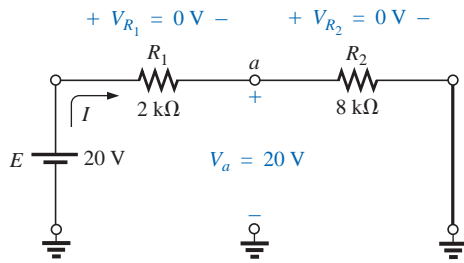
Measuring current  $I_1$  for the network of Fig. 6.57.

### 6.10 TROUBLESHOOTING TECHNIQUES

The art of *troubleshooting* is not limited solely to electrical or electronic systems. In the broad sense,

*troubleshooting is a process by which acquired knowledge and experience are employed to localize a problem and offer or implement a solution.*

There are many reasons why the simplest electrical circuit does not operate correctly. A connection may be open; the measuring instruments may need calibration; the power supply may not be on or may have been connected incorrectly to the circuit; an element may not be performing correctly due to earlier damage or poor manufacturing; a fuse may have blown; and so on. Unfortunately, a defined sequence of steps does not exist for identifying the wide range of problems that can surface in an electrical system. It is only through experience and a clear understanding of the basic laws of electric circuits that one can expect to become proficient at quickly locating the cause of an erroneous output.



**FIG. 6.59**  
A malfunctioning network.

It should be fairly obvious, however, that the first step in checking a network or identifying a problem area is to have some idea of the expected voltage and current levels. For instance, the circuit of Fig. 6.59 should have a current in the low milliamperage range, with the majority of the supply voltage across the 8-k $\Omega$  resistor. However, as indicated in Fig. 6.59,  $V_{R_1} = V_{R_2} = 0\text{ V}$  and  $V_a = 20\text{ V}$ . Since  $V = IR$ , the results immediately suggest that  $I = 0\text{ A}$  and an open circuit exists in the circuit. The fact that  $V_a = 20\text{ V}$  immediately tells us that the connections are true from the ground of the supply to point  $a$ . The open circuit must therefore exist between  $R_1$  and  $R_2$  or at the ground connection of  $R_2$ . An open circuit at either point will result in  $I = 0\text{ A}$  and the readings obtained previously. Keep in mind that, even though  $I = 0\text{ A}$ ,  $R_1$  does form a connection between the supply and point  $a$ . That is, if  $I = 0\text{ A}$ ,  $V_{R_1} = IR_1 = (0)R_1 = 0\text{ V}$ , as obtained for a short circuit.

In Fig. 6.59, if  $V_{R_1} \cong 20\text{ V}$  and  $V_{R_2}$  is quite small ( $\cong 0.08\text{ V}$ ), it first suggests that the circuit is complete, a current does exist, and a problem surrounds the resistor  $R_2$ .  $R_2$  is not shorted out since such a condition would result in  $V_{R_2} = 0\text{ V}$ . A careful check of the inserted resistor reveals that an 8- $\Omega$  resistor was employed rather than the 8-k $\Omega$  resistor called for—an incorrect reading of the color code. Perhaps in the future an ohmmeter should be used to check a resistor to validate the color-code reading or to ensure that its value is still in the prescribed range set by the color code.

There will be occasions when frustration may develop. You've checked all the elements, and all the connections appear tight. The supply is on and set at the proper level; the meters appear to be functioning correctly. In situations such as this, experience becomes a key factor. Perhaps you can recall when a recent check of a resistor revealed that the internal connection (not externally visible) was a “make or break” situation or that the resistor was damaged earlier by excessive current levels, so its actual resistance was much lower than called for by the color code. Recheck the supply! Perhaps the terminal voltage was set correctly, but the current control knob was left in the zero or minimum position. Is the ground connection stable? The questions that arise may seem endless. However, take heart in the fact that with experience comes an ability to localize problems more rapidly. Of course, the more complicated the system, the longer the list of possibilities, but it is often possible to identify a particular area of the system that is behaving improperly before checking individual elements.

## 6.11 APPLICATIONS

### Car System

In Chapter 3, we examined the role of a potentiometer in controlling the light intensity of the panel of a typical automobile. We will now take our analysis a step further and investigate how a number of other elements of the car are connected to the 12-V dc supply.

First, it must be understood that the entire electrical system of a car is run as a *dc system*. Although the generator will produce a varying ac signal, rectification will convert it to one having an average dc level for charging the battery. In particular, note the filter capacitor (Chapter 10) in the alternator branch of Fig. 6.60 to smooth out the rectified ac wave-

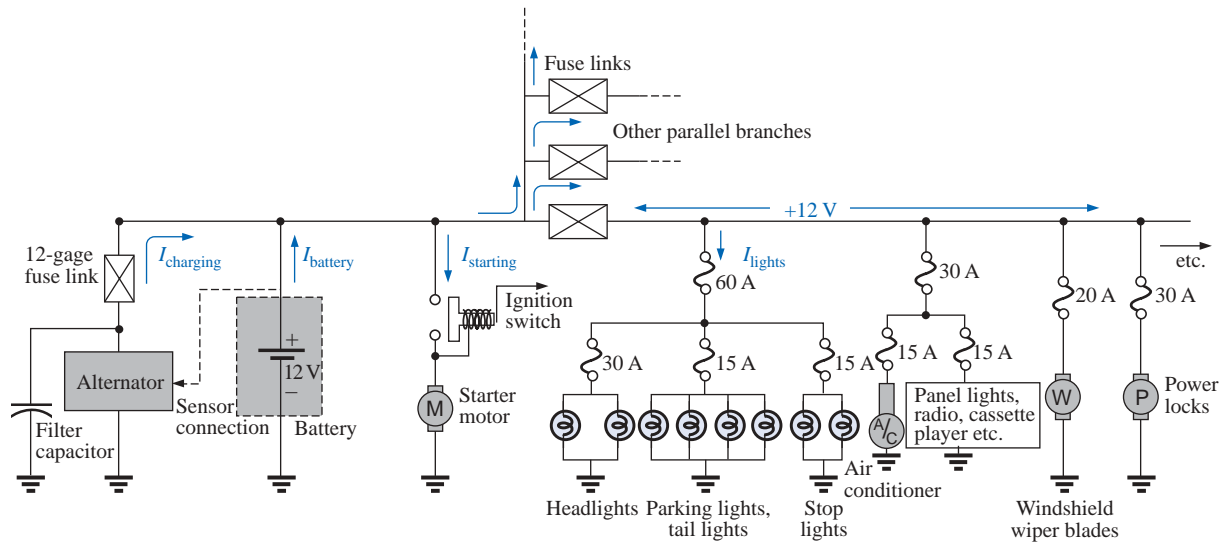


FIG. 6.60

*Expanded view of an automobile's electrical system.*

form and to provide an improved dc supply. The charged battery must therefore provide the required direct current for the entire electrical system of the car. Thus, the power demand on the battery at any instant is the product of the terminal voltage and the current drain of the total load of every operating system of the car. This certainly places an enormous burden on the battery and its internal chemical reaction and warrants all the battery care we can provide.

Since the electrical system of a car is essentially a parallel system, the total current drain on the battery is the sum of the currents to all the parallel branches of the car connected directly to the battery. In Fig. 6.60 a few branches of the wiring diagram for a car have been sketched to provide some background information on basic wiring, current levels, and fuse configurations. Every automobile has fuse links and fuses, and some also have circuit breakers, to protect the various components of the car and to ensure that a dangerous fire situation does not develop. Except for a few branches that may have series elements, the operating voltage for most components of a car is the terminal voltage of the battery which we will designate as 12 V even though it will typically vary between 12 V and the charging level of 14.6 V. In other words, each component is connected to the battery at one end and to the ground or chassis of the car at the other end.

Referring to Fig. 6.60, we find that the alternator or charging branch of the system is connected directly across the battery to provide the charging current as indicated. Once the car is started, the rotor of the alternator will turn, generating an ac varying voltage which will then pass through a rectifier network and filter to provide the dc charging voltage for the battery. Charging will occur only when the sensor, connected directly to the battery, signals that the terminal voltage of the battery is too low. Just to the right of the battery the starter branch was included to demonstrate that there is no fusing action between the battery and starter when the ignition switch is activated. The lack of fusing action is provided because enormous starting currents (hundreds of amperes) will flow through the starter to start a car that may not have

been used for days and/or that may have been sitting in a cold climate—and high friction occurs between components until the oil starts flowing. The starting level can vary so much that it would be difficult to find the right fuse level, and frequent high currents may damage the fuse link and cause a failure at expected levels of current. When the ignition switch is activated, the starting relay will complete the circuit between the battery and starter, and hopefully the car will start. If a car should fail to start, the first point of attack should be to check the connections at the battery, starting relay, and starter to be sure that they are not providing an unexpected open circuit due to vibration, corrosion, or moisture.

Once the car has started, the starting relay will open and the battery can turn its attention to the operating components of the car. Although the diagram of Fig. 6.60 does not display the switching mechanism, the entire electrical network of the car, except for the important external lights, is usually disengaged so that the full strength of the battery can be dedicated to the starting process. The lights are included for situations where turning the lights off, even for short periods of time, could create a dangerous situation. If the car is in a safe environment, it is best to leave the lights off at starting to save the battery an additional 30 A of drain. If the lights are on at starting, a dimming of the lights can be expected due to the starter drain which may exceed 500 A. Today, batteries are typically rated in cranking (starting) current rather than ampere-hours. Batteries rated with cold cranking ampere ratings between 700 A and 1000 A are typical today.

Separating the alternator from the battery and the battery from the numerous networks of the car are fuse links such as shown in Fig. 6.61(a). They are actually wires of specific gage designed to open at fairly high current levels of 100 A or more. They are included to protect against those situations where there is an unexpected current drawn from the many circuits it is connected to. That heavy drain can, of course, be from a short circuit in one of the branches, but in such cases the fuse in that branch will probably release. The fuse link is an additional protection for the line if the total current drawn by the parallel-connected branches begins to exceed safe levels. The fuses following the fuse link have the appearance shown in Fig. 6.61(b), where a gap between the legs of the fuse indicates a blown fuse. As shown in Fig. 6.60, the 60-A fuse (often called a *power distribution fuse*) for the lights is a second-tier fuse sensitive to the total drain from the three light circuits. Finally, the third fuse level is for the individual units of a

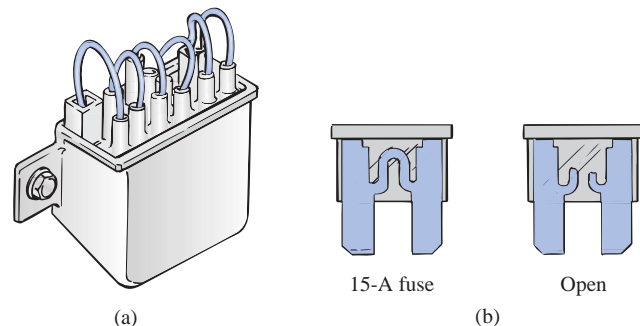


FIG. 6.61

Car fuses: (a) fuse link; (b) plug-in.

car such as the lights, air conditioner, and power locks. In each case, the fuse rating exceeds the normal load (current level) of the operating component, but the level of each fuse does give some indication of the demand to be expected under normal operating conditions. For instance, the headlights will typically draw more than 10 A, the tail lights more than 5 A, the air conditioner about 10 A (when the clutch engages), and the power windows 10 A to 20 A depending on how many are operated at once.

Some details for only one section of the total car network are provided in Fig. 6.60. In the same figure, additional parallel paths with their respective fuses have been provided to further reveal the parallel arrangement of all the circuits.

In all vehicles made in the United States and in some vehicles made in European countries, the return path to the battery through the ground connection is actually through the chassis of the car. That is, there is only one wire to each electrical load, with the other end simply grounded to the chassis. The return to the battery (chassis to negative terminal) is therefore a heavy-gage wire matching that connected to the positive terminal. In some European cars constructed of a mixture of materials such as metal, plastic, and rubber, the return path through the metallic chassis is lost, and two wires must be connected to each electrical load of the car.

## Parallel Computer Bus Connections

The internal construction (hardware) of large mainframe computers and full-size desk models is set up to accept a variety of adapter cards in the slots appearing in Fig. 6.62(a). The primary board (usually the largest), commonly called the *motherboard*, contains most of the functions required for full computer operation. Adapter cards are normally added to expand the memory, set up a network, add peripheral equipment, and so on. For instance, if you decide to add a modem to your computer, you can simply insert the modem card into the proper channel of Fig. 6.62(a). The bus connectors are connected in parallel with common connections to the power supply, address and data buses, control signals, ground, and so on. For instance, if the bottom connection of each bus connector is a ground connection, that ground connection carries through each bus connector and is immediately connected to any adapter card installed. Each card has a slot connector that will fit directly into the bus connector without the need for any soldering or construction. The pins of the adapter card are then designed to provide a path between the motherboard and its components to support the desired function. Note in Fig. 6.62(b), which is a back view of the region identified in Fig. 6.62(a), that if you follow the path of the second pin from the top on the far left, it will be connected to the same pin on the other three bus connectors.

Most small lap-top computers today have all the options already installed, thereby bypassing the need for bus connectors. Additional memory and other upgrades are added as direct inserts into the motherboard.

## House Wiring

In Chapter 4, the basic power levels of importance were discussed for various services to the home. We are now ready to take the next step and examine the actual connection of elements in the home.

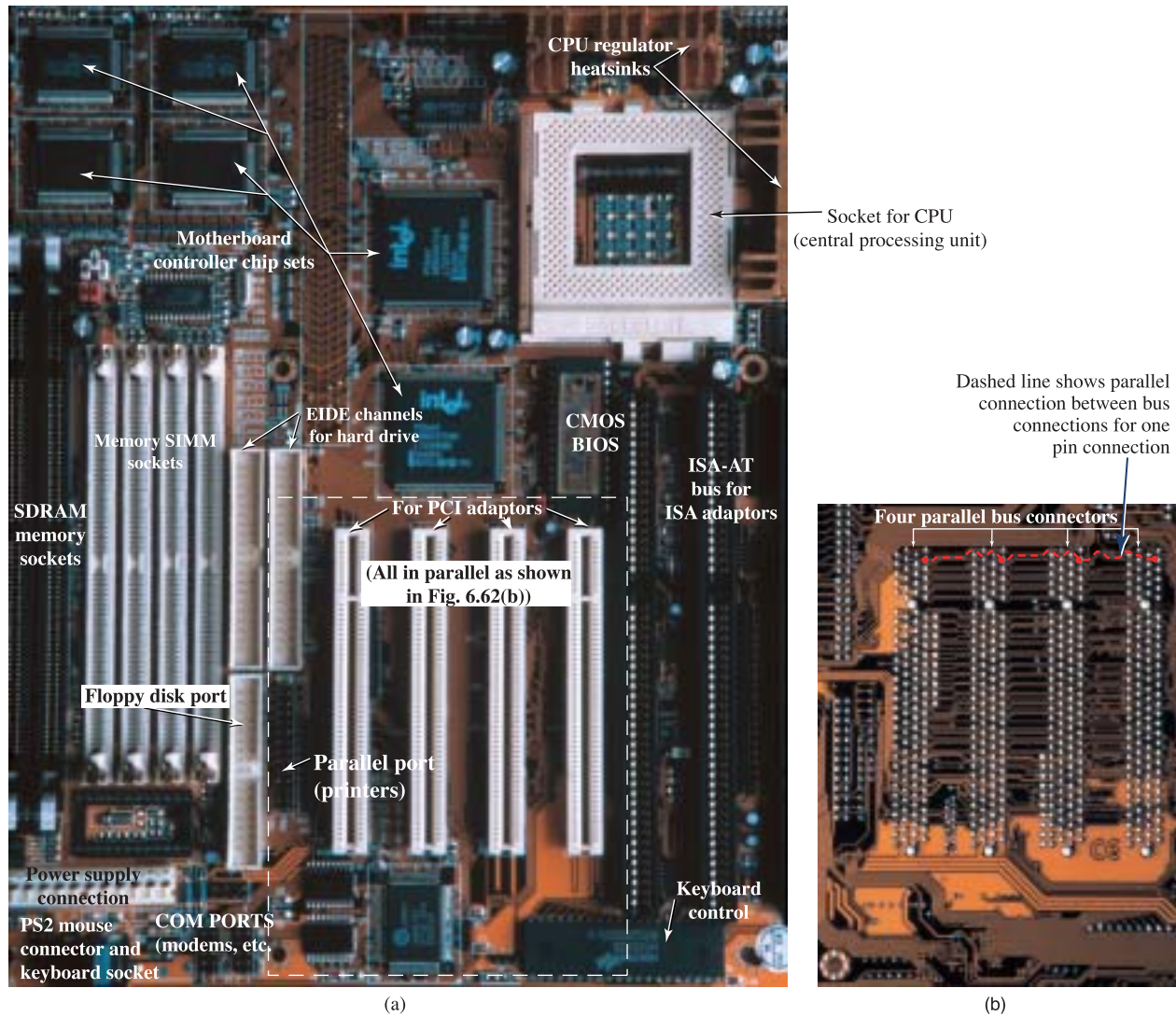


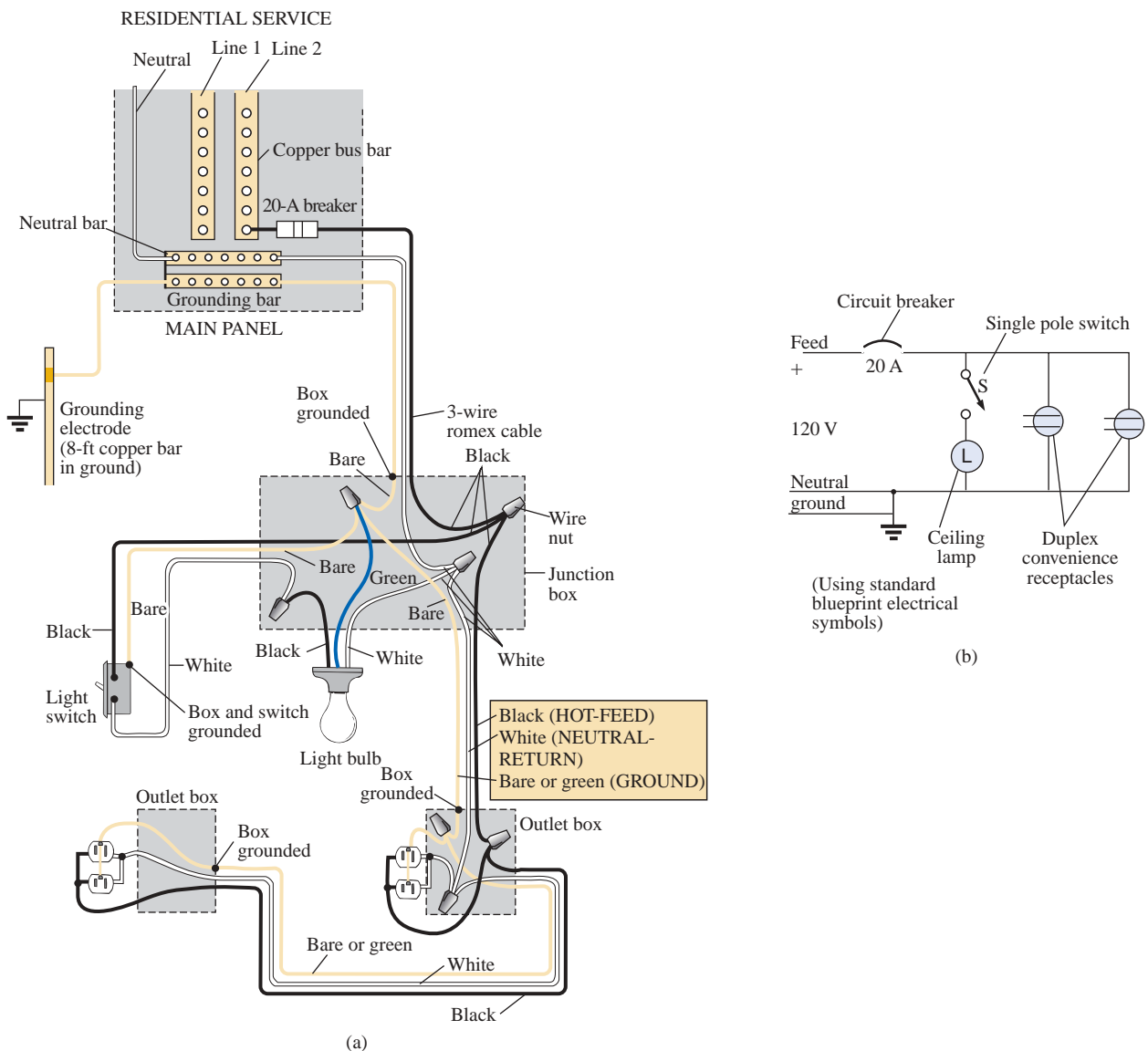
FIG. 6.62

(a) Motherboard for a desk-top computer; (b) showing the printed circuit board connections for the region indicated in part (a).

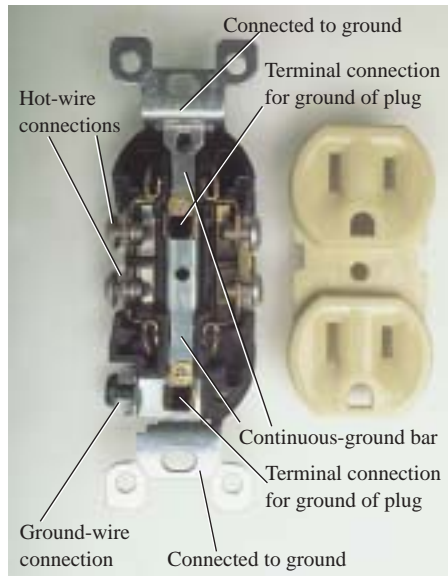
First, it is important to realize that except for some very special circumstances, the basic wiring is done in a parallel configuration. Each parallel branch, however, can have a combination of parallel and series elements. Every full branch of the circuit receives the full 120 V or 208 V, with the current determined by the applied load. Figure 6.63(a) provides the detailed wiring of a single circuit having a light bulb and two outlets. Figure 6.63(b) shows the schematic representation. First note that although each load is in parallel with the supply, switches are always connected in series with the load. The power will get to the lamp only when the switch is closed and the full 120 V appears across the bulb. The connection point for the two outlets is in the ceiling box holding the light bulb. Since a switch is not present, both outlets are always “hot” unless the circuit breaker in the main panel is opened. It is important that you understand this because you may be tempted to change the light fixture by simply turning off the wall switch. True, if you’re very

careful, you can work with one line at a time (being sure that you don't touch the other line at any time), but it is standard procedure to throw the circuit breaker on the panel whenever working on a circuit. Note in Fig. 6.63(a) that the *feed* wire (black) into the fixture from the panel is connected to the switch and both outlets at one point. It is not connected directly to the light fixture because that would put it on all the time. Power to the light fixture is made available through the switch. The continuous connection to the outlets from the panel ensures that the outlets are "hot" whenever the circuit breaker in the panel is on. Note also how the *return* wire (white) is connected directly to the light switch and outlets to provide a return for each component. There is no need for the white wire to go through the switch since an applied voltage is a two-point connection and the black wire is controlled by the switch.

Proper grounding of the system in total and of the individual loads is one of the most important facets in the installation of any system. There



**FIG. 6.63**  
Single phase of house wiring: (a) physical details; (b) schematic representation.

**FIG. 6.64**

*Continuous ground connection in a duplex outlet.*

is a tendency at times to be satisfied that the system is working and to pay less attention to proper grounding technique. Always keep in mind that a properly grounded system has a direct path to ground if an undesirable situation should develop. The absence of a direct ground will cause the system to determine its own path to ground, and you could be that path if you happened to touch the wrong wire, metal box, metal pipe, and so on. In Fig. 6.63(a), the connections for the ground wires have been included. For the romex (plastic-coated wire) used in Fig. 6.63(a), the ground wire is provided as a bare copper wire. Note that it is connected to the panel which in turn is directly connected to the grounded 8-ft copper rod. In addition, note that the ground connection is carried through the entire circuit, including the switch, light fixture, and outlets. It is one continuous connection. If the outlet box, switch box, and housing for the light fixture are made of a conductive material such as metal, the ground will be connected to each. If each is plastic, there is no need for the ground connection. However, the switch, both outlets, and the fixture itself are connected to ground. For the switch and outlets there is usually a green screw for the ground wire which is connected to the entire framework of the switch or outlet as shown in Fig. 6.64, including the ground connection of the outlet. For both the switch and the outlet, even the screw or screws used to hold the outside plate in place are grounded since they are screwed into the metal housing of the switch or outlet. When screwed into a metal box, the ground connection can be made by the screws that hold the switch or outlet in the box as shown in Figure 6.64. In any event, always pay strict attention to the grounding process whenever installing any electrical equipment. It is a facet of electrical installation that is often treated too lightly.

On the practical side, whenever hooking up a wire to a screw-type terminal, always wrap the wire around the screw in the clockwise manner so that when you tighten the screw, it will grab the wire and turn it in the same direction. An expanded view of a typical house-wiring arrangement will appear in Chapter 15.

## 6.12 COMPUTER ANALYSIS

### PSpice

**Parallel dc Networks** The computer analysis coverage for parallel dc circuits will be very similar to that of series dc circuits. However, in this case the voltage will be the same across all the parallel elements, and the current through each branch will change with the resistance value. The parallel network to be analyzed will have a wide range of resistor values to demonstrate the effect on the resulting current. The following is a list of abbreviations for any parameter of a network when using PSpice:

$$\begin{aligned}
 \mathbf{f} &= 10^{-15} \\
 \mathbf{p} &= 10^{-12} \\
 \mathbf{n} &= 10^{-9} \\
 \boldsymbol{\mu} &= 10^{-6} \\
 \mathbf{m} &= 10^{-3} \\
 \mathbf{k} &= 10^{+3} \\
 \mathbf{MEG} &= 10^{+6} \\
 \mathbf{G} &= 10^{+9} \\
 \mathbf{T} &= 10^{+12}
 \end{aligned}$$



In particular, note that **m** (or **M**) is used for “milli,” and **MEG** for “megohms.” Also, PSpice does not distinguish between upper- and lower-case units, but certain parameters typically use either the upper- or lower-case abbreviation as shown above.

Since the details of setting up a network and going through the simulation process were covered in detail in Sections 4.9 and 5.12 for dc circuits, the coverage here will be limited solely to the various steps required. These steps should make it obvious that after some exposure, getting to the point where you can first “draw” the circuit and run the simulation is pretty quick and direct.

After selecting the **Create document** key (the top left of screen), the following sequence will bring up the **Schematic** window: **ParallelDC-OK-Create a blank project-OK-PAGE1** (if necessary).

The voltage source and resistors are introduced as described in detail in earlier sections, but now the resistors need to be turned 90°. You can accomplish this by a right click of the mouse before setting a resistor in place. The resulting long list of options includes **Rotate**, which if selected will turn the resistor counterclockwise 90°. It can also be rotated by simultaneously selecting **Ctrl-R**. The resistor can then be placed in position by a left click of the mouse. An additional benefit of this maneuver is that the remaining resistors to be placed will already be in the vertical position. The values selected for the voltage source and resistors appear in Fig. 6.65.

Once the network is complete, the simulation and the results of Fig. 6.65 can be obtained through the following sequence: **Select New Simulation Profile key-Bias Point-Create-Analysis-Bias Point-OK-Run PSpice key-Exit(x)**.

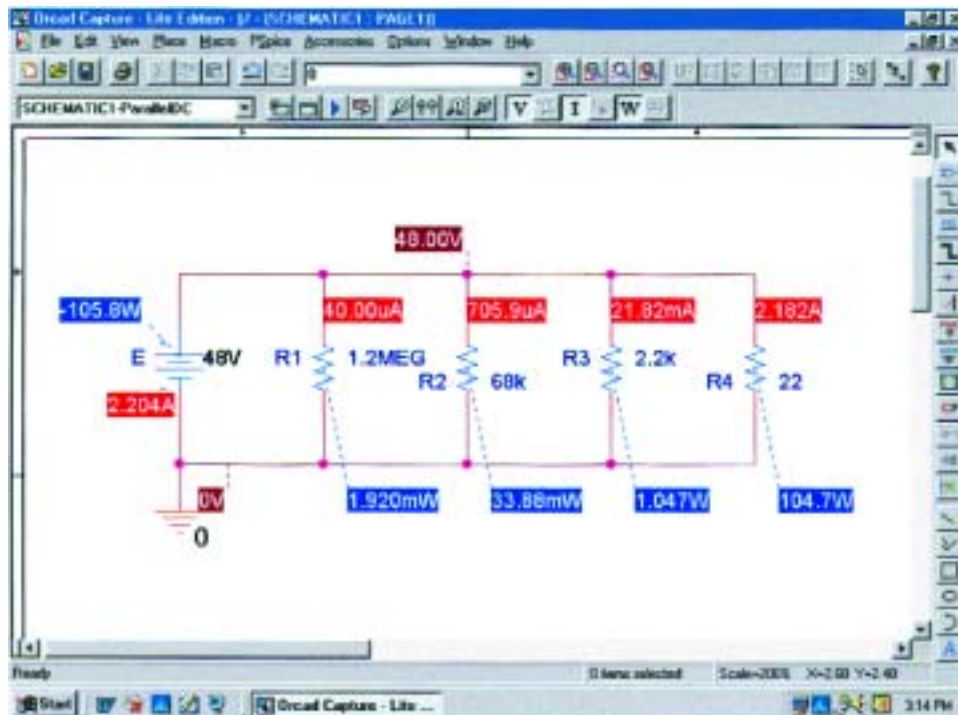


FIG. 6.65

Applying PSpice to a parallel network.

The result is Fig. 6.65 which clearly reveals that the voltage is the same across all the parallel elements and the current increases significantly with decrease in resistance. The range in resistor values suggests, by inspection, that the total resistance will be just less than the smallest resistance of  $22\ \Omega$ . Using Ohm's law and the source current of  $2.204\ \text{A}$  results in a total resistance of  $R_T = E/I_s = 48\ \text{V}/2.204\ \text{A} = 21.78\ \Omega$ , confirming the above conclusion.

## Electronics Workbench

**Parallel dc Network** For comparison purposes the parallel network of Fig. 6.65 will now be analyzed using Electronics Workbench. The source and ground are selected and placed as shown in Fig. 6.66 using the procedure defined in the previous chapters. For the resistors, **VIRTUAL\_RESISTOR** is chosen, but it must be rotated  $90^\circ$  to match the configuration of Fig. 6.65. You can accomplish this by first clicking on the resistor symbol to place it in the active state. Be sure that the resulting small black squares surround the symbol, label, and value; otherwise, you may have activated only the label or value. Then right-click the mouse. The **90 Clockwise** can then be selected, and the resistor will be turned automatically. Unfortunately, there is no continuum here, so the next resistor will have to be turned using the same procedure. The values of each resistor are set by double-clicking on the resistor symbol to obtain the **Virtual Resistor** dialog box. Remember that the unit of measurement is controlled by the scrolls at the right of the unit of measurement. For EWB, unlike PSpice, megohm uses capital **M** and milliohm uses lowercase **m**.

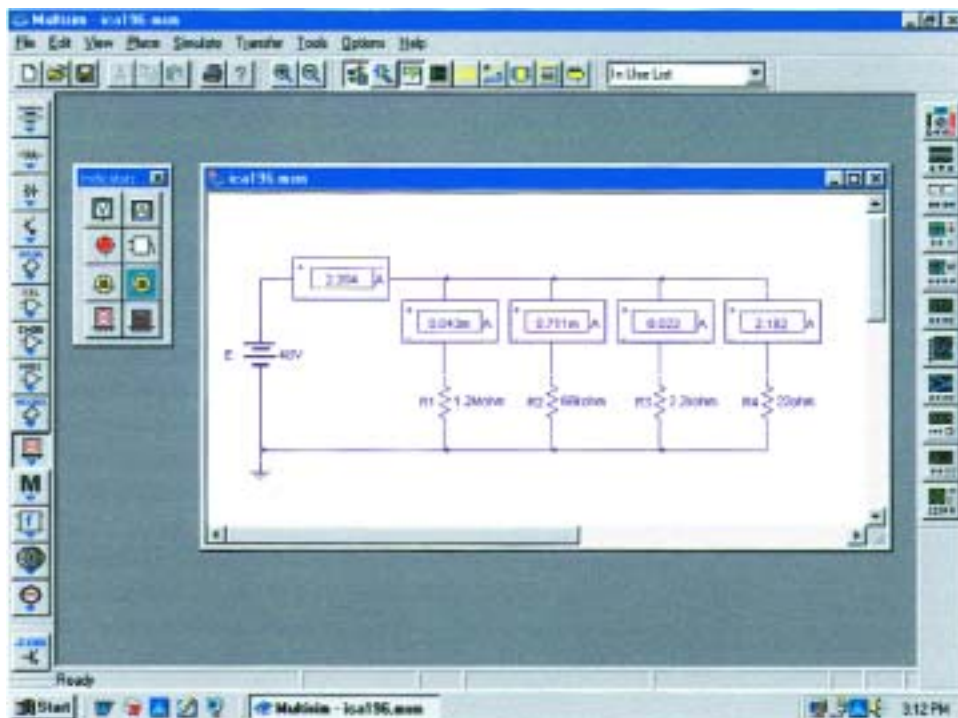


FIG. 6.66

Using the indicators of Electronics Workbench to display the currents of a parallel dc network.

This time, rather than using meters to make the measurements, we will use indicators. The **Indicators** key pad is the tenth down on the left toolbar. It has the appearance of an LCD display with the number 8. Once it has been selected, eight possible indicators will appear. For this example, the **A** indicator, representing an ammeter, will be used since we are interested only in the current levels. When **A** has been selected, a **Component Browser** will appear with four choices under the **Component Name List**; each option refers to a position for the ammeter. The **H** means “horizontal” as shown in the picture window when the dialog box is first opened. The **HR** means “horizontal,” but with the polarity reversed. The **V** is for a vertical configuration with the positive sign at the top, and the **VR** is the vertical position with the positive sign at the bottom. Simply select the one you want followed by an **OK**, and your choice will appear in that position on the screen. Click it into position, and you can return for the next indicator. Once all the elements are in place and their values set, simulation can be initiated with the sequence **Simulate-Run**. The results shown in Fig. 6.66 will appear.

Note that all the results appear with the indicator boxes. All are positive results because the ammeters were all entered with a configuration that would result in conventional current entering the positive current. Also note that as was true for inserting the meters, the indicators are placed in series with the branch in which the current is to be measured.

## PROBLEMS

### SECTION 6.2 Parallel Elements

- For each configuration of Fig. 6.67, determine which elements are in series and which are in parallel.

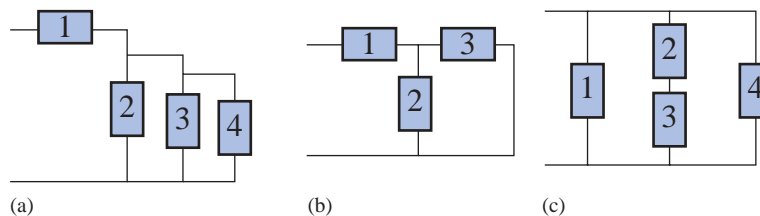


FIG. 6.67

Problem 1.

- For the network of Fig. 6.68:
  - Which elements are in parallel?
  - Which elements are in series?
  - Which branches are in parallel?

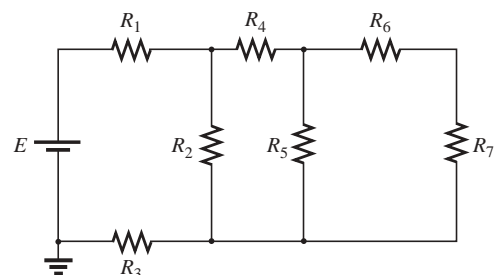
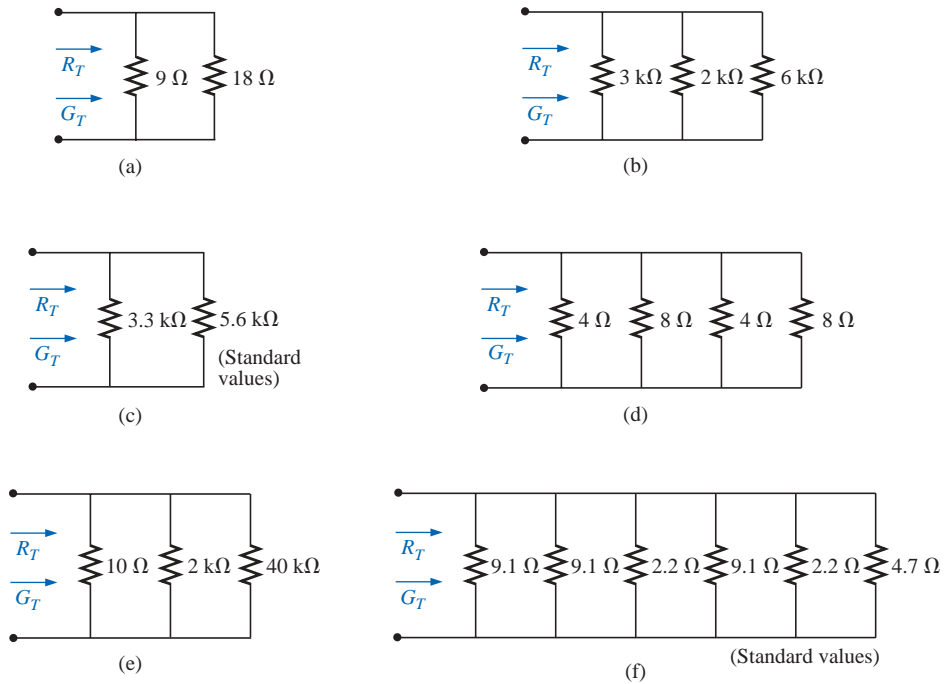


FIG. 6.68

Problem 2.

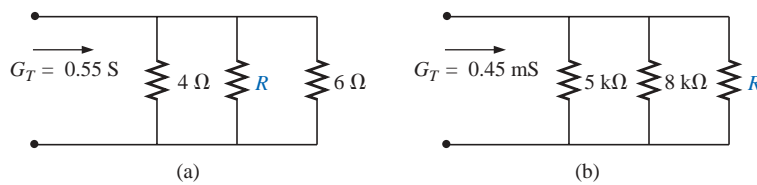
**SECTION 6.3 Total Conductance and Resistance**

3. Find the total conductance and resistance for the networks of Fig. 6.69.



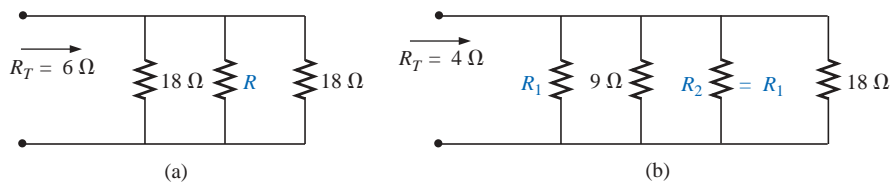
**FIG. 6.69**  
Problem 3.

4. The total conductance of each network of Fig. 6.70 is specified. Find the value in ohms of the unknown resistances.



**FIG. 6.70**  
Problem 4.

5. The total resistance of each circuit of Fig. 6.71 is specified. Find the value in ohms of the unknown resistances.



**FIG. 6.71**  
Problem 5.

- \*6. Determine the unknown resistors of Fig. 6.72 given the fact that  $R_2 = 5R_1$  and  $R_3 = (1/2)R_1$ .
- \*7. Determine  $R_1$  for the network of Fig. 6.73.

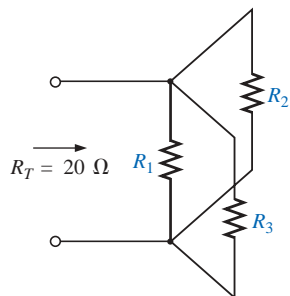


FIG. 6.72  
Problem 6.

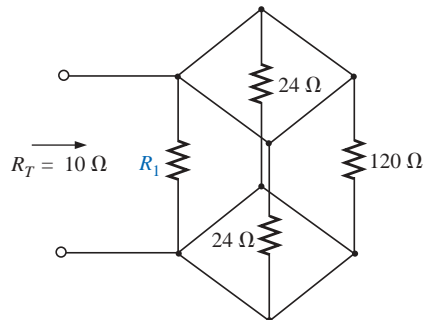


FIG. 6.73  
Problem 7.

SECTION 6.4 Parallel Circuits

- 8. For the network of Fig. 6.74:
  - a. Find the total conductance and resistance.
  - b. Determine  $I_s$  and the current through each parallel branch.
  - c. Verify that the source current equals the sum of the parallel branch currents.
  - d. Find the power dissipated by each resistor, and note whether the power delivered is equal to the power dissipated.
  - e. If the resistors are available with wattage ratings of 1/2, 1, 2, and 50 W, what is the minimum wattage rating for each resistor?
- 9. Repeat Problem 8 for the network of Fig. 6.75.

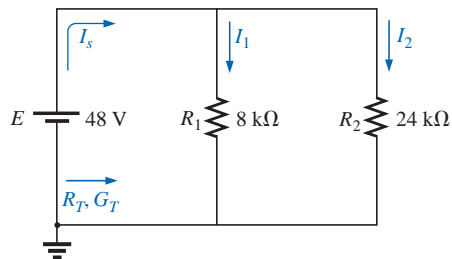


FIG. 6.74  
Problem 8.

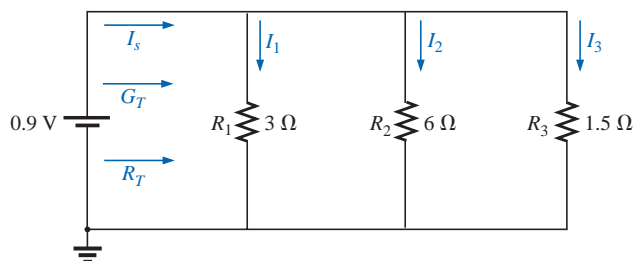


FIG. 6.75  
Problem 9.

- 10. Repeat Problem 8 for the network of Fig. 6.76 constructed of standard resistor values.

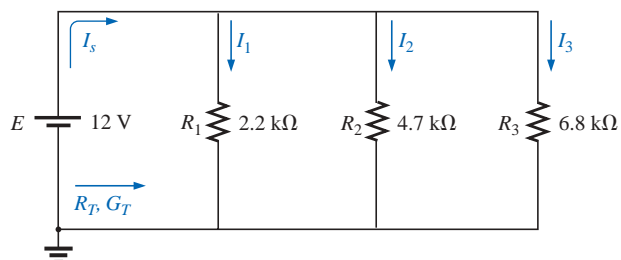
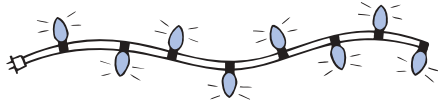
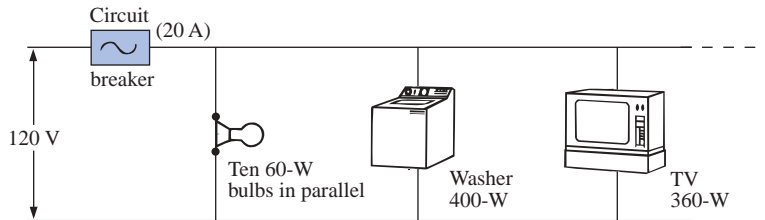


FIG. 6.76  
Problem 10.



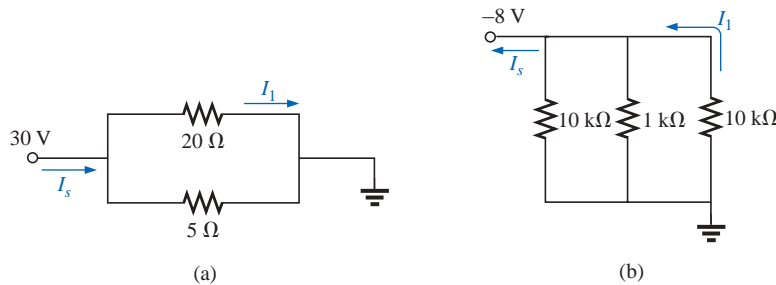
**FIG. 6.77**  
Problem 11.

11. Eight holiday lights are connected in parallel as shown in Fig. 6.77.
  - a. If the set is connected to a 120-V source, what is the current through each bulb if each bulb has an internal resistance of 1.8 k $\Omega$ ?
  - b. Determine the total resistance of the network.
  - c. Find the power delivered to each bulb.
  - d. If one bulb burns out (that is, the filament opens), what is the effect on the remaining bulbs?
  - e. Compare the parallel arrangement of Fig. 6.77 to the series arrangement of Fig. 5.87. What are the relative advantages and disadvantages of the parallel system compared to the series arrangement?
12. A portion of a residential service to a home is depicted in Fig. 6.78.
  - a. Determine the current through each parallel branch of the network.
  - b. Calculate the current drawn from the 120-V source. Will the 20-A circuit breaker trip?
  - c. What is the total resistance of the network?
  - d. Determine the power supplied by the 120-V source. How does it compare to the total power of the load?



**FIG. 6.78**  
Problems 12 and 37.

13. Determine the currents  $I_1$  and  $I_s$  for the networks of Fig. 6.79.



**FIG. 6.79**  
Problem 13.

14. Using the information provided, determine the resistance  $R_1$  for the network of Fig. 6.80.
- \*15. Determine the power delivered by the dc battery in Fig. 6.81.

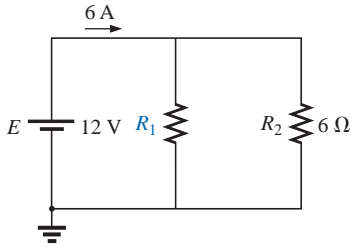


FIG. 6.80  
Problem 14.

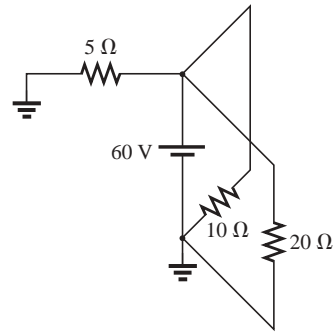


FIG. 6.81  
Problem 15.

- \*16. For the network of Fig. 6.82:
- Find the current  $I_1$ .
  - Calculate the power dissipated by the 4-Ω resistor.
  - Find the current  $I_2$ .

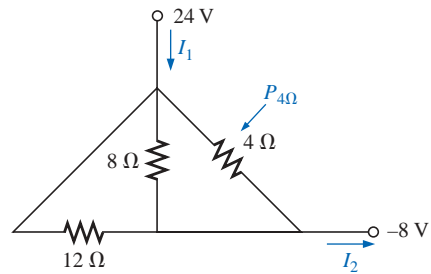


FIG. 6.82  
Problem 16.

- \*17. For the network of Fig. 6.83:
- Find the current  $I$ .
  - Determine the voltage  $V$ .
  - Calculate the source current  $I_s$ .

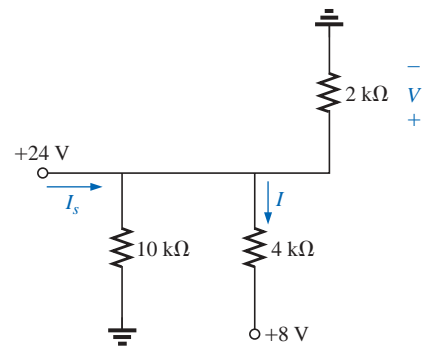
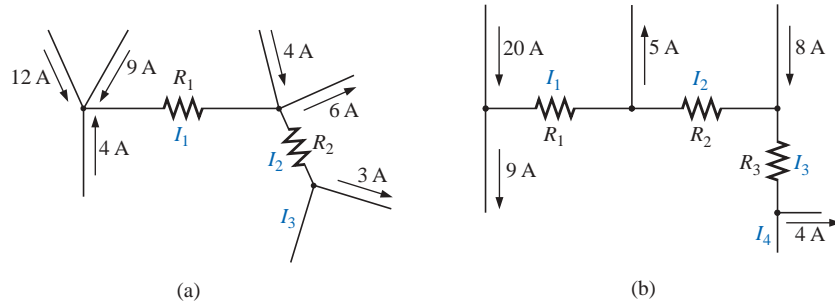


FIG. 6.83  
Problem 17.

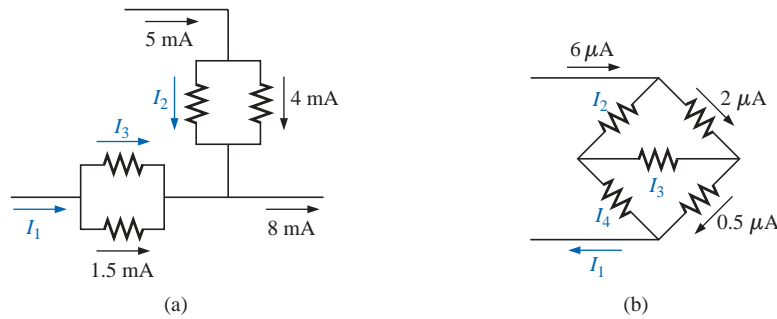
**SECTION 6.5 Kirchhoff's Current Law**

**18.** Find all unknown currents and their directions in the circuits of Fig. 6.84.



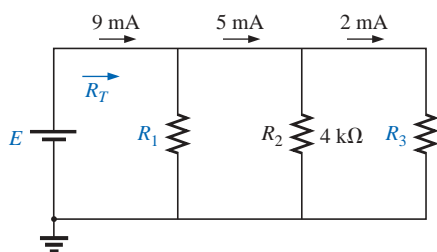
**FIG. 6.84**  
Problems 18 and 38.

**\*19.** Using Kirchhoff's current law, determine the unknown currents for the networks of Fig. 6.85.



**FIG. 6.85**  
Problem 19.

**20.** Using the information provided in Fig. 6.86, find the branch resistors  $R_1$  and  $R_3$ , the total resistance  $R_T$ , and the voltage source  $E$ .



**FIG. 6.86**  
Problem 20.



\*21. Find the unknown quantities for the circuits of Fig. 6.87 using the information provided.

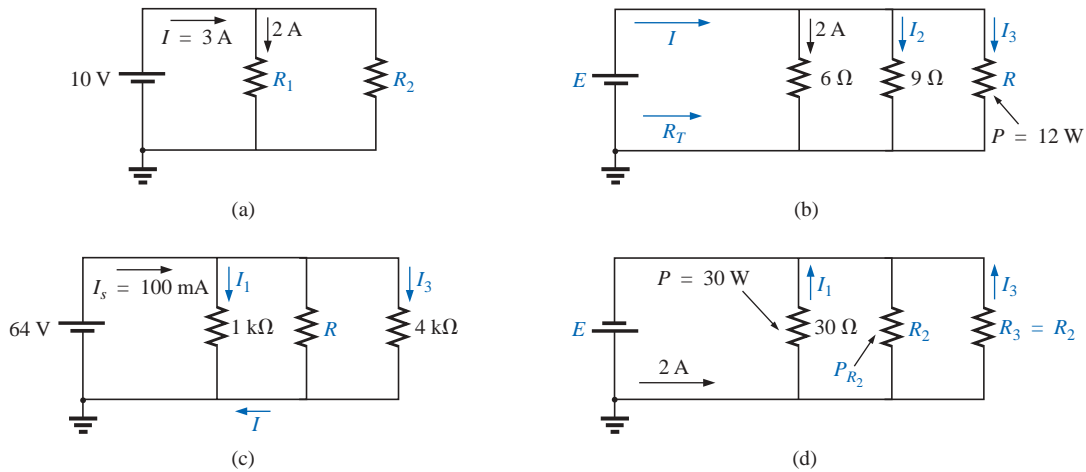


FIG. 6.87  
Problem 21.

SECTION 6.6 Current Divider Rule

- 22. Using the information provided in Fig. 6.88, determine the current through each branch using simply the ratio of parallel resistor values. Then determine the total current  $I_T$ .
- 23. Using the current divider rule, find the unknown currents for the networks of Fig. 6.89.

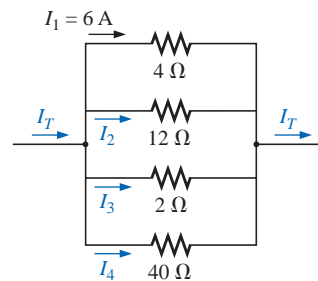


FIG. 6.88  
Problem 22.

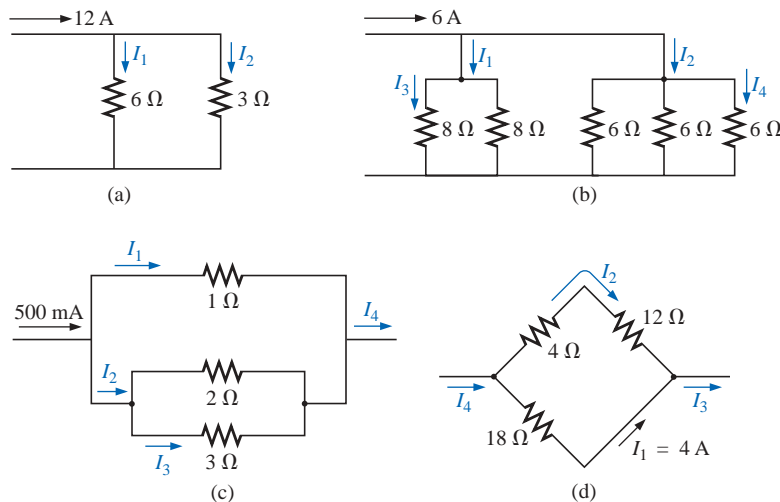
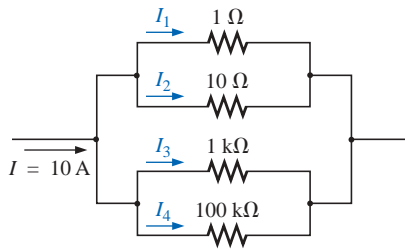
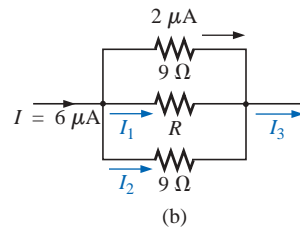
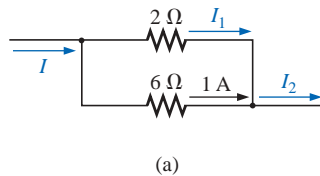


FIG. 6.89  
Problem 23.



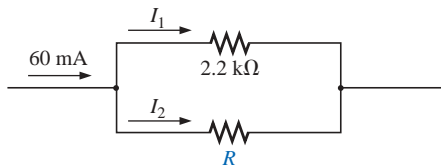
**FIG. 6.90**  
Problem 24.

- \*24. Parts (a), (b), and (c) of this problem should be done by inspection—that is, mentally. The intent is to obtain a solution without a lengthy series of calculations. For the network of Fig. 6.90:
- What is the approximate value of  $I_1$  considering the magnitude of the parallel elements?
  - What are the ratios  $I_1/I_2$  and  $I_3/I_4$ ?
  - What are the ratios  $I_2/I_3$  and  $I_1/I_4$ ?
  - Calculate the current  $I_1$ , and compare it to the result of part (a).
  - Determine the current  $I_4$  and calculate the ratio  $I_1/I_4$ . How does the ratio compare to the result of part (c)?
25. Find the unknown quantities using the information provided for the networks of Fig. 6.91.

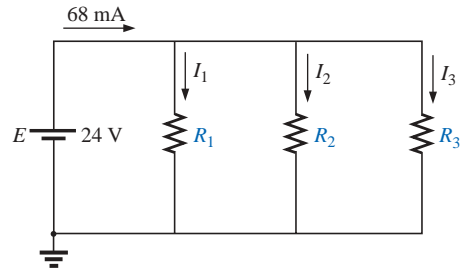


**FIG. 6.91**  
Problem 25.

- \*26. For the network of Fig. 6.92, calculate the resistor  $R$  that will ensure the current  $I_1 = 3I_2$ .
- \*27. Design the network of Fig. 6.93 such that  $I_2 = 4I_1$  and  $I_3 = 3I_2$ .



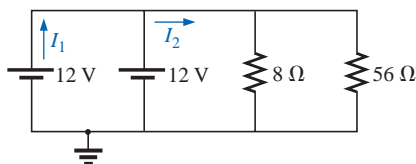
**FIG. 6.92**  
Problem 26.



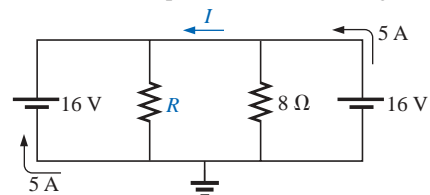
**FIG. 6.93**  
Problem 27.

**SECTION 6.7 Voltage Sources in Parallel**

- Assuming identical supplies, determine the currents  $I_1$  and  $I_2$  for the network of Fig. 6.94.
- Assuming identical supplies, determine the current  $I$  and resistance  $R$  for the parallel network of Fig. 6.95.



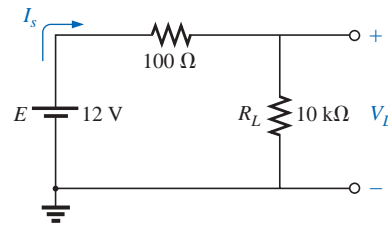
**FIG. 6.94**  
Problem 28.



**FIG. 6.95**  
Problem 29.

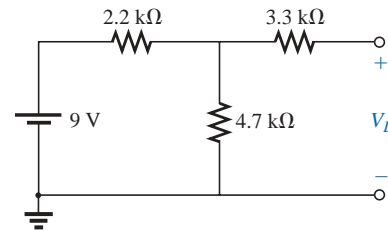
**SECTION 6.8 Open and Short Circuits**

30. For the network of Fig. 6.96:
- Determine  $I_s$  and  $V_L$ .
  - Determine  $I_s$  if  $R_L$  is shorted out.
  - Determine  $V_L$  if  $R_L$  is replaced by an open circuit.



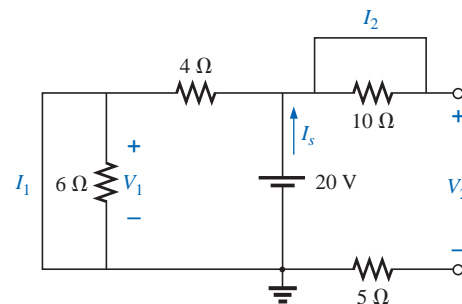
**FIG. 6.96**  
Problem 30.

31. For the network of Fig. 6.97:
- Determine the open-circuit voltage  $V_L$ .
  - If the 2.2-k $\Omega$  resistor is short circuited, what is the new value of  $V_L$ ?
  - Determine  $V_L$  if the 4.7-k $\Omega$  resistor is replaced by an open circuit.



**FIG. 6.97**  
Problem 31.

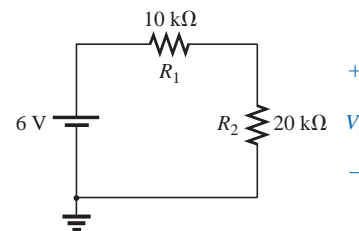
- \*32. For the network of Fig. 6.98, determine
- the short-circuit currents  $I_1$  and  $I_2$ .
  - the voltages  $V_1$  and  $V_2$ .
  - the source current  $I_s$ .



**FIG. 6.98**  
Problem 32.

**SECTION 6.9 Voltmeters: Loading Effect**

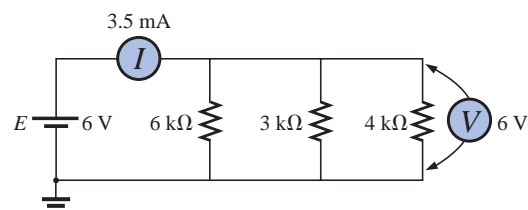
33. For the network of Fig. 6.99:
- Determine the voltage  $V_2$ .
  - Determine the reading of a DMM having an internal resistance of 11 M $\Omega$  when used to measure  $V_2$ .
  - Repeat part (b) with a VOM having an ohm/volt rating of 20,000 using the 10-V scale. Compare the results of parts (b) and (c). Explain any difference.
  - Repeat part (c) with  $R_1 = 100$  k $\Omega$  and  $R_2 = 200$  k $\Omega$ .
  - Based on the above, can you make any general conclusions about the use of a voltmeter?



**FIG. 6.99**  
Problems 33 and 40.

**SECTION 6.10 Troubleshooting Techniques**

34. Based on the measurements of Fig. 6.100, determine whether the network is operating correctly. If not, try to determine why.



**FIG. 6.100**  
Problem 34.

35. Referring to the network of Fig. 6.101, is  $V_a = 8.8 \text{ V}$  the correct reading for the given configuration? If not, which element has been connected incorrectly in the network?

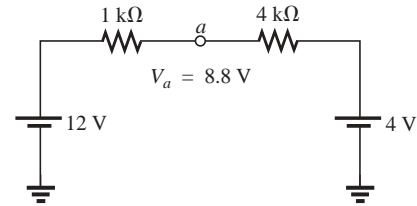


FIG. 6.101  
Problem 35.

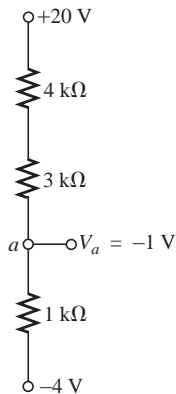


FIG. 6.102  
Problem 36.

36. a. The voltage  $V_a$  for the network of Fig. 6.102 is  $-1 \text{ V}$ . If it suddenly jumped to  $20 \text{ V}$ , what could have happened to the circuit structure? Localize the problem area.  
b. If the voltage  $V_a$  is  $6 \text{ V}$  rather than  $-1 \text{ V}$ , try to explain what is wrong about the network construction.

### SECTION 6.12 Computer Analysis

#### PSpice or Electronics Workbench

37. Using schematics, determine all the currents for the network of Fig. 6.78.  
38. Using schematics, determine the unknown quantities for the network of Fig. 6.84.

#### Programming Language (C++, QBASIC, Pascal, etc.)

39. Write a program to determine the total resistance and conductance of any number of elements in parallel.  
40. Write a program that will tabulate the voltage  $V_2$  of Fig. 6.99 measured by a VOM with an internal resistance of  $200 \text{ k}\Omega$  as  $R_2$  varies from  $10 \text{ k}\Omega$  to  $200 \text{ k}\Omega$  in increments of  $10 \text{ k}\Omega$ .

## GLOSSARY

**Current divider rule (CDR)** A method by which the current through parallel elements can be determined without first finding the voltage across those parallel elements.

**Kirchhoff's current law (KCL)** The algebraic sum of the currents entering and leaving a node is zero.

**Node** A junction of two or more branches.

**Ohm/volt ( $\Omega/\text{V}$ ) rating** A rating used to determine both the current sensitivity of the movement and the internal resistance of the meter.

**Open circuit** The absence of a direct connection between two points in a network.

**Parallel circuit** A circuit configuration in which the elements have two points in common.

**Short circuit** A direct connection of low resistive value that can significantly alter the behavior of an element or system.