

Traffic Engineering Applications

Road Intersection, Types of Intersection at Grade and Grade Separated, Channelization's

What is an Road Intersection

An intersection is an area shared by two or more roads. Its main function is to allow the change of route directions.

A simple intersection consists of two intersecting roads; a complex intersection serves several intersecting roads within the same area. The intersection is therefore an area of decision for all drivers; each must select one of the available choices to proceed. This requires an additional effort by the driver that is not necessary in non intersection areas of a highway. The flow of traffic on any street or highway is greatly affected by the flow of traffic through the intersection points on that street or highway because the intersection usually performs at a level below that of any other section of the road.

Types of Intersection

Intersections are nodes in the transportation network, the point at which two roads meet to form an at-grade junction. The traffic control type of the intersection governs the rules for how the traffic streams from these two roads interact. General intersection forms include yield-controlled intersections, stop-controlled intersections, signalized intersections, and modern roundabouts.

The type of intersection control impacts most, if not all, aspects of highway engineering described in this book, including planning for the adequate size of the intersection, geometric design and appropriate alignment of the intersection and its approaches, operational characteristics and capacity of the intersection, safety performance of the intersection, and other engineering considerations such as geotechnical and hydraulics aspects. These considerations interact and impact one another in roadway design and should be considered jointly in intersection design as well.

Intersections can be classified as grade-separated without ramps, grade-separated with ramps (commonly known as interchanges), or at-grade. Interchanges consist of structures that provide for the cross flow of traffic at different levels without interruption, thus reducing delay, particularly when volumes are high.

A. Simple

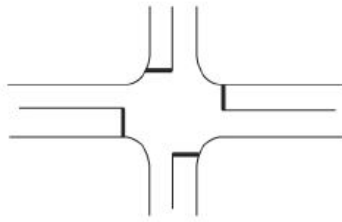

B. Flared

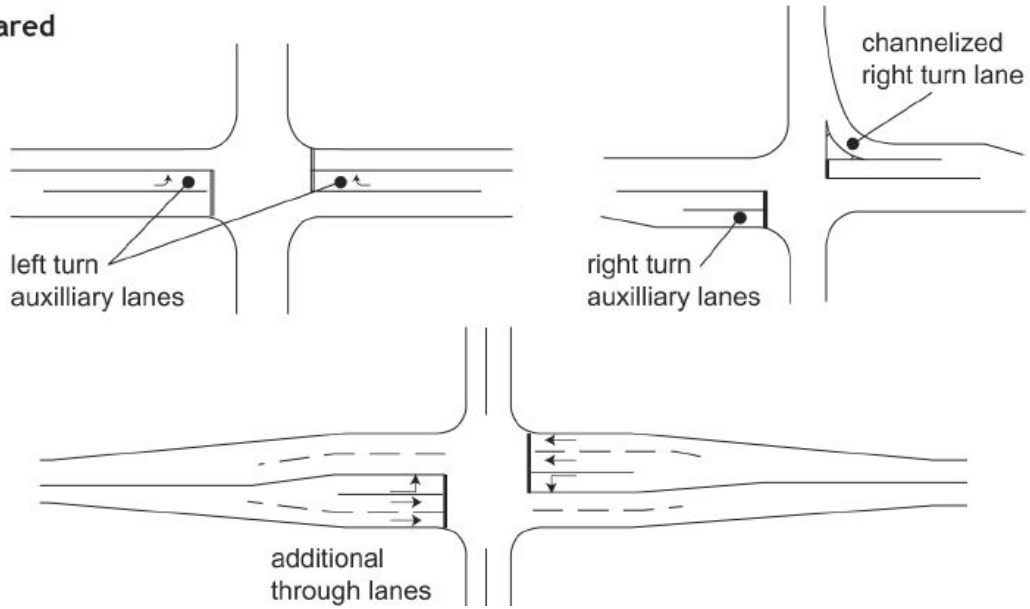

C. Channelized

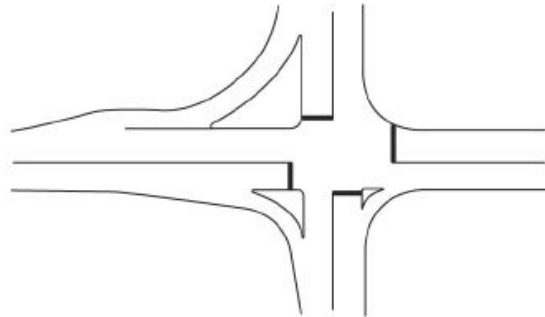

D. Roundabout

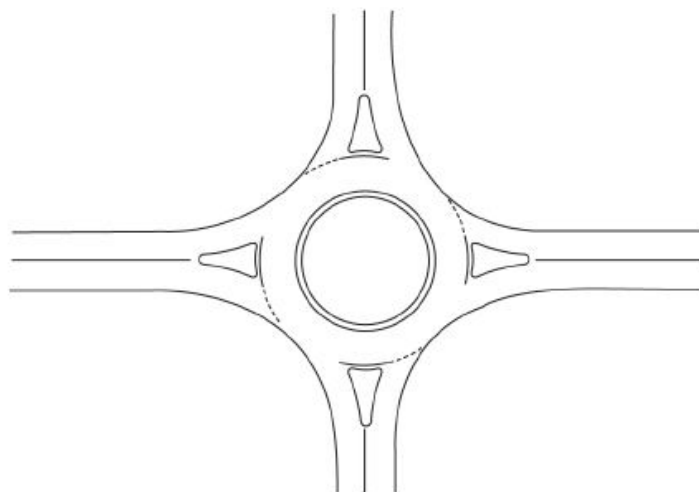

Figure: Types of Intersections

Classification of Road Intersections on the basis of number of roads intersecting:

3-Way Intersection:

Also known as *T or Y Junction* is the linking of three roads.

4-Way Intersection:

These are the most common intersections where crossing over of two roads is involved. It is further divided into two categories depending on the angle by which the two roads intersect each other.

When the two joining roads intersect each other perpendicularly, it is termed as a *Regular Intersection*. When the two roads cross at a different angle the junction is called a *Skewed Intersection*.

5-Way Intersection:

Crossing over of five roads.

6-Way Intersection:

Involves the crossing of three streets; most often a crossing of two perpendicular streets and a diagonal street.

Classification of Road Crossings on the basis of Traffic Control

Uncontrolled Intersection is a junction without signs or traffic signals. In such junctions the right of way belongs to the vehicle on the major road in case of a 3-way intersection and the traffic on the right in case of 4-way intersections. However the priorities vary for different countries. An uncontrolled intersection reduces delays but maximizes the chances of collisions especially if the junction has a high volume of traffic.

Controlled Intersections are either *signalized* or regulated by means of a *roundabout* or traffic signs.

Manually Controlled Intersections are junctions that are controlled by traffic police. This is usually practiced on low volume intersections.

Traffic signals are installed at relatively high traffic volume intersections. The traffic signals define a clear right of way to the drivers and thus improve the mobility of the traffic at such high volume intersections.

For low volume junctions, generally the installation of traffic signs or roundabouts assures fine serviceability. Traffic signals are more commonly seen in the case of 4-way intersections. High or low volume intersections if not controlled properly are considered the most risky locations in terms of conflicts.

The intersections become more hazardous when they are located just near the ending or starting of a flyover/underpass, as the driver is in the ascending or descending mode and thus

faces difficulties in controlling the vehicle as it approaches the intersection. There are various road traffic safety signs to warn the road users about the approaching intersection to reduce the chances of collisions. These signs also put in the picture about the type of intersection that is about to appear to further spell out the road geometry to the driver.

Three Approaches

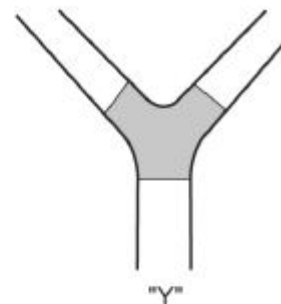
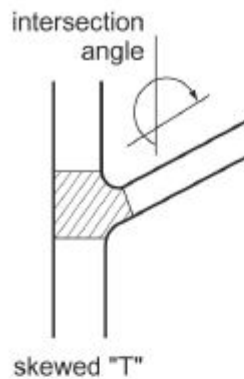
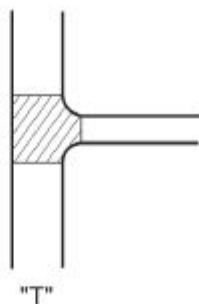

Four Approaches

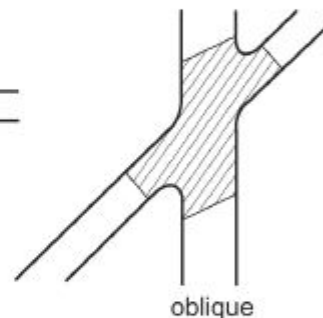
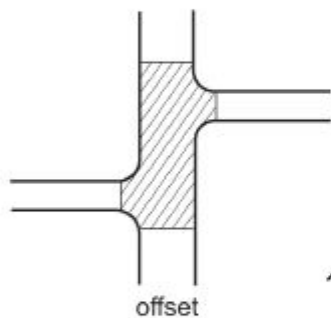
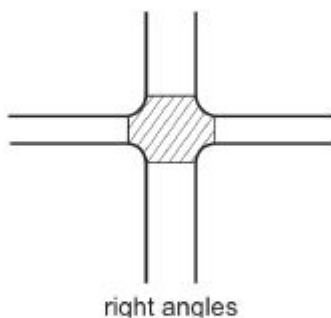

Five or More Approaches

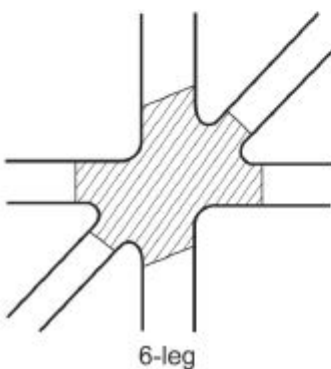
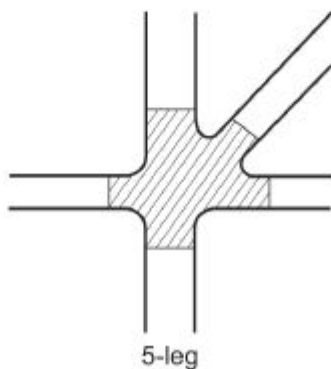

Conflicts at an Intersection

Conflicts at an intersection are different for different types of intersection. Consider a typical four-legged intersection as shown in figure. The number of conflicts for competing through movements are 4, while competing right turn and through movements are 8. The conflicts between right turn traffics are 4, and between left turn and merging traffic is 4. The conflicts created by pedestrians will be 8 taking into account all the four approaches. Diverging traffic also produces about 4 conflicts. Therefore, a typical four legged intersection has about 32 different types of conflicts. This is shown in Figure 1.

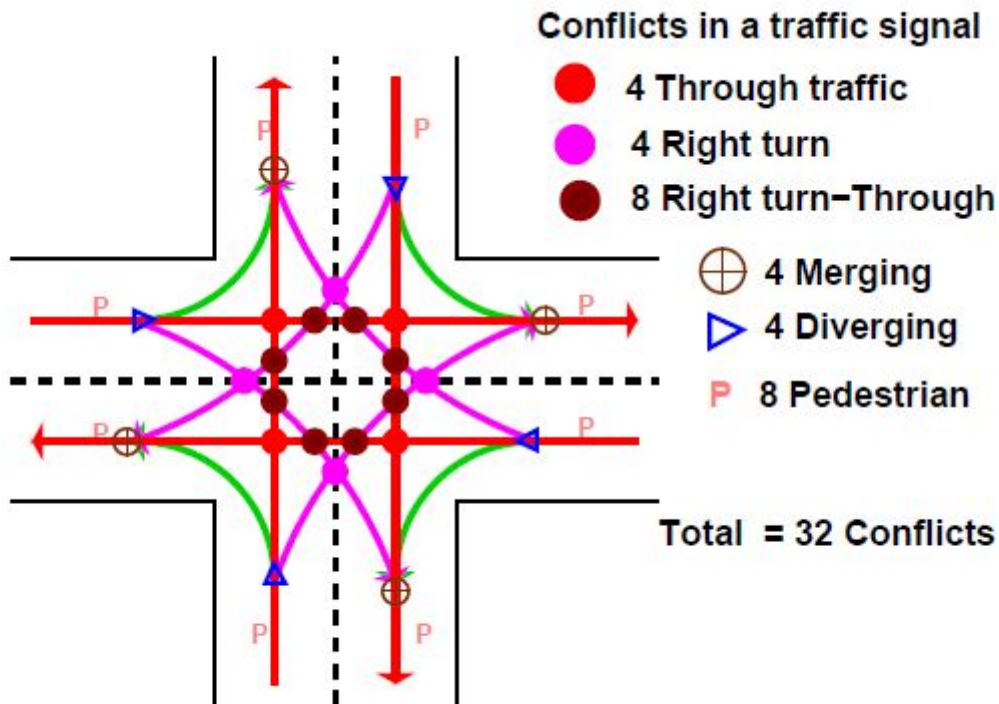

Figure: Conflicts at an Intersection.