

## CHAPTER TEN

### Chemicals Based on Benzene, Toluene, and Xylenes

#### INTRODUCTION

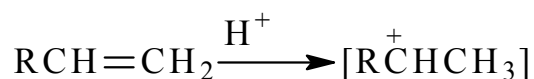
- ◆ The primary sources of benzene, toluene, and xylenes (BTX) are refinery streams, especially from catalytic reforming and cracking, and pyrolysis gasoline from steam cracking and from coal liquids.
- ◆ BTX and ethyl benzene are extracted from these streams using selective solvents such as sulfolene or ethylene glycol. The extracted components are separated through lengthy fractional distillation, crystallization, and isomerization processes.
- ◆ The reactivity of C<sub>6</sub>, C<sub>7</sub>, C<sub>8</sub> aromatics is mainly associated with the benzene ring. Aromatic compounds in general are liable for electrophilic substitution. Most of the chemicals produced directly from benzene are obtained from its reactions with electrophilic reagents.
- ◆ Benzene could be alkylated, nitrated, or chlorinated to important chemicals that are precursors for many commercial products.
- ◆ Toluene and xylenes (methylbenzenes) are substituted benzenes. Although the presence of methyl substituents activates the benzene ring for electrophilic attack, the chemistry of methylbenzenes for producing commercial products is more related to reactions with the methyl than with the phenyl group.
- ◆ As an electron-withdrawing substituent (of methane), the phenyl group influences the methyl hydrogens and makes them more available for chemical attack.
- ◆ The methyl group could be easily oxidized or chlorinated as a result of the presence of the phenyl substituent.

## **REACTIONS AND CHEMICALS OF BENZENE**

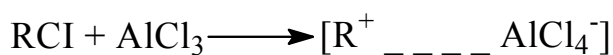
- ◆ Benzene ( $C_6H_6$ ) is the most important aromatic hydrocarbon. It is the precursor for many chemicals that may be used as end products or intermediates. Almost all compounds derived directly from benzene are converted to other chemicals and polymers.
- ◆ For example, hydrogenation of benzene produces cyclohexane. Oxidation of cyclohexane produces cyclohexanone, which is used to make caprolactam for nylon manufacture.
- ◆ Due to the resonance stabilization of the benzene ring, it is not easily polymerized.
- ◆ However, products derived from benzene such as styrene, phenol, and malefic anhydride can polymerize to important commercial products due to the presence of reactive functional groups.
- ◆ Benzene could be alkylated by different alkylating agents, hydrogenated to cyclohexane, nitrated, or chlorinated.

## ALKYLATION OF BENZENE

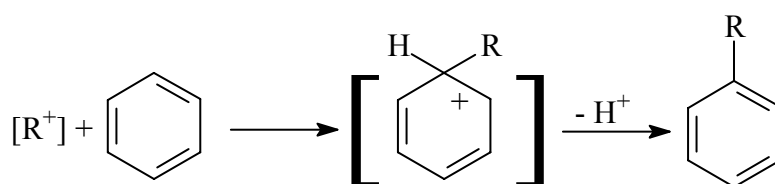
- ◆ Benzene can be alkylated in the presence of a Lewis or a Brønsted acid catalyst. Olefins such as ethylene, propylene, and alpha olefins are used to produce benzene alkylates, which have great commercial value. Alkyl halides such as monochloroparaffins in the C<sub>12</sub>-C<sub>14</sub> range also serve this purpose.
- ◆ The first step in alkylation is the generation of a carbocation (carbonium ion). When an olefin is the alkylating agent, a carbocation intermediate forms.



- ◆ Carbocations also form from an alkyl halide when a Lewis acid catalyst is used. Aluminum chloride is the commonly used Friedel-Crafts alkylation catalyst.
- ◆ Friedel-Crafts alkylation reactions have been reviewed by Roberts and Khalaf:



- ◆ The next step is an attack by the carbocation on the benzene ring, followed by the elimination of a proton and the formation of a benzene alkylate:



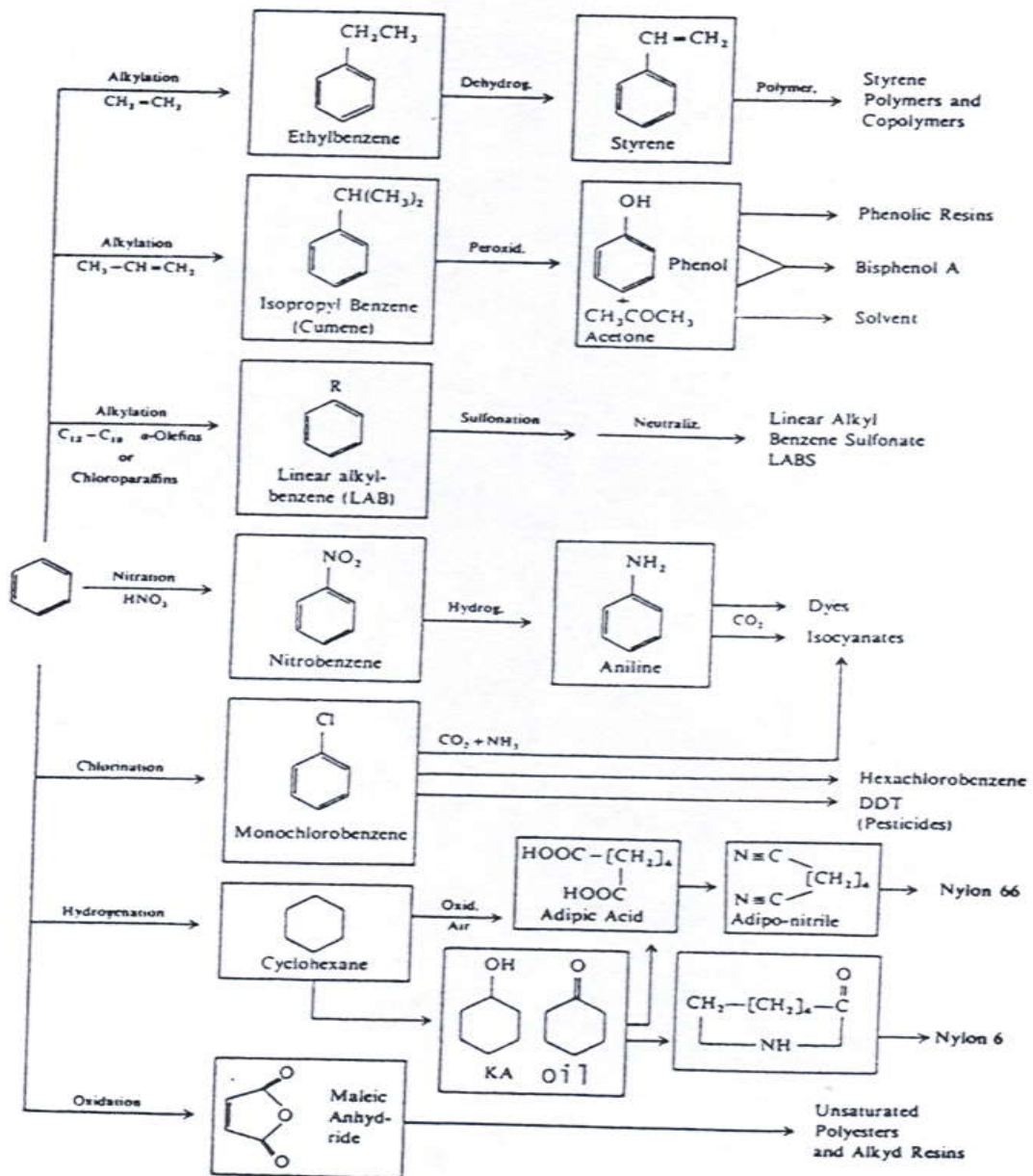
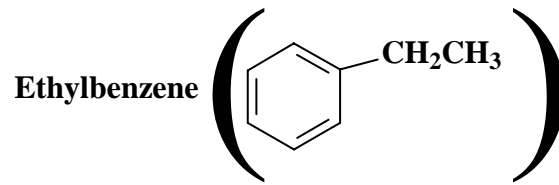
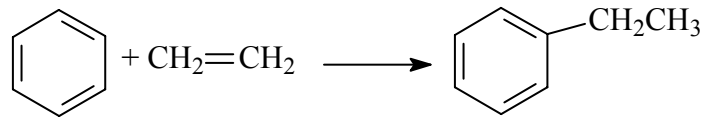


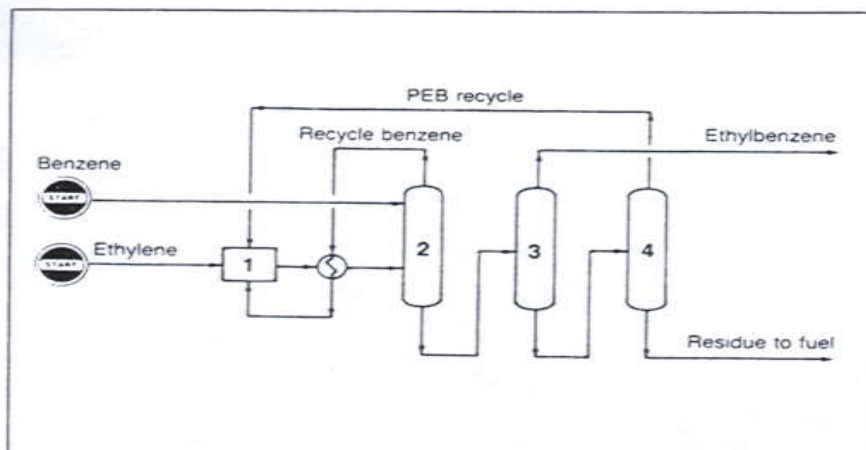
Figure 10-1. Important chemicals based on benzene.



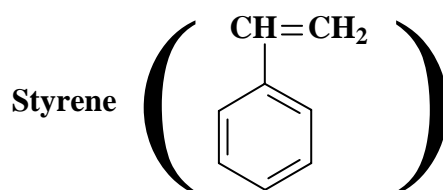
- ◆ The main process for producing EB is the catalyzed alkylation of benzene with ethylene:



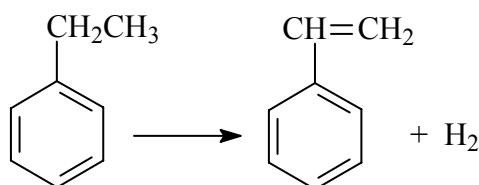
- ◆ Many different catalysts are available for this reaction.  $\text{AlCl}_3\text{-HCl}$  is commonly used. Ethyl chloride may be substituted for HCl in a mole-for-mole basis. Typical reaction conditions for the liquid-phase  $\text{AlCl}_3$  catalyzed process are  $40\text{-}100^\circ\text{C}$  and 2-8 atmospheres.
- ◆ Diethylbenzene and higher alkylated benzenes also form. They are recycled and dealkylated to EB.
- ◆ The vapor-phase Badger process (Figure 10-2), which has been commercialized since 1980, can accept dilute ethylene streams such as those produced from FCC off gas.
- ◆ A zeolite type heterogeneous catalyst is used in a fixed bed process. The reaction conditions are  $420^\circ\text{C}$  and 200-300 psi. Over 98% yield is obtained at 90% conversion.
- ◆ Polyethylbenzene (polyalkylated) and unreacted benzene are recycled and join the fresh feed to the reactor. The reactor effluent is fed to the benzene fractionation system to recover unreacted benzene.
- ◆ The bottoms containing ethylbenzene and heavier polyalkylates are fractionated in two columns.



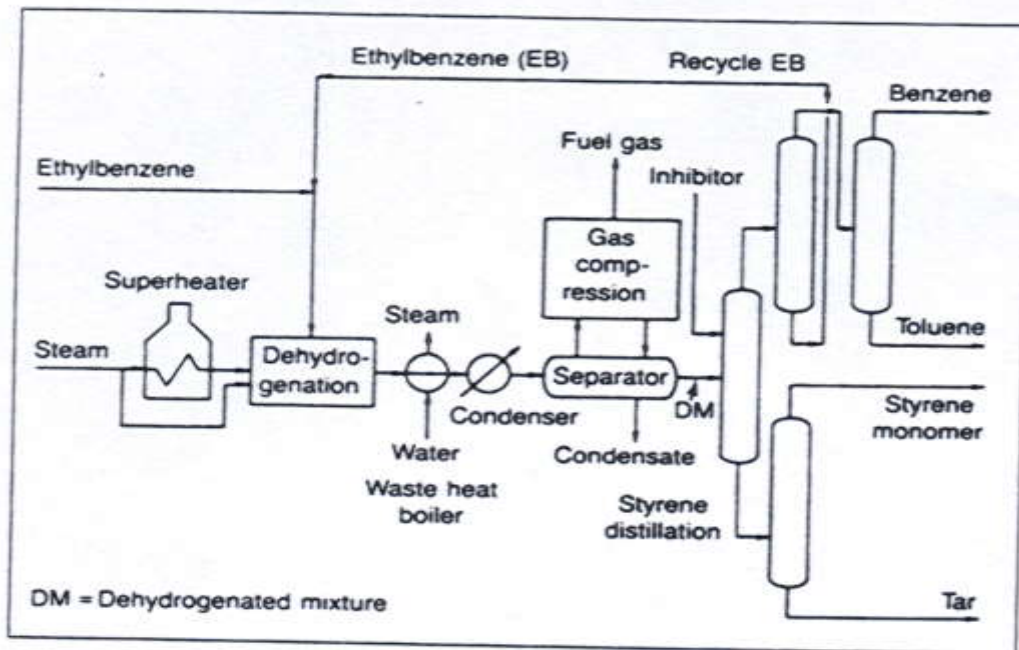
**Figure 10-2.** The Badger process for producing ethylbenzene: (1) reactor, (2) fractionator (for recovery of unreacted benzene), (3) EB fractionator, (4) polyethylbenzene recovery column.



- ◆ Styrene (vinylbenzene) is a liquid (b.p. 145.2°C) that polymerizes easily when initiated by a free radical or when exposed to light.
- ◆ Dehydrogenation of ethylbenzene to styrene occurs over a wide variety of metal oxide catalysts. Oxides of Fe, Cr, Si, Co, Zn, or their mixtures can be used for the dehydrogenation reaction.
- ◆ Typical reaction conditions for the vapor-phase process are 600-700°C, at or below atmospheric pressure. Approximately 90% styrene yield is obtained at 30-40% conversion:



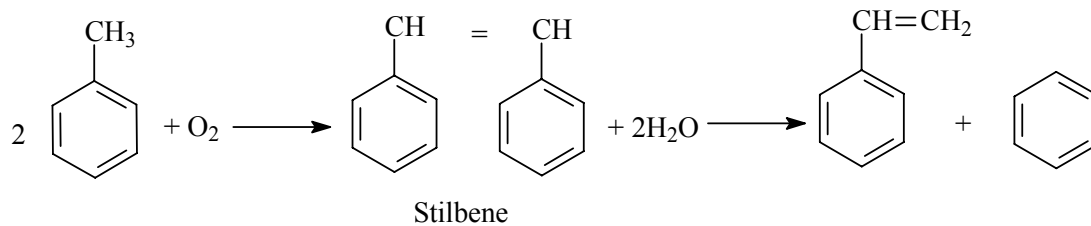
- ◆ In the Monsanto/Lummus Crest process (Figure 10-3), fresh ethylbenzene with recycled unconverted ethylbenzene are mixed with superheated steam.
- ◆ The steam acts as a heating medium and as a diluent. The endothermic reaction is carried out in multiple radial bed reactors filled with proprietary catalysts.



**Figure 10-3.** Schematic diagram of the Monsanto / Lummus Crest styrene plant.

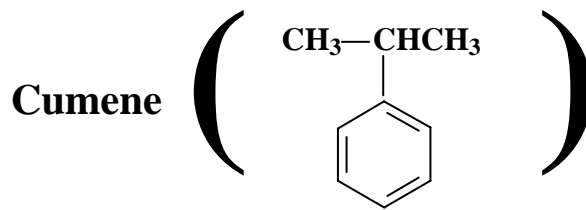
- ◆ Alternative routes for producing styrene have been sought. One approach is to dimerize butadiene to 4-vinyl-1-cyclohexene, followed by catalytic dehydrogenation to styrene.

- ◆ The process which was developed by DOW involves cyclodimerization of butadiene over a proprietary copper-loaded zeolite catalyst at moderate temperature and pressure (100°C and 250 psig).
- ◆ To increase the yield, the cyclodimerization step takes place in a liquid phase process over the catalyst. Selectivity for vinylcyclohexene (VCH) was over 99%.
- ◆ In the second step VCH is oxidized with oxygen over a proprietary oxide catalyst in presence of steam.
- ◆ Conversion over 90% and selectivity to styrene of 92% could be achieved.
- ◆ Another approach is the oxidative coupling of toluene to stilbene followed by disproportionation to styrene and benzene:

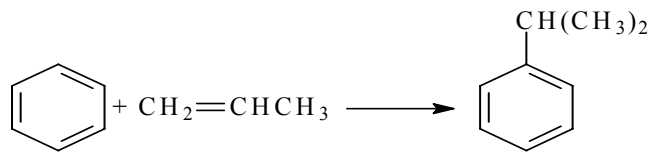


- ◆ High temperatures are needed for this reaction, and the yields are low.



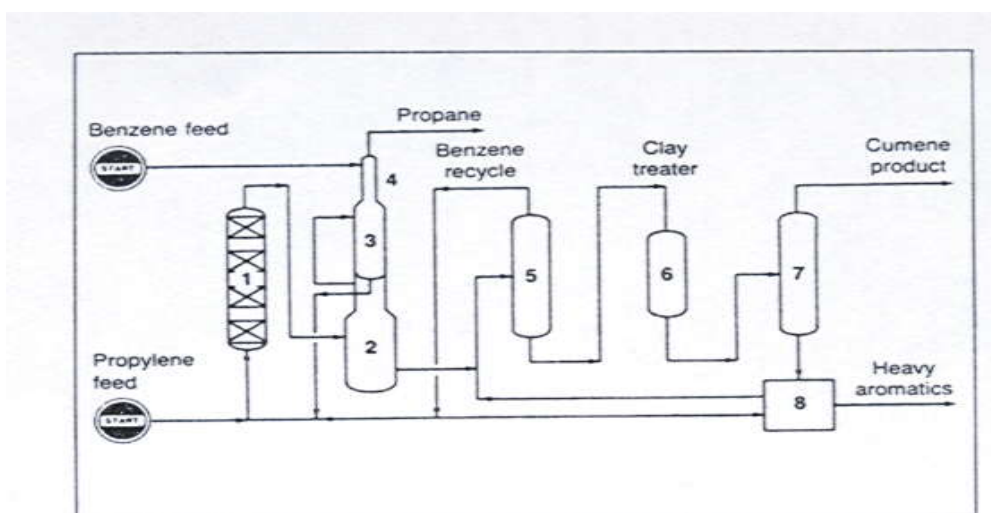
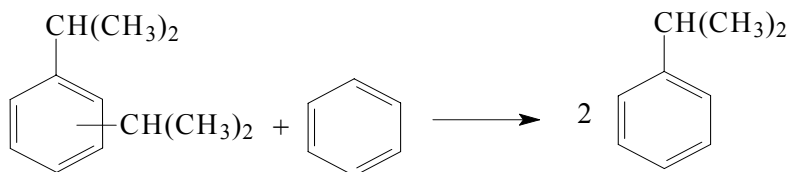


- ◆ Cumene (isopropylbenzene), a liquid, is soluble in many organic solvents but not in water. It is present in low concentrations in light refinery streams (such as reformates) and coal liquids. It may be obtained by distilling (cumene's B.P. is 152.7°C) these fractions.
- ◆ The main process for producing cumene is a synthetic route where benzene is alkylated with propylene to isopropylbenzene.
- ◆ Either a liquid or a gas-phase process is used for the alkylation reaction. In the liquid-phase process, low temperatures and pressures (approximately 50°C and 5 atmospheres) are used with sulfuric acid as a catalyst.



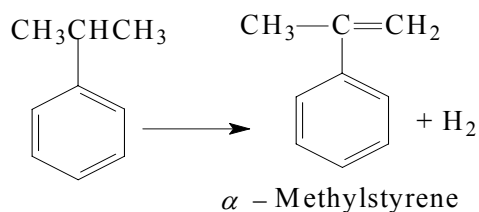
- ◆ Small amounts of ethylene can be tolerated since ethylene is quite unreactive under these conditions.
- ◆ Butylenes are relatively unimportant because butylbenzene can be removed as bottoms from the cumene column.
- ◆ In the vapor-phase process, the reaction temperature and pressure are approximately 250°C and 40 atmospheres.
- ◆ Phosphoric acid on Kieselguhr is a commonly used catalyst. To limit polyalkylation, a mixture of propene-propane feed is used. Propylene can be as low as 40% of the feed mixture.
- ◆ A high benzene/propylene ratio is also used to decrease polyalkylation. A selectivity of about 97% based on benzene can be obtained.
- ◆ The effluent is separated, and excess benzene recycled. Cumene is finally clay treated and fractionated. The bottom product is mainly

diisopropyl benzene, which is reacted with benzene in a transalkylation section:



**Figure 10-5.** A flow diagram of the UOP cumene process: (1) reactor, (2,3) two stage flash system, (4) depropanizer, (5) benzene column, (6) clay treatment, (7) fractionator, (8) transalkylation section.

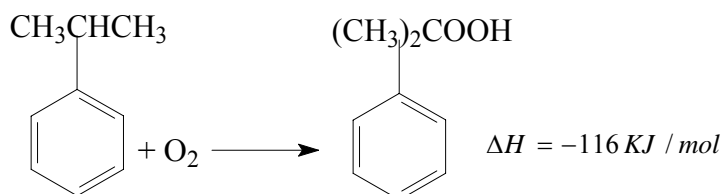
- ◆ To reduce pollution, Dow developed a new catalyst system from the mordenite-zeolite group to replace phosphoric acid or aluminum chloride catalysts. The new catalysts eliminate the disposal of acid wastes and handling corrosive materials.
- ◆ A small amount of cumene is used to make  $\alpha$ -methylstyrene by dehydrogenation.



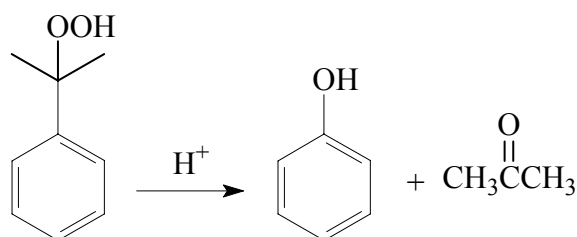
- ◆  $\alpha$ -Methylstyrene is used as a monomer for polymer manufacture and as a solvent.

## Phenol and Acetone from Cumene

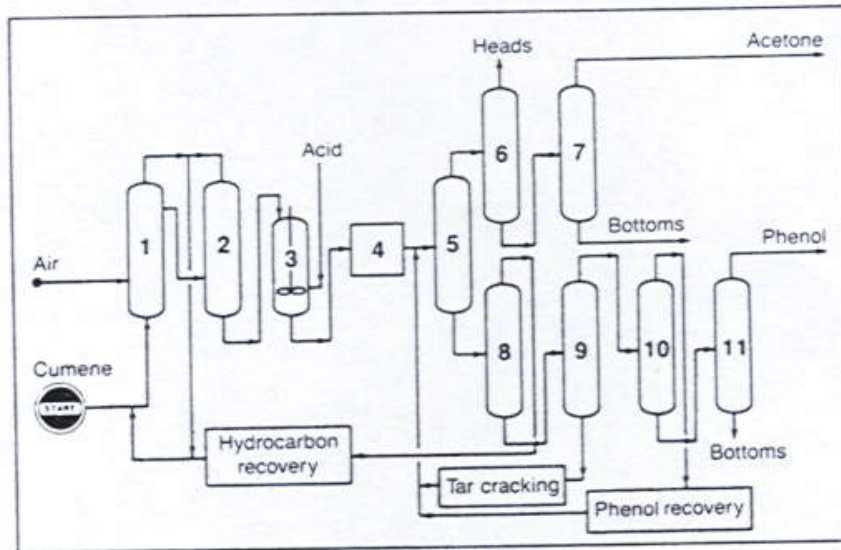
- ◆ Phenol,  $C_6H_5OH$  (hydroxybenzene), is produced from cumene by a two-step process. In the first step, cumene is oxidized with air to cumene hydroperoxide. The reaction conditions are approximately  $100-130^\circ C$  and 2-3 atmospheres in the presence of a metal salt catalyst:



- ◆ In the second step, the hydroperoxide is decomposed in the presence of an acid to phenol and acetone. The reaction conditions are approximately  $80^\circ C$  and slightly below atmospheric:



- ◆ In this process (Figure 10-6), cumene is oxidized in the liquid phase. The oxidation product is concentrated to 80% cumene hydroperoxide by vacuum distillation.
- ◆ To avoid decomposition of the hydroperoxide, it is transferred immediately to the cleavage reactor in the presence of a small amount of  $H_2SO_4$ . The cleavage product is neutralized with alkali before it is finally purified.



**Figure 10-6.** The Mitsui Petrochemical Industries process for producing phenol and acetone from cumene: (1) autooxidation reactor, (2) vacuum tower, (3) cleavage reactor, (4) neutralizer, (5-11) purification train.

- ◆ After an initial distillation to split the coproducts phenol and acetone, each is purified in separate distillation and treating trains.
- ◆ An acetone finishing column distills product acetone from an acetone/water/oil mixture.
- ◆ The oil, which is mostly unreacted cumene, is sent to cumene recovery. Acidic impurities, such as acetic acid and phenol, are neutralized by caustic injection.
- ◆ Cumene processes are currently the major source for phenol and coproduct acetone.
- ◆ Previously, phenol was produced from benzene by sulfonation followed by caustic fusion to sodium phenate.
- ◆ Phenol is released from the sodium salt of phenol by the action of carbon dioxide or sulfur dioxide.

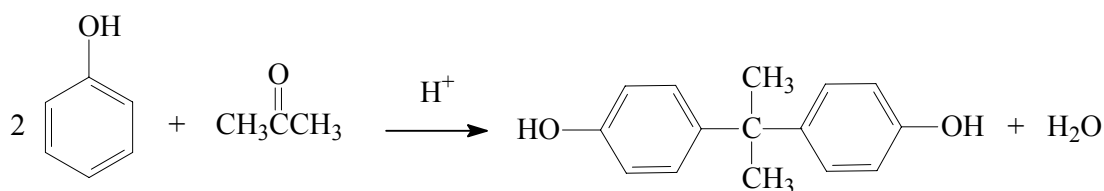
**Table 10-1 Feed composition of acetone finishing column**

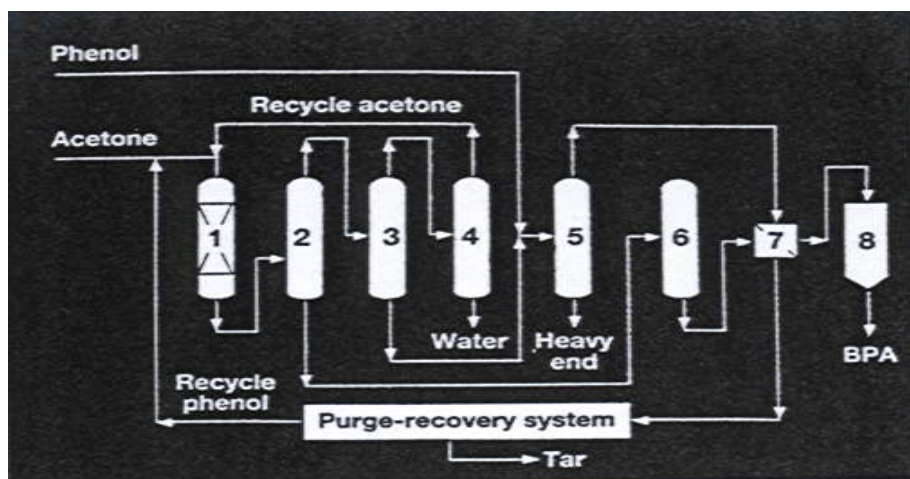
Component	wt%
Acetone	48%
Water	22%
Cumene	24%
Alpha-methylstyrene and other heavy hydrocarbons	4%
Neutralized organics (sodium acetate, sodium phenate, etc.)	1%
Free caustic	1%

- ◆ Direct hydroxylation of benzene to phenol could be achieved using zeolite catalysts containing rhodium, platinum, palladium, or irridium.
- ◆ The oxidizing agent is nitrous oxide, which is unavoidable a byproduct from the oxidation of KA oil (see KA oil, this chapter) to adipic acid using nitric acid as the oxidant.
- ◆ Phenol is also produced from chlorobenzene and from toluene via a benzoic acid intermediate.

### *Properties and Uses of Phenol*

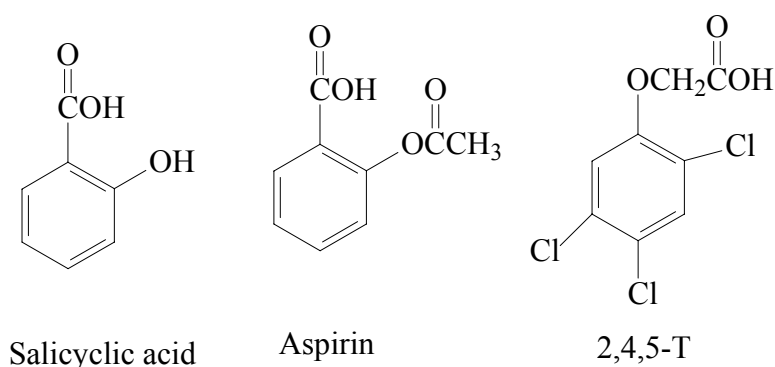
- ◆ Phenol, a white crystalline mass with a distinctive odor, becomes reddish when subjected to light.
- ◆ It is highly soluble in water, and the solution is weakly acidic.
- ◆ Many chemicals and polymers derive from phenol. Approximately 50% of production goes to phenolic resins.
- ◆ Phenol and acetone produce bis-phenol A, an important monomer for epoxy resins and polycarbonates. It is produced by condensing acetone and phenol in the presence of HCl, or by using a cation exchange resin.



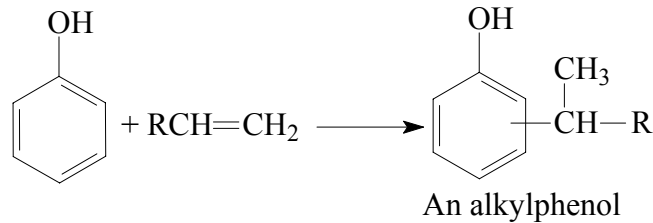


**Figure 10-8.** The CT-BISA (Chiyoda Corp.) process for producing bisphenol A from acetone and phenol. (1) reactor, (2-4) distillation columns, (5) phenol distillation column, (6) crystallizer, (7) solid/liquid separator, (8) prilling tower.

- ◆ Important chemicals derived from phenol are salicylic acid; acetylsalicylic acid (aspirin); 2,4-dichlorophenoxy acetic acid (2,4-D), and 2,4,5 triphenoxy acetic acid (2,4,5-T), which are selective herbicides; and pentachlorophenol, a wood preservative:

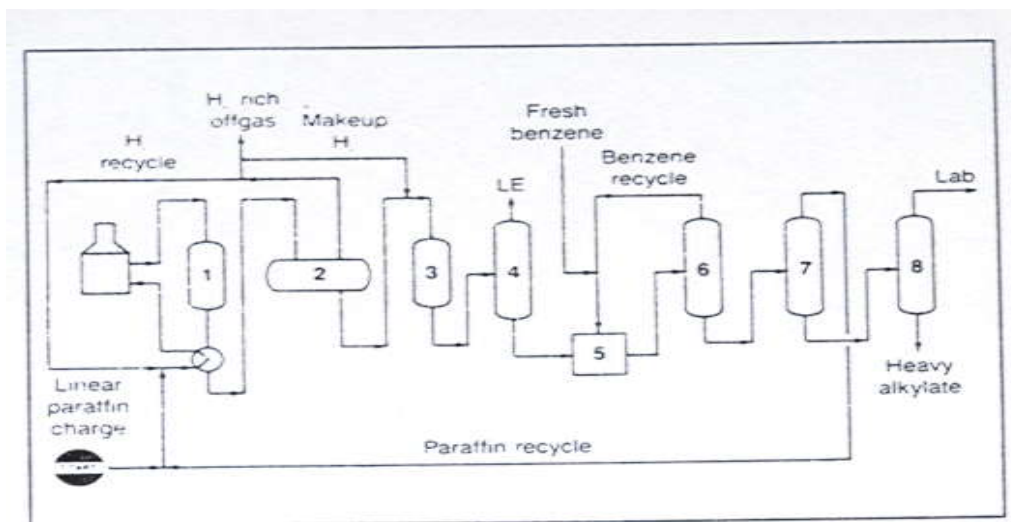
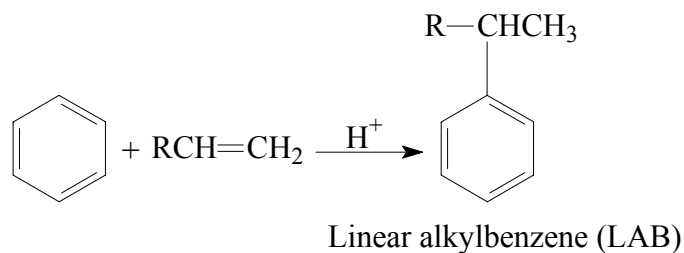


- ◆ About 12% of phenol demand is used to produce caprolactam, a monomer for nylon 6. The main source for caprolactam, however, is toluene.
- ◆ Phenol can be alkylated to alkylphenols. These compounds are widely used as nonionic surfactants, antioxidants, and monomers in resin polymer applications:



## Linear Alkylbenzene

- ◆ Linear alkylbenzene (LAB) is an alkylation product of benzene used to produce biodegradable anionic detergents. The alkylating agents are either linear  $C_{12}$ - $C_{14}$  mono-olefins or monochloroalkanes.
- ◆ The linear olefins (alpha olefins) are produced by polymerizing ethylene using Ziegler catalysts or by dehydrogenating n-paraffins extracted from kerosines.
- ◆ Monochloroalkanes, on the other hand, are manufactured by chlorinating the corresponding n-paraffins.
- ◆ Because the dehydrogenation product contains a higher concentration of olefins for a given alkylate production rate, the total hydrocarbon feed to the HF alkylation unit is substantially reduced.
- ◆ Alkylation of benzene with linear monoolefins is industrially preferred.
- ◆ The Detal process (Figure 10-9) combines the dehydrogenation of n-paraffins and the alkylation of benzene.
- ◆ Monoolefins from the dehydrogenation section are introduced to a fixed-bed alkylation reactor over a heterogeneous solid catalyst.
- ◆ Older processes use HF catalysts in a liquid phase process at a temperature range of 40-70°C. The general alkylation reaction of benzene using alpha olefins could be represented as:

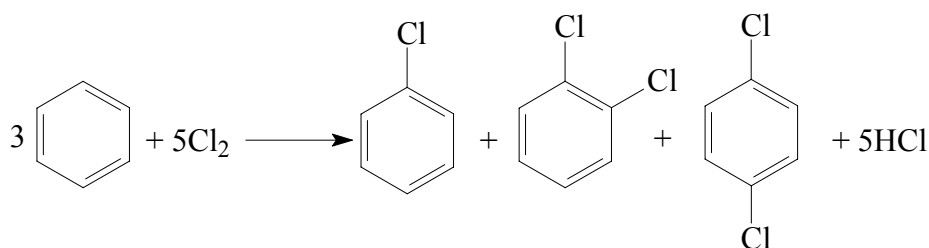


**Figure 10-9.** The UOP (Detal) process for producing linear alkylbenzene: (1) paraffin dehydrogenation reactor, (2) gas-liquid separation, (3) reactor for converting diolefins to monoolefins, (4) stripper, (5) alkylation reactor, (6,7,8) fractionators.

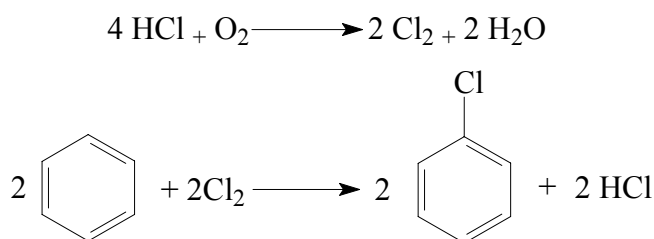
## CHLORINATION OF BENZENE

- ◆ Chlorination of benzene is an electrophilic substitution reaction in which  $\text{Cl}^+$  serves as the electrophile.
- ◆ The reaction occurs in the presence of a Lewis acid catalyst such as  $\text{FeCl}_3$ . The products are a mixture of mono- and dichlorobenzenes. The *ortho*- and the *para*-dichlorobenzene are more common than meta-dichlorobenzene.
- ◆ The ratio of the mono chloro to dichloro products essentially depends on the benzene/chlorine ratio and the residence time.
- ◆ The ratio of the dichloro-isomers (*o*- to *p*- to *m*-dichlorobenzenes) mainly depends on the reaction temperature and residence time:





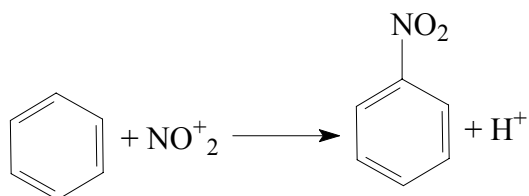
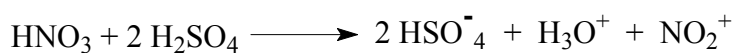
- ◆ Typical liquid-phase reaction conditions for the chlorination of benzene using  $\text{FeCl}_3$  catalyst are  $80\text{-}100^\circ\text{C}$  and atmospheric pressure.
- ◆ When a high benzene/ $\text{Cl}_2$  ratio is used, the product mixture is approximately 80% monochlorobenzene, 15% *p*-dichlorobenzene and 5% *o*-dichlorobenzene.
- ◆ Continuous chlorination processes permit the removal of monochlorobenzene as it is formed, resulting in lower yields of higher chlorinated benzene.
- ◆ Monochlorobenzene is also produced in a vapor-phase process at approximately  $300^\circ\text{C}$ .
- ◆ The by-product  $\text{HCl}$  goes into a regenerative oxychlorination reactor. The catalyst is a promoted copper oxide on a silica carrier:



- ◆ Monochlorobenzene is the starting material for many compounds, including phenol and aniline. Others, such as DDT, chloronitrobenzenes, polychlorobenzenes, and biphenyl, do not have as high a demand for monochlorobenzene as aniline and phenol.

## NITRATION OF BENZENE (Nitrobenzene [C<sub>6</sub>H<sub>5</sub>NO<sub>2</sub>])

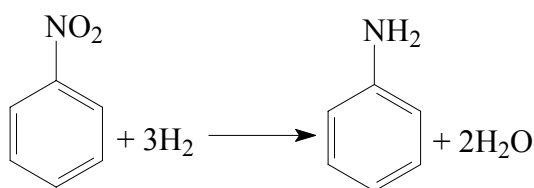
- ◆ Similar to the alkylation and the chlorination of benzene, the nitration reaction is an electrophilic substitution of a benzene hydrogen (a proton) with a nitronium ion (NO<sub>2</sub><sup>+</sup>).
- ◆ The liquid-phase reaction occurs in presence of both concentrated nitric and sulfuric acids at approximately 50°C.
- ◆ Concentrated sulfuric acid has two functions: it reacts with nitric acid to form the nitronium ion, and it absorbs the water formed during the reaction, which shifts the equilibrium to the formation of nitrobenzene:



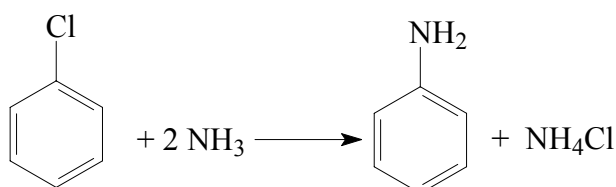
- ◆ Most of the nitrobenzene (~97%) produced is used to make aniline. Other uses include synthesis of quinoline, benzidine, and as a solvent for cellulose ethers.

### Aniline (C<sub>6</sub>H<sub>5</sub>NH<sub>2</sub>)

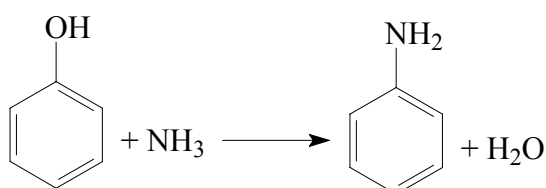
- ◆ Aniline (aminobenzene) is an oily liquid that turns brown when exposed to air and light. The compound is an important dye precursor.
- ◆ The main process for producing aniline is the hydrogenation of nitrobenzene:

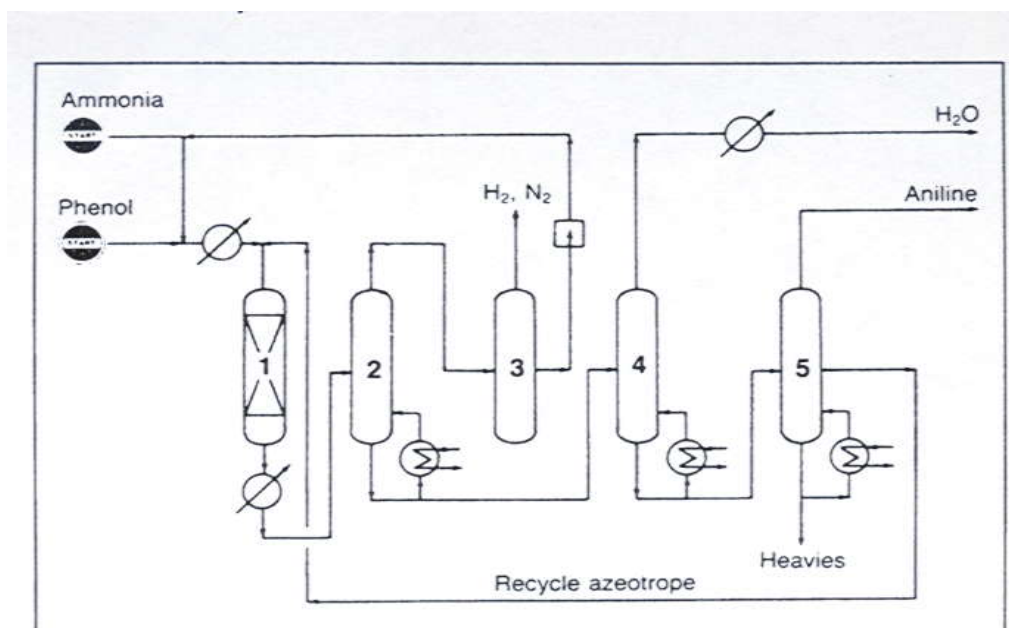


- ◆ The hydrogenation reaction occurs at approximately 270°C and slightly above atmospheric over a Cu/Silica catalyst. About a 95% yield is obtained.
- ◆ An alternative way to produce aniline is through ammonolysis of either chlorobenzene or phenol.
- ◆ The reaction of chlorobenzene with aqueous ammonia occurs over a copper salt catalyst at approximately 210°C and 65 atmospheres. The yield of aniline from this route is also about 96%:



- ◆ Ammonolysis of phenol occurs in the vapor phase. In the Scientific Design Co. process (Figure 10-10), a mixed feed of ammonia and phenol is heated and passed over a heterogeneous catalyst in a fixed-bed system.
- ◆ The reactor effluent is cooled, the condensed material distilled, and the unreacted ammonia recycled. Aniline produced this way should be very pure:

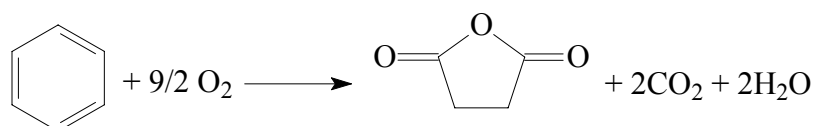




**Figure 10-10.** The Scientific Co. process for producing aniline from phenol: (1) fixed-bed reactor, (2) liquid-gas separator, (3) ammonia compression and recycling, (4) drier, (5) fractionator.

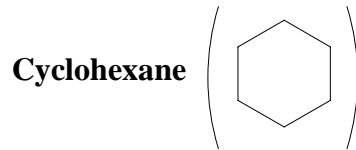
## OXIDATION OF BENZENE

- ◆ Benzene oxidation is the oldest method to produce malefic anhydride. The reaction occurs at approximately 380°C and atmospheric pressure.
- ◆ A mixture of  $V_2O_5/MO_3$  is the usual catalyst. Benzene conversion reaches 90%, but selectivity to malefic anhydride is only 50-60%; the other 40-50% is completely oxidized to  $CO_2$ :

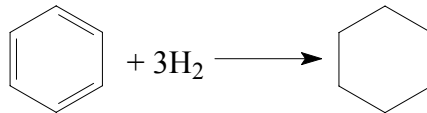


- ◆ Currently, the major route to malefic anhydride is the oxidation of butane (Chapter 6).
- ◆ Malefic anhydride also comes from oxidation of n-butenes. Properties and chemicals derived from malefic anhydride are noted in Chapter 9.

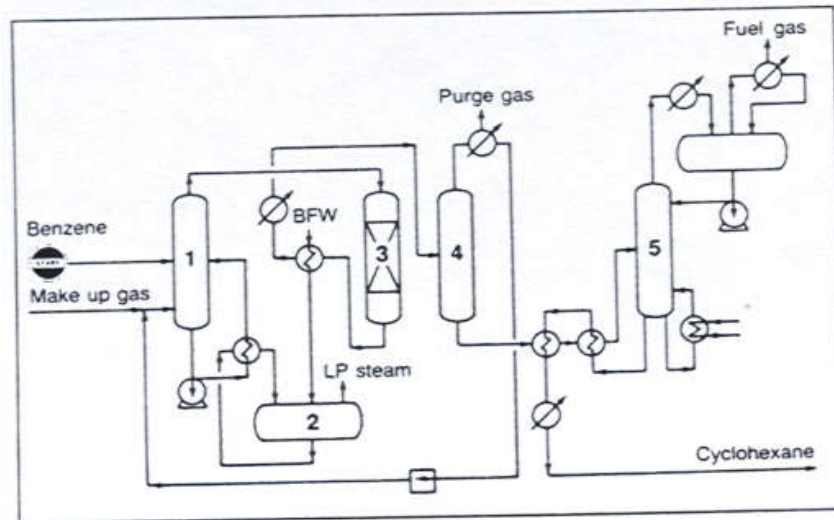
## HYDROGENATION OF BENZENE



- ◆ The hydrogenation of benzene produces cyclohexane. Many catalyst systems, such as Ni/alumina and Ni/Pd, are used for the reaction.
- ◆ General reaction conditions are 160-220°C and 25-30 atmospheres. Higher temperatures and pressures may also be used with sulfided catalysts:



- ◆ Older methods use a liquid phase process (Figure 10-11). New gas-phase processes operate at higher temperatures with noble metal catalysts.
- ◆ Using high temperatures accelerates the reaction (faster rate). The hydrogenation of benzene to cyclohexane is characterized by a highly exothermic reaction and a significant decrease in the product volume (from 4 to 1).
- ◆ Equilibrium conditions are therefore strongly affected by temperature and pressure.
- ◆ Figure 10-12 shows the effect of HZ/benzene mole ratio on the benzene content in the products. It is clear that benzene content in the product decreases with an increase of the reactor inlet pressure.



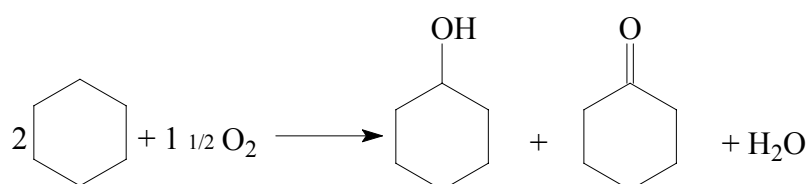
**Figure 10-11.** The Institut Francais du Petrole Process for the hydrogenation of benzene to cyclohexane: (1) liquid-phase reactor, (2) heat exchanger, (3) catalytic pot (cats as a finishing reactor when conversion of the main reactor drops below the required level), (4) high-pressure separator, (5) stabilizer.

### Properties and Uses of Cyclohexane

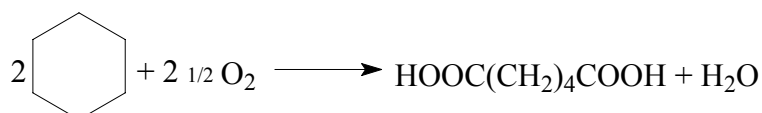
- ◆ Cyclohexane is a colorless liquid, insoluble in water but soluble in hydrocarbon solvents, alcohol, and acetone.
- ◆ As a cyclic paraffin, it can be easily dehydrogenated to benzene. The dehydrogenation of cyclohexane and its derivatives (present in naphthas) to aromatic hydrocarbons is an important reaction in the catalytic reforming process.
- ◆ Essentially, all cyclohexane is oxidized either to a cyclohexanone-cyclohexanol mixture used for making caprolactam or to adipic acid. These are monomers for making nylon 6 and nylon 6/6.

***Oxidation of Cyclohexane  
(Cyclohexanone-Cyclohexanol and Adipic Acid)***

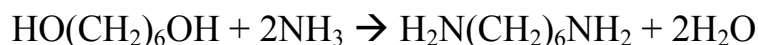
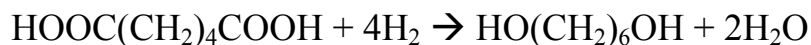
- ◆ Cyclohexane is oxidized in a liquid-phase process to a mixture of cyclohexanone and cyclohexanol (KA oil).
- ◆ The reaction conditions are 95-120°C at approximately 10 atmospheres in the presence of a cobalt acetate and orthoboric acid catalyst system. About 95% yield can be obtained:



- ◆ KA oil is used to produce caprolactam, the monomer for nylon 6.
- ◆ Caprolactam is also produced from toluene through the intermediate formation of cyclohexane carboxylic acid.
- ◆ Cyclohexane is also a precursor for adipic acid. Oxidizing cyclohexane in the liquid-phase at lower temperatures and for longer residence times (than for KA oil) with a cobalt acetate catalyst produces adipic acid:



- ◆ Adipic acid and its esters are used to make nylon 6/6. It may also be hydrogenated to 1,6-hexanediol, which is further reacted with ammonia to hexamethylenediamine.



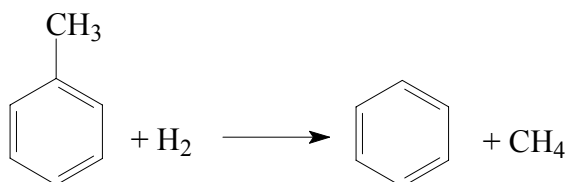
- ◆ Hexamethylenediamine is the second monomer for nylon 6/6.

## REACTIONS AND CHEMICALS OF TOLUENE

- ◆ Toluene (methylbenzene) is similar to benzene as a mononuclear aromatic, but it is more active due to presence of the electron-donating methyl group.
- ◆ However, toluene is much less useful than benzene because it produces more polysubstituted products.
- ◆ Most of the toluene extracted for chemical use is converted to benzene via dealkylation or disproportionation.
- ◆ The rest is used to produce a limited number of petrochemicals. The main reactions related to the chemical use of toluene (other than conversion to benzene) are the oxidation of the methyl substituent and the hydrogenation of the phenyl group.
- ◆ Electrophilic substitution is limited to the nitration of toluene for producing mononitrotoluene and dinitrotoluenes. These compounds are important synthetic intermediates.

### DEALKYLATION OF TOLUENE

- ◆ Toluene is dealkylated to benzene over a hydrogenation-dehydrogenation catalyst such as nickel.
- ◆ The hydrodealkylation is essentially a hydrocracking reaction favored at higher temperatures and pressures.
- ◆ The reaction occurs at approximately 700°C and 40 atmospheres. A high benzene yield of about 96% or more can be achieved:

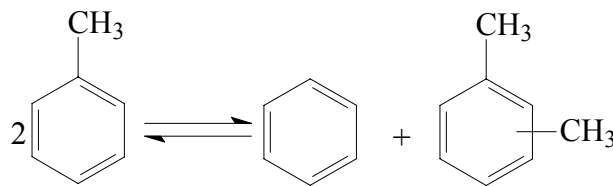


- ◆ Dealkylation also can be effected by steam. The reaction occurs at 600-800°C over Y, La, Ce, Pr, Nd, Sm, or Th compounds, Ni-Cr<sub>2</sub>O<sub>3</sub> catalysts, and Ni-Al<sub>2</sub>O<sub>3</sub> catalysts at temperatures between 320-630°C. Yields of about 90% are obtained. This process has the advantage of producing, rather than using, hydrogen.

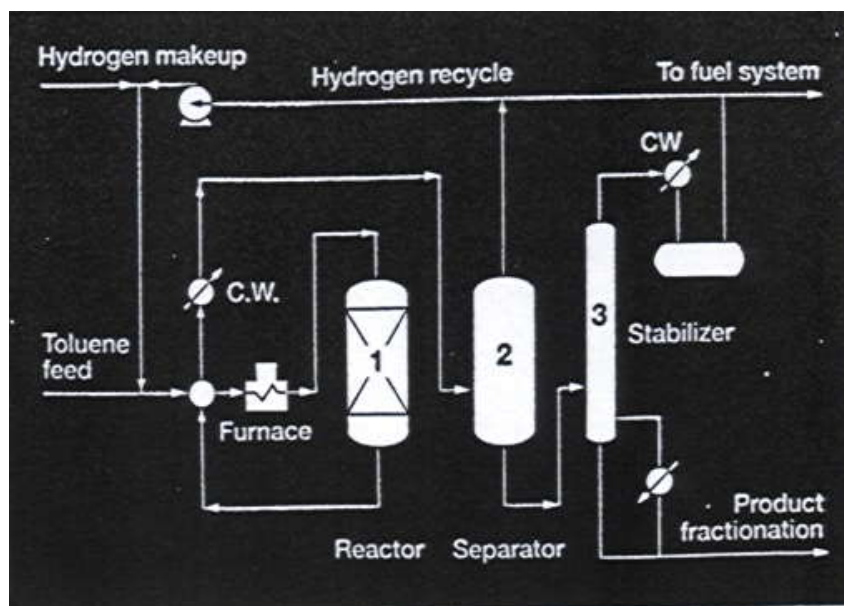


## DISPROPORTIONATION OF TOLUENE

- ◆ The catalytic disproportionation of toluene in the presence of hydrogen produces benzene and a xylene mixture. Disproportionation is an equilibrium reaction with a 58% conversion per pass theoretically possible.
- ◆ The reverse reaction is the transalkylation of xylenes with benzene:

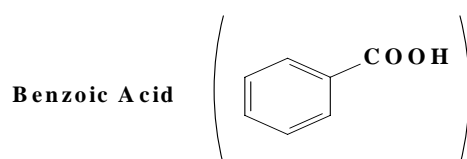


- ◆ Typical conditions for the disproportionation reaction are 450-530°C and 20 atmospheres. A mixture of CoO-MoO<sub>3</sub> on aluminosilicates or alumina catalysts can be used.
- ◆ Conversions of approximately 40% are normally used to avoid more side reactions and faster catalyst deactivation.
- ◆ The equilibrium constants for this reaction are not significantly changed by shifting from liquid to vapor phase or by large temperature changes.
- ◆ Currently, zeolites, especially those of ZSM-5 type, are preferred for their higher activities and selectivities. They are also more stable thermally.
- ◆ Modifying ZSM-5 zeolites with phosphorous, boron, or magnesium compounds produces xylene mixtures rich in the p-isomer (70-90%).
- ◆ It has been proposed that the oxides of these elements, present in zeolites, reduce the dimensions of the pore openings and channels and so favor formation and outward diffusion of p-xylene, the isomer with the smallest minimum dimension.

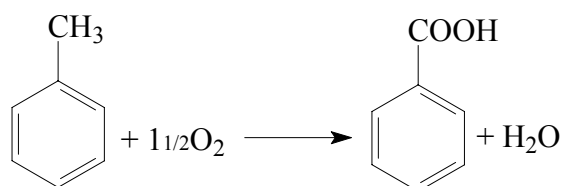


**Figure 10-13.** The Mobil Oil Corp, IFP process for the disproportionation of toluene to mixed xylenes.

## OXIDATION OF TOLUENE



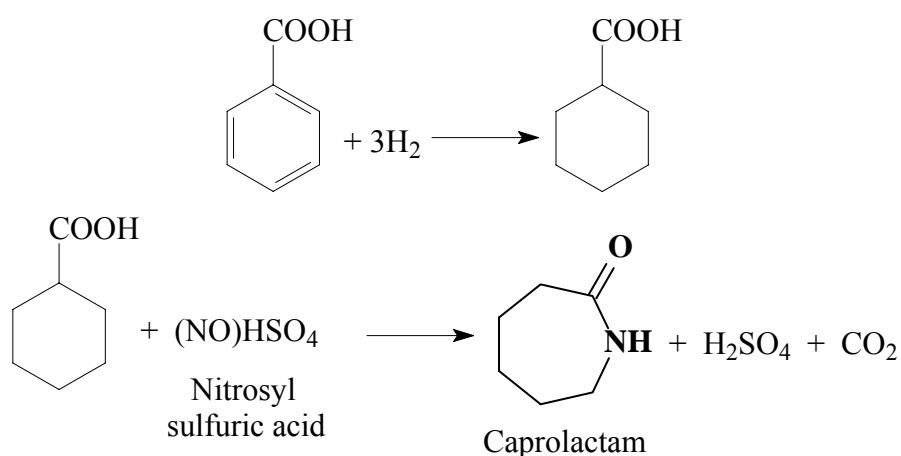
- ◆ Oxidizing toluene in the liquid phase over a cobalt acetate catalyst produces benzoic acid. The reaction occurs at about 165°C and 10 atmospheres. The yield is over 90%:



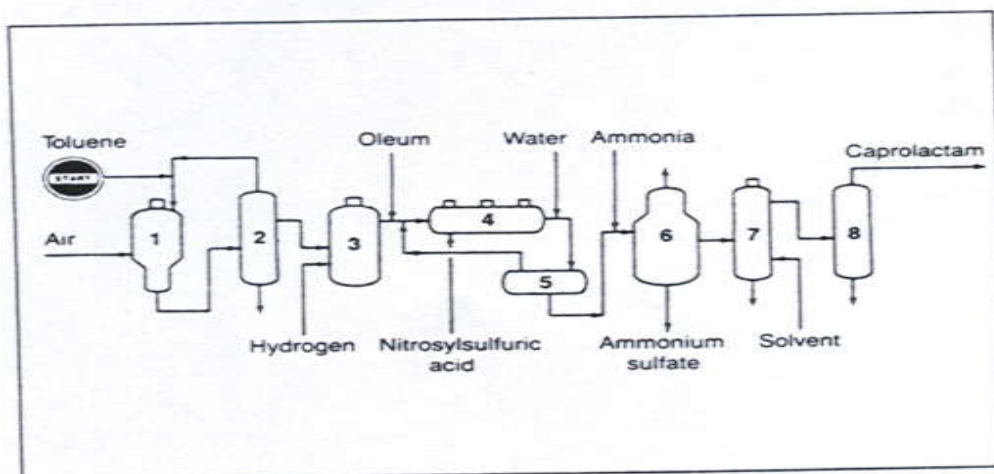
- ◆ Benzoic acid (benzene carboxylic acid) is a white crystalline solid with a characteristic odor. It is slightly soluble in water and soluble in most common organic solvents.
- ◆ Though much benzoic acid gets used as a mordant in calico printing, it also serves to season tobacco, preserve food, make dentifrices, and kill fungus. Furthermore it is a precursor for caprolactam, phenol, and terephthalic acid.

## Caprolactam Production

- ◆ Caprolactam, a white solid that melts at 69°C, can be obtained either in a fused or flaked form. It is soluble in water, ligroin, and chlorinated hydrocarbons.
- ◆ Caprolactam's main use is to produce nylon 6. Other minor uses are as a crosslinking agent for polyurethanes, in the plasticizer industry, and in the synthesis of lysine.
- ◆ The first step in producing caprolactam from benzoic acid is its hydrogenation to cyclohexane carboxylic acid at approximately 170°C and 16 atmospheres over a palladium catalyst:



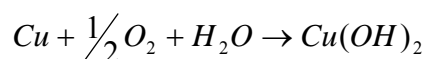
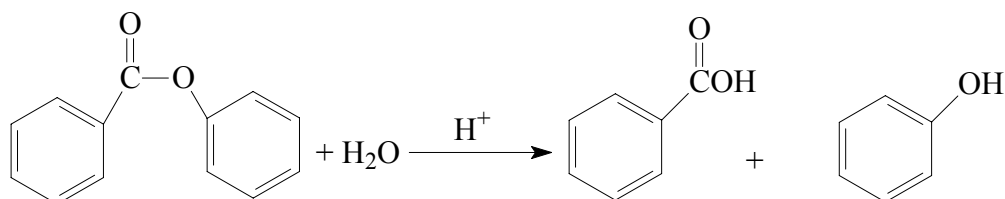
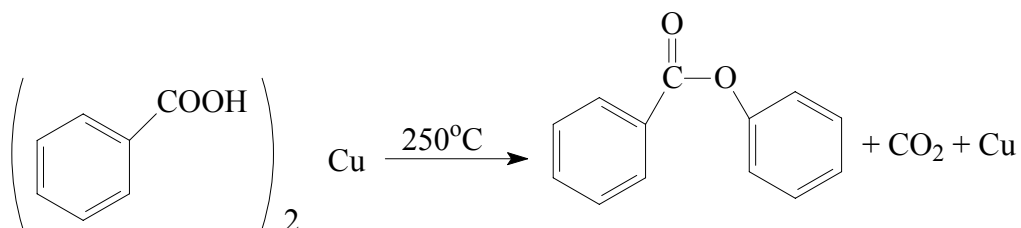
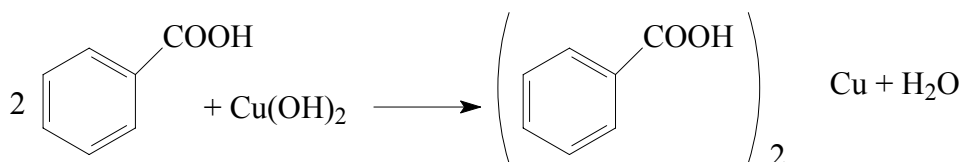
- ◆ The resulting acid is then converted to caprolactam through a reaction with nitrosyl-sulfuric acid:
- ◆ Toluene, the feed, is first oxidized to benzoic acid.
- ◆ Benzoic acid is then hydrogenated to cyclohexane carboxylic acid, which reacts with nitrosylsulfuric acid yielding caprolactam. Nitrosyl sulfuric acid comes from reacting nitrogen oxides with oleum.
- ◆ Caprolactam comes as an acidic solution that is neutralized with ammonia and gives ammonium sulfate as a by-product of commercial value. Recovered caprolactam is purified through solvent extraction and fractionation.



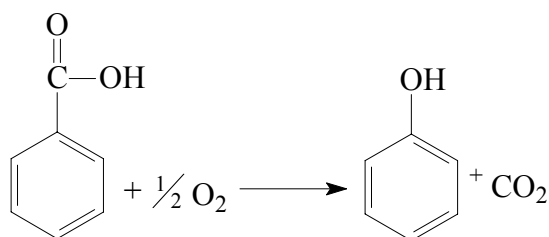
**Figure 10-14.** The SNIA BPD process for producing caprolactam. (1) toluene oxidation reactor, (2) fractionator, (3) hydrogenation reactor (stirred autoclave), (4) multistage reactor (conversion to caprolactam), (5) water dilution, (6) crystallizer, (7) solvent extraction, (8) fractionator.

### *Phenol from Benzoic Acid*

- ◆ The action of a copper salt converts benzoic acid to phenol. The copper, reoxidized by air, functions as a real catalyst. The Lummus process operates in the vapor phase at approximately 250°C. Phenol yield of 90% is possible:



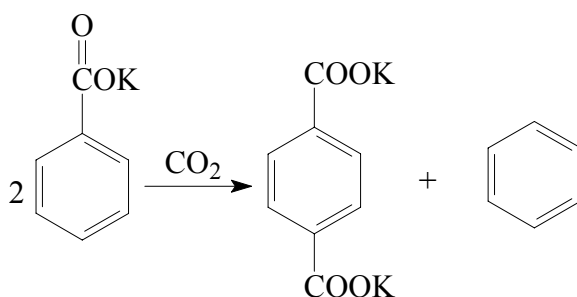
The overall reaction is



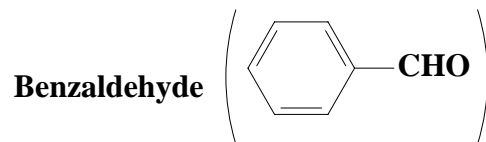
- ◆ Phenol can also be produced from chlorobenzene and from cumene, the major route for this commodity.

### *Terephthalic Acid from Benzoic Acid*

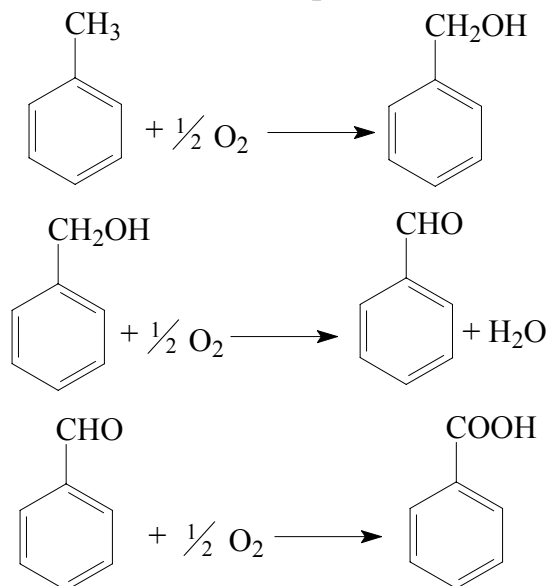
- ◆ Terephthalic acid is an important monomer for producing polyesters.
- ◆ The main route for obtaining the acid is the catalyzed oxidation of paraxylene.
- ◆ It can also be produced from benzoic acid by a disproportionation reaction of potassium benzoate in the presence of carbon dioxide. Benzene is the coproduct:



- ◆ The reaction occurs in a liquid-phase process at approximately 400°C using ZnO or CdO catalysts.
- ◆ Terephthalic acid is obtained from an acid treatment; the potassium salt is recycled.



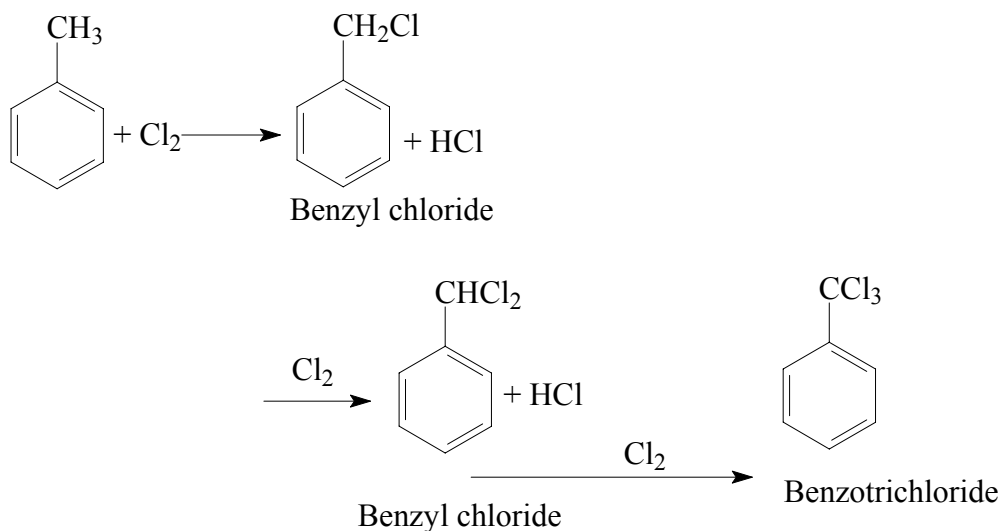
- ◆ Oxidizing toluene to benzaldehyde is a catalyzed reaction in which a selective catalyst limits further oxidation to benzoic acid. In the first step, benzyl alcohol is formed and then oxidized to benzaldehyde. Further oxidation produces benzoic acid:



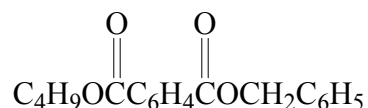
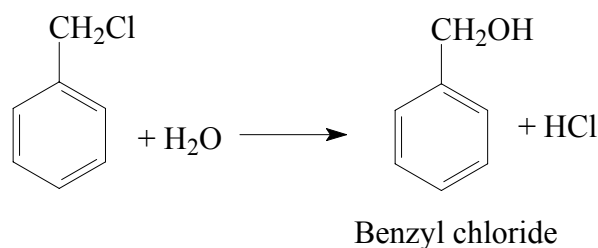
- ◆ The problem with this reaction is that each successive oxidation occurs more readily than the preceding one (more acidic hydrogens after introducing the oxygen hetero atom, which facilitates the oxidation reaction to occur).
- ◆ In addition to using a selective catalyst, the reaction can be limited to the production of the aldehyde by employing short residence times and a high toluene-to-oxygen ratio.
- ◆ In one process, a mixture of  $\text{UO}_2$  (93%) and  $\text{MnO}_2$  (7%) is the catalyst. A yield of 30-50% could be obtained at low conversions of 10-20%.
- ◆ The reaction temperature is approximately  $500^\circ\text{C}$ . In another process, the reaction goes forward in the presence of methanol over an  $\text{FeBr}_2$ - $\text{CoBr}_2$  catalyst mixture at approximately  $100$ - $140^\circ\text{C}$ .
- ◆ Benzaldehyde has limited uses as a chemical intermediate. It is used as a solvent for oils, resins, cellulose esters, and ethers. It is also used in flavoring compounds and in synthetic perfumes.

## CHLORINATION OF TOLUENE

- ◆ The chlorination of toluene by substituting the methyl hydrogens is a free radical reaction. A mixture of three chlorides (benzyl chloride, benzal chloride and benzotrichloride) results.



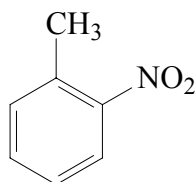
- ◆ The ratio of the chloride mixture mainly derives from the toluene/chlorine ratio and the contact time.
- ◆ Benzyl chloride is produced by passing dry chlorine into boiling toluene (110°C) until reaching a density of 1.283.
- ◆ At this density, the concentration of benzyl chloride reaches the maximum. Light can initiate the reaction.
- ◆ Benzyl chloride can produce benzyl alcohol by hydrolysis:



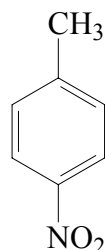
- ◆ Benzyl alcohol is a precursor for butylbenzyl phthalate, a vinyl chloride plasticizer. Benzyl chloride is also a precursor for phenylacetic acid via the intermediate benzyl cyanide. Phenylacetic acid is used to make phenobarbital (a sedative) and penicillin G.
- ◆ Benzal chloride is hydrolyzed to benzaldehyde, and benzotrichloride is hydrolyzed to benzoic acid.
- ◆ Chlorinated toluenes are not large-volume chemicals, but they are precursors for many synthetic chemicals and pharmaceuticals.

### NITRATION OF TOLUENE

- ◆ The nitration reaction occurs with an electrophilic substitution by the nitronium ion.
- ◆ The reaction conditions are milder than those for benzene due to the activation of the ring by the methyl substituent.
- ◆ A mixture of nitrotoluenes results. The two important monosubstituted nitrotoluenes are o- and p-nitrotoluenes:

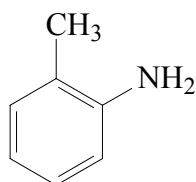


o-Nitrotoluene

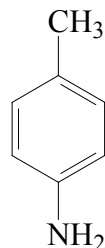


p-Nitrotoluene

- ◆ Mononitrotoluenes are usually reduced to corresponding toluidines, which make dyes and rubber chemicals:



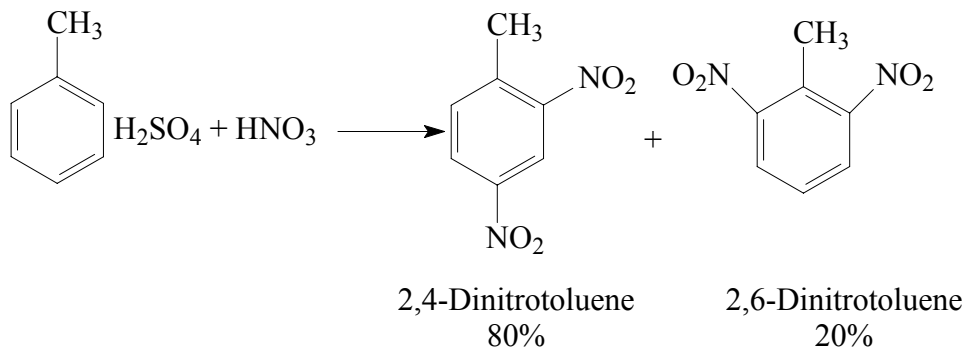
o-Toluidine



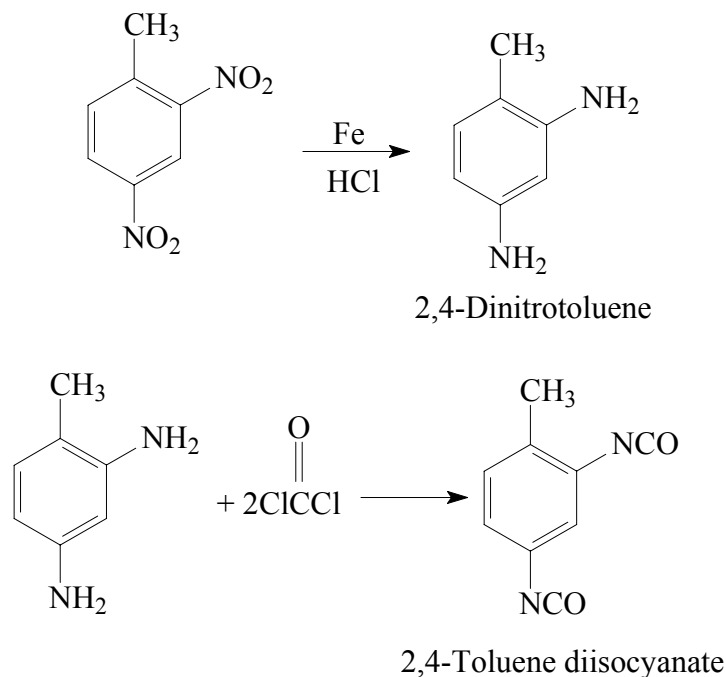
p-Toluidine



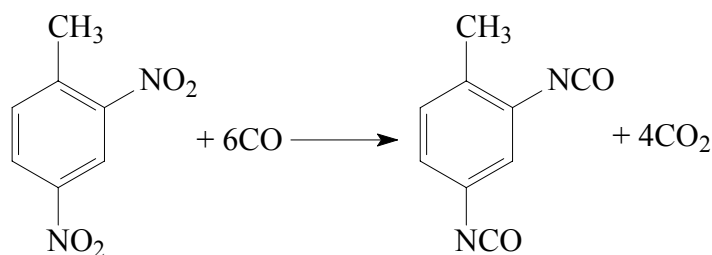
- ◆ Dinitrotoluenes are produced by nitration of toluene with a mixture of concentrated nitric and sulfuric acid at approximately 80°C. The main products are 2,4- and 2,6-dinitrotoluenes:



- ◆ The dinitrotoluenes are important precursors for toluene diisocyanates (TDI), monomers used to produce polyurethanes.
- ◆ The TDI mixture is synthesized from dinitrotoluenes by a first-step hydrogenation to the corresponding diamines.
- ◆ The diamines are then treated with phosgene to form TDI. The yield from toluene is approximately 85%:



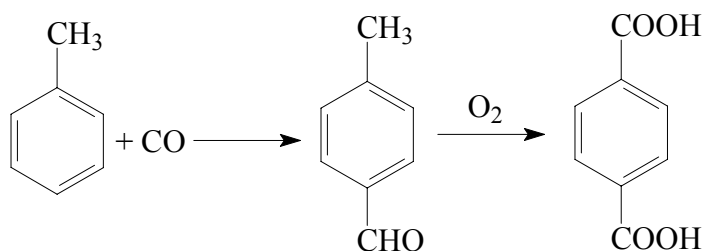
- ◆ An alternative route for TDI is through a liquid-phase carbonylation of dinitrotoluene in presence of PdCl<sub>2</sub> catalyst at approximately 250°C and 200 atmospheres:



- ◆ Trinitrotoluene TNT is a well-known explosive obtained by further nitration of the dinitrotoluenes.

### CARBONYLATION OF TOLUENE

- ◆ The carbonylation reaction of toluene with carbon monoxide in the presence of HF/BF<sub>3</sub> catalyst produces *p*-tolualdehyde.
- ◆ A high yield results (96% based on toluene and 98% based on CO). *p*-Tolualdehyde could be further oxidized to terephthalic acid, an important monomer for polyesters:



- ◆ *p*-Tolualdehyde is also an intermediate in the synthesis of perfumes, dyes and pharmaceuticals:

## CHEMICALS FROM XYLENES

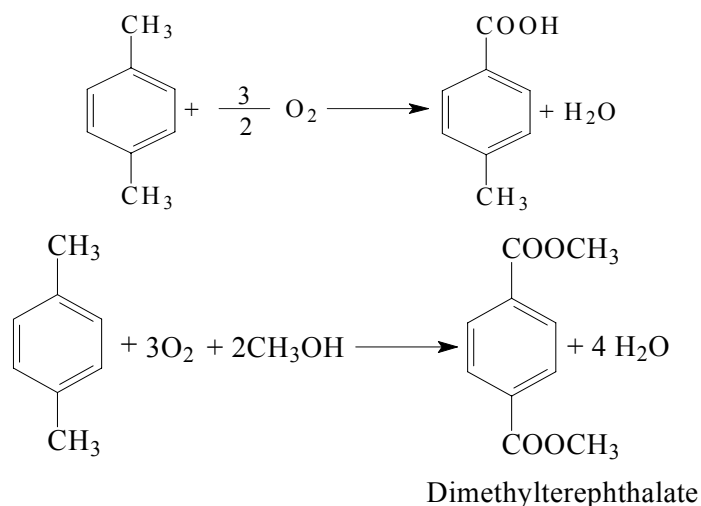
- ◆ Xylenes (dimethylbenzenes) are an aromatic mixture composed of three isomers (*o*-, *m*-, and *p*-xylene).
- ◆ They are normally obtained from catalytic reforming and cracking units with other C<sub>6</sub>, C<sub>7</sub>, and C<sub>8</sub> aromatics.
- ◆ Separating the aromatic mixture from the reformat is done by extraction-distillation and isomerization processes (Chapter 2).
- ◆ *para*-Xylene is the most important of the three isomers for producing terephthalic acid to manufacture polyesters.
- ◆ *m*-Xylene is the least used of the three isomers, but the equilibrium mixture obtained from catalytic reformers has a higher ratio of the meta isomer. *m*-Xylene is usually isomerized to the more valuable *p*-xylene.
- ◆ As mentioned earlier, xylene chemistry is primarily related to the methyl substituents, which are amenable to oxidation.
- ◆ Approximately 65% of the isolated xylenes are used to make chemicals. The rest are either used as solvents or blended with gasolines.

**Table 10-3. Thermodynamic equilibrium composition of C<sub>8</sub> aromatics at three temperatures**

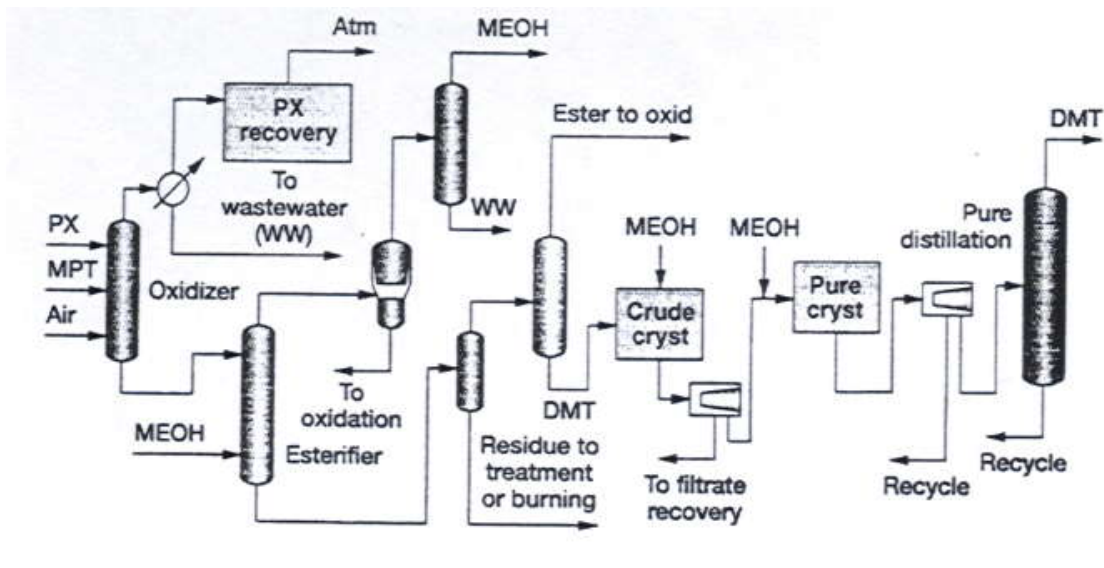
Aromatics wt%	Composition		
	200°C	300 °C	500 °C
<i>p</i> -Xylene	21.8	21.1	18.9
<i>o</i> -Xylene	20.6	21.6	23.0
<i>m</i> -Xylene	53.5	51.1	47.1
ethylbenzene	4.1	6.2	11.0

## TEREPHTHALIC ACID (HOOC<sub>6</sub>H<sub>4</sub>COOH)

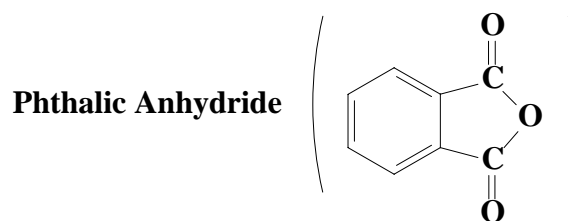
- ◆ The catalyzed oxidation of *p*-xylene produces terephthalic acid (TPA). Cobalt acetate promoted with either NaBr or HBr is used as a catalyst in an acetic acid medium.
- ◆ Reaction conditions are approximately 200°C and 15 atmospheres. The yield is about 95%:



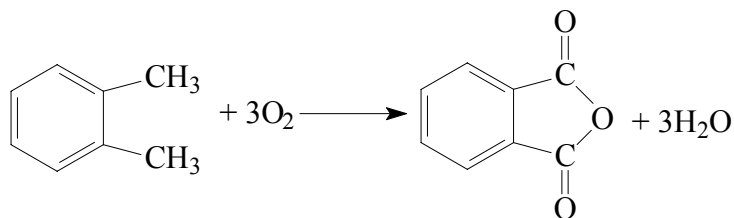
- ◆ Special precautions must be taken so that the reaction does not stop at the *p*-toluic acid stage.
- ◆ One approach is to esterify toluic acid as it is formed with methanol. This facilitates the oxidation of the second methyl group.
- ◆ The resulting dimethyl terephthalate (DMT) may be hydrolyzed to terephthalic acid.
- ◆ Another approach is to use an easily oxidized substance such as acetaldehyde or methylethyl ketone, which, under the reaction conditions, forms a hydroperoxide.
- ◆ These will accelerate the oxidation of the second methyl group. The DMT process encompasses four major processing steps: oxidation, esterification, distillation, and crystallization.
- ◆ Figure 10-16 shows a typical *p*-xylene oxidation process to produce terephthalic acid or dimethyl terephthalate.
- ◆ The main use of TPA and DMT is to produce polyesters for synthetic fiber and film.



**Figure 10-16**, A typical p-xylene to dimethyl terephthalate

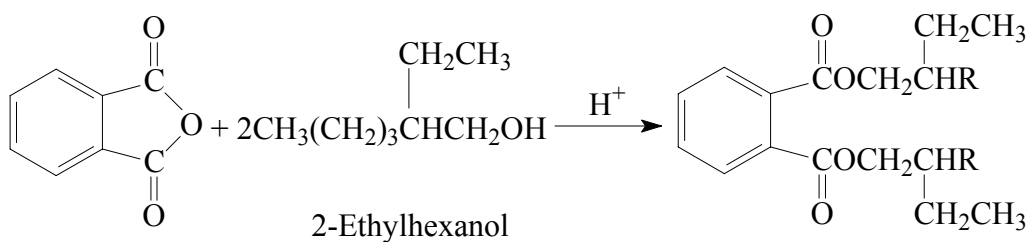


- ◆ Currently, phthalic anhydride is mainly produced through catalyzed oxidation of *o*-xylene.
- ◆ A variety of metal oxides are used as catalysts. A typical one is  $\text{V}_2\text{O}_5 + \text{TiO}_2 / \text{Sb}_2\text{O}_3$ . Approximate conditions for the vapor-phase oxidation are  $375\text{--}435^\circ\text{C}$  and 0.7 atmosphere. The yield of phthalic anhydride is about 85%:



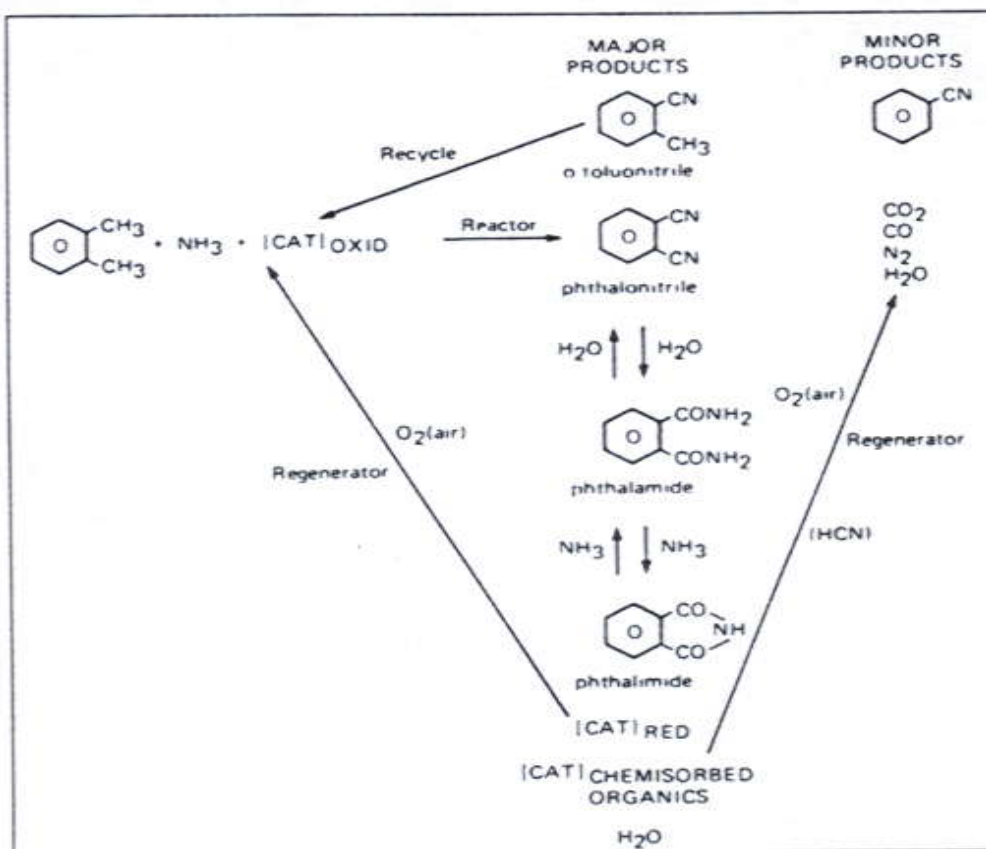
- ◆ Liquid-phase oxidation of *o*-xylene also works at approximately  $150^\circ\text{C}$ . Cobalt or manganese acetate in acetic acid medium serves as a catalyst.
- ◆ The major by-products of this process are maleic anhydride, benzoic acid, and citraconic anhydride (methylmaleic anhydride). Maleic anhydride could be recovered economically.

- ◆ Phthalic anhydride's main use is for producing plasticizers by reactions with C<sub>4</sub>-C<sub>10</sub> alcohols.
- ◆ The most important polyvinyl chloride plasticizer is formed by the reaction of 2-ethylhexanol (produced via butyraldehyde, Chapter 8) and phthalic anhydride:

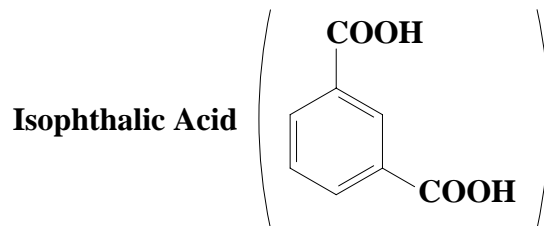


R = CH<sub>3</sub>(CH<sub>2</sub>)<sub>3</sub>-

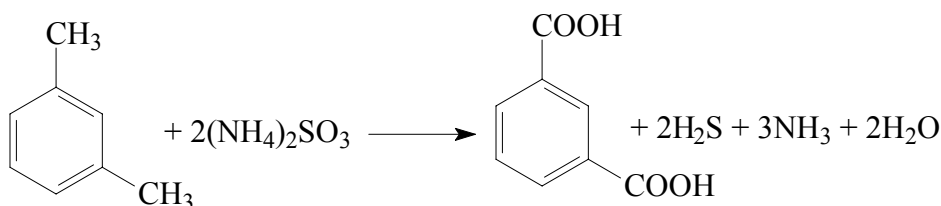
- ◆ Phthalic anhydride is also used to make polyester and alkyd resins. It is a precursor for phthalonitrile by an ammoxidation route used to produce phthalamide and phthalimide. The reaction scheme for producing phthalonitrile, phthalamide, and phthalimide is shown in Figure 10-17.



**Figure 10-17**, The reaction scheme for *o*-xylene to phthalonitrile.



- ◆ The oxidation of m-xylene produces isophthalic acid. The reaction occurs in the liquid-phase in presence of ammonium sulfite:



- ◆ Isophthalic acid's main use is for producing polyesters that are characterized by a higher abrasion resistance than those using other phthalic acids. Polyesters from isophthalic acid are used for pressure molding applications.
- ◆ Ammoxidation of isophthalic acid produces isophthalonitrile. The reaction resembles the one used for ammoxidation of phthalic anhydride:
- ◆ Isophthalonitrile serves as a precursor for agricultural chemicals. It is readily hydrogenated to the corresponding diamine, which can form polyamides or be converted to isocyanates for polyurethanes.