

Crystal Field Theory (CFT)

As originally developed, crystal field theory was used to describe the electronic structure of metal ions in crystals, where they are surrounded by oxide ions or other anions that create an electrostatic field with symmetry dependent on the crystal structure. The energies of the d orbitals of the metal ions are split by the electrostatic field, and approximate values for these energies can be calculated.

CFT was developed in 1930s. Shortly afterward, it was recognized that the same arrangement of charged or neutral electron pair donor species around a metal ion existed in crystals and coordination complexes.

In order to understand clearly the interactions that are responsible for crystal or ligand field effects in transition metal complexes, it is necessary to know the geometrical relationships of the d orbitals. There are five wave functions that can be written for orbitals having the typical four-lobed form.

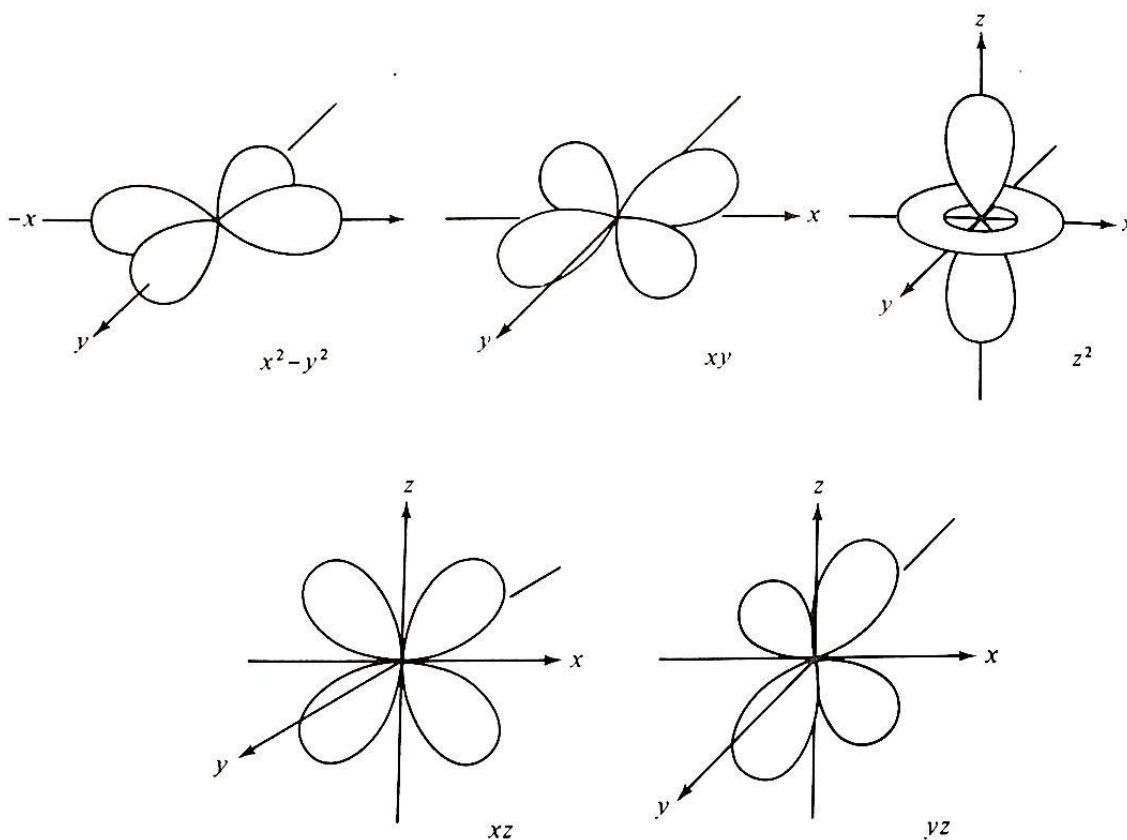

Crystal Field Effects in Octahedral Complexes

When the d orbitals of a metal ion are placed in an octahedral field of ligand electron pairs, directed at the surrounding ligands, are raised in energy. The d_{xy} , d_{xz} , and d_{yz} orbitals, which are directed between the surrounding ions, are relatively unaffected by the field. The resulting energy difference is identified as Δ_o (o for octahedral; some older references use the term $10Dq$ instead of Δ_o).

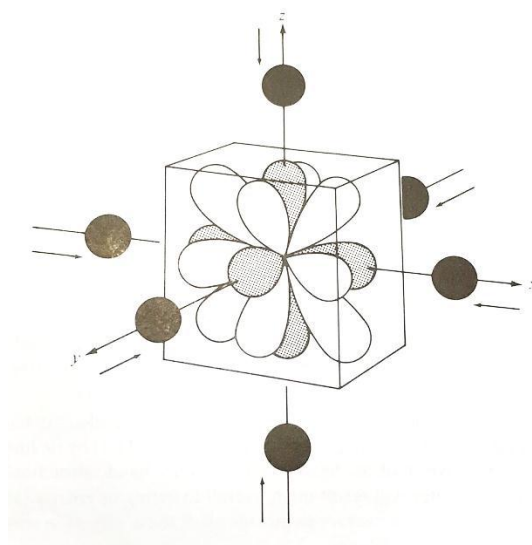

In case of free metal ion all the five d-orbitals are degenerate (these have the same energy). Now consider an octahedral complex, $[ML_6]^{n+}$ in which the central metal cation, M^{n+} is placed at the center of the octahedral and is surrounded by six ligands which reside at the six corners of the octahedral.

Now suppose both the ligands on each of the three axes are allowed to approach towards the metal cation, M^{n+} from both the ends of the axes. In this process the electrons in d-orbitals of the metal cation are repelled by the negative point charge or by the negative end of the dipole of the ligands. (Remember CFT the ionic ligands as negative point charges and neutral ligands as dipoles). This repulsion will raise the energy of all the five d-orbitals. Since the lobes of d_{z^2} and $d_{x^2-y^2}$ orbitals (eg orbitals) lie directly in the path of the approaching ligands, the electrons in these orbitals experience greater force of repulsion than those in d_{xy} , d_{yz} , and d_{zx} orbitals

(t_{2g} orbitals) whose lobes are directed in space between the path of the approaching ligands (the energy of e_g orbitals is increased while that of t_{2g} is decreased (greater the repulsion, greater the increase in energy)).

Thus we find that under the influence of approaching ligands, the five d-orbitals which were originally degenerate in free metallic cation are now split (or resolved) into two levels, t_{2g} level which is triply degenerate and is of lower energy, and e_g level which is doubly degenerate and is of higher energy.

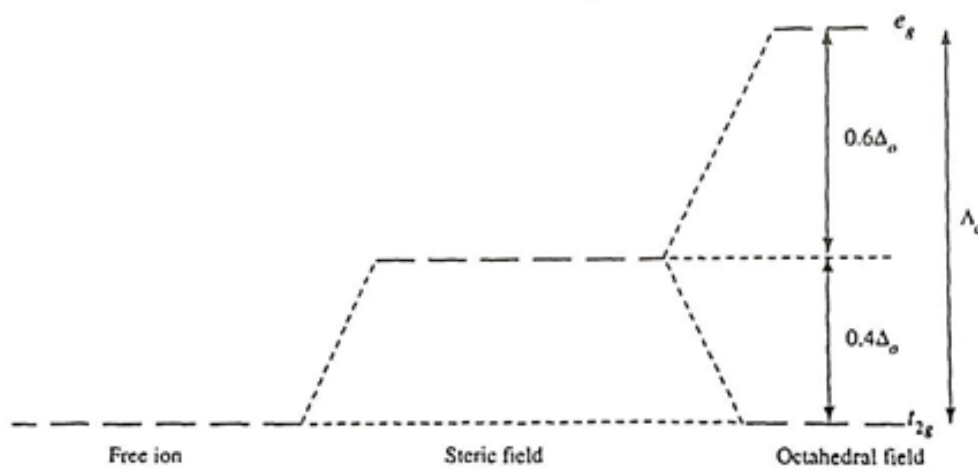

The resulting energy difference is identified as Δ_o (o for octahedral) or $10Dq$. This approach provides a simple means of identifying the d-orbital splitting found in coordination complexes and can be extended to include more quantitative calculations.

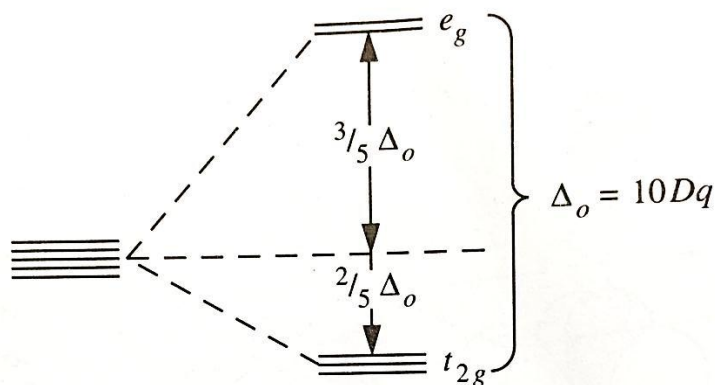

To gain some appreciation for the magnitude of Δ_o and how it may be measured, let us consider the d^1 complex, $[\text{Ti}(\text{H}_2\text{O})_6]^{3+}$. This ion exists in aqueous solution of Ti^{3+} and gives rise to a purple color. The single d electron in the complex will occupy the lowest energy orbital available to it (one of the three degenerate t_{2g} orbitals). The purple color is the result of absorption of light and promotion of the t_{2g} electron to the e_g level. The transition can be represented as $t_{2g}^1 e_g^0 \rightarrow t_{2g}^0 e_g^1$.

The absorption spectra of $[\text{Ti}(\text{H}_2\text{O})_6]^{3+}$ reveals that this transition occurs with a maximum at 20300 cm^{-1} of energy for Δ_o .

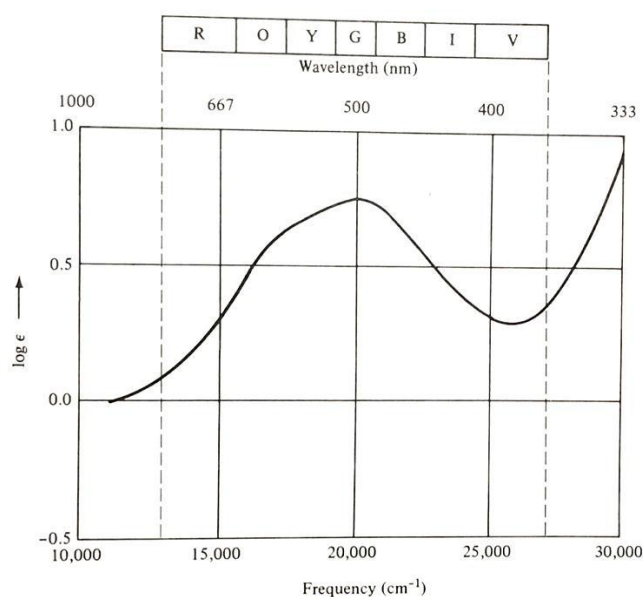

The d^1 case is the simplest possible because the observed spectral transition reflects the actual energy difference between the e_g and t_{2g} levels.

Crystal Field Stabilization Energy (CFSE)

In the d^1 case discussed above, the electron occupies a t_{2g} orbital, which has an energy of $-0.4 \Delta_o$ relative to the barycenter of the d orbitals. The complex can thus be said to be stabilized to the extent of $0.4 \Delta_o$ compared to the hypothetical spherical-field case. This quantity is termed the *crystal field stabilization energy* (CFSE).

For d^2 and d^3 metal ions, we would expect the electrons to obey Hund's rule and thus to occupy different degenerate t_{2g} orbitals and to remain unpaired. The resulting configuration, t_{2g}^2 and t_{2g}^3 , will have CFSE of $-0.8 \Delta_o$ and $-1.2 \Delta_o$ respectively.

When one more is added to form the d^4 case, two possibilities arise: either the electron may enter the higher energy e_g level or it may pair with another electron in one of the t_{2g} orbitals. The actual configuration adopted will, of course, be the lowest energy one and will depend on the relative magnitudes of Δ_o and P , the energy necessary to cause electron pairing in a single orbital.

For $\Delta_o < P$ (the weak field or high spin condition), the fourth electron will enter one of the e_g orbitals rather than of pairing with one in a t_{2g} orbital. The configuration will be $t_{2g}^3 e_g^1$ and the net CFSE will be

$$\text{CFSE} = (3 \times -0.4\Delta_o) + (1 \times +0.6\Delta_o) = -0.6 \Delta_o$$

The addition of a fifth electron to a weak field complex gives a configuration $t_{2g}^3 e_g^2$ and a CFSE of zero. The two electrons in the unfavorable e_g level exactly balance the stabilization associated with three in the t_{2g} level.

If the splitting of d orbitals is large with respect to the pairing energy ($\Delta_o > P$), it more favorable for electrons to pair in the t_{2g} level than to enter the strongly unfavorable e_g level. In these strong field or low spin complexes, the e_g level remains unoccupied for d^1 through d^6 ions. As a result, the CFSE of the complexes having four to seven d electrons will be greater for strong field than for weak field cases.

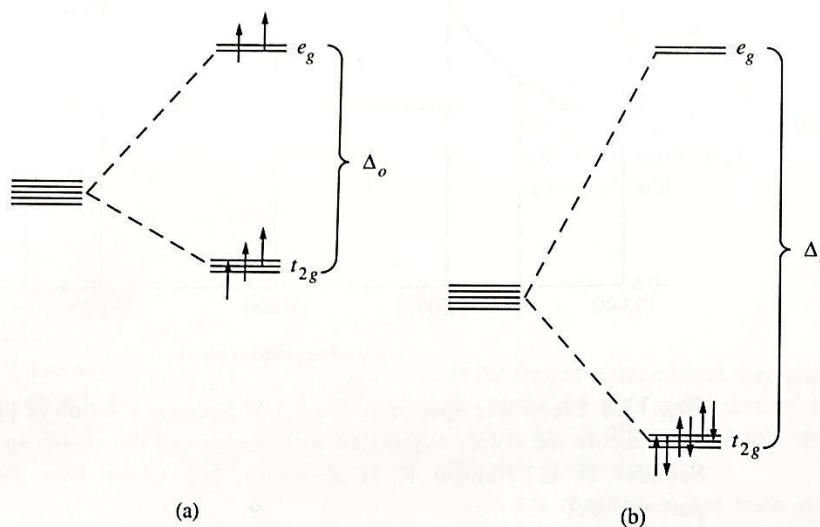

Pairing Energy (P)

The electron-pairing energy is composed of two terms. One is the coulombic repulsion that must be overcome when forcing two electrons to occupy the same orbital. The second factor of importance is the loss of exchange energy that occurs as electrons with parallel spins are forced to have the antiparallel spins. The exchange energy for a given configuration is proportional to the number of pairs of electrons having parallel spin.

Complex with Weak Field Ligands (High Spin)

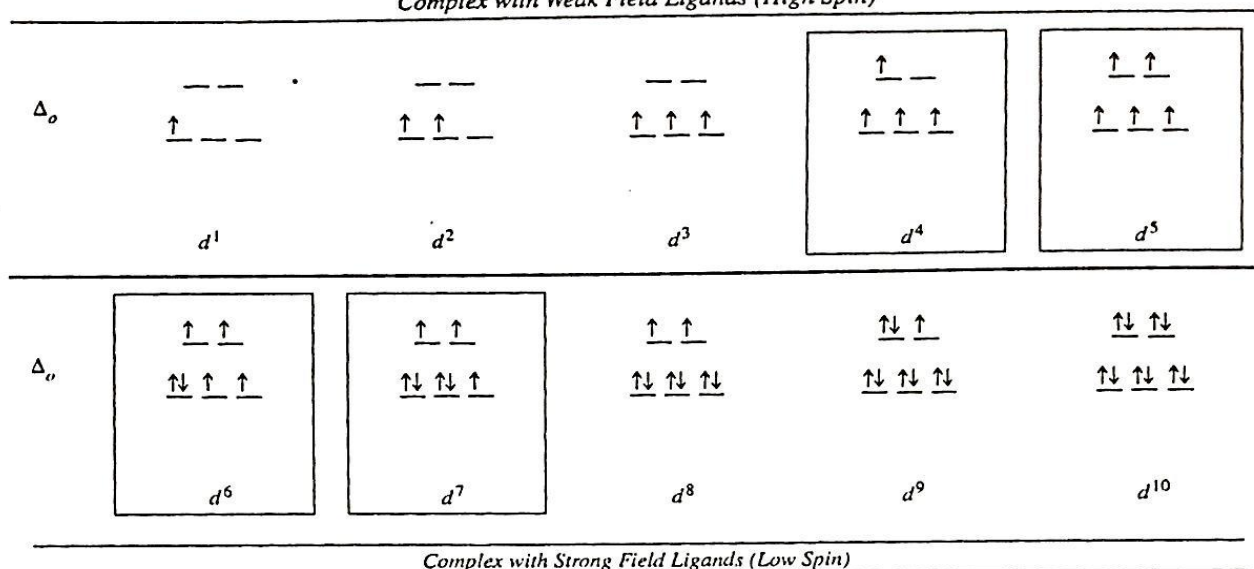

Complex with Strong Field Ligands (Low Spin)

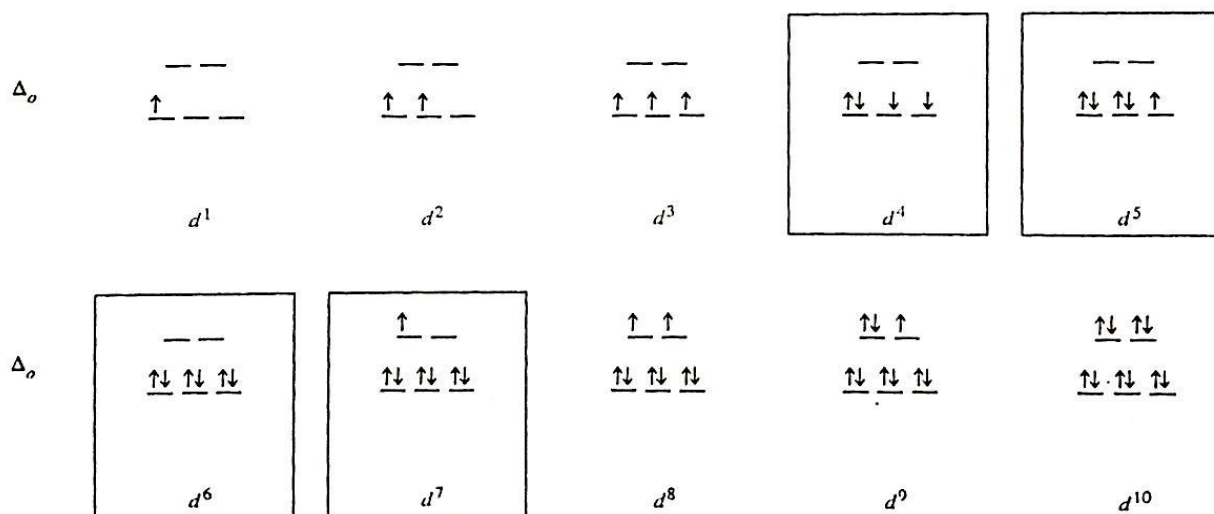

d^n configuration	Distribution of d^n electrons in t_{2g} and e_g orbitals		$t_{2g}^p e_g^q$ configuration	m	CFSE = $[-0.4p + 0.6q] \Delta_0 + mP$ = $[-0.4p + 0.6q] \times 10Dq + mP$ = $[-4p + 6q] Dq + mP$
	t_{2g}	e_g			
d^0	— — —	— —	$t_{2g}^0 e_g^0$	0	$0.0 \Delta_0 (0.0 Dq)$
d^1	\uparrow — —	— —	$t_{2g}^1 e_g^0$	0	$-0.4 \Delta_0 (-4Dq)$
d^2	$\uparrow \uparrow$ —	— —	$t_{2g}^2 e_g^0$	0	$-0.8 \Delta_0 (-8 Dq)$
d^3	$\uparrow \uparrow \uparrow$	— —	$t_{2g}^3 e_g^0$	0	$-1.2 \Delta_0 (-12 Dq)$
d^4	$\uparrow \uparrow \uparrow$	\uparrow —	$t_{2g}^3 e_g^1$	0	$-0.6 \Delta_0 (-6 Dq)$
d^5	$\uparrow \uparrow \uparrow$	$\uparrow \uparrow$	$t_{2g}^3 e_g^2$	0	$-0.0 \Delta_0 (0.0 Dq)$
d^6	$\uparrow \downarrow \uparrow \uparrow$	$\uparrow \uparrow$	$t_{2g}^4 e_g^2$	1	$-0.4 \Delta_0 (-4 Dq) + P$
d^7	$\uparrow \downarrow \uparrow \downarrow \uparrow$	$\uparrow \uparrow$	$t_{2g}^5 e_g^2$	2	$-0.8 \Delta_0 (-8 Dq) + 2P$
d^8	$\uparrow \downarrow \uparrow \downarrow \uparrow \downarrow$	$\uparrow \uparrow$	$t_{2g}^6 e_g^2$	3	$-1.2 \Delta_0 (-12Dq) + 3P$
d^9	$\uparrow \downarrow \uparrow \downarrow \uparrow \downarrow \uparrow$	$\uparrow \downarrow \uparrow$	$t_{2g}^6 e_g^3$	4	$-0.6 \Delta_0 (-6 Dq) + 4P$
d^{10}	$\uparrow \downarrow \uparrow \downarrow \uparrow \downarrow \uparrow \downarrow$	$\uparrow \downarrow \uparrow \downarrow$	$t_{2g}^6 e_g^4$	5	$0.0 \Delta_0 (0.0 Dq) + 5P$

d^n configuration	Distribution of d^n electrons in t_{2g} and e_g orbitals		$t_{2g}^p e_g^q$ configuration	m	CFSE = $[-0.4p + 0.6q] \Delta_0 + mP$ = $[0.4p + 0.6q] \times 10Dq + mP$ = $[-4p + 6q] Dq + mP$
	t_{2g}	e_g			
d^0	— — —	— —	$t_{2g}^0 e_g^0$	0	$0.0 \Delta_0 (0.0 Dq)$
d^1	\uparrow — —	— —	$t_{2g}^1 e_g^0$	0	$-0.4 \Delta_0 (-4Dq)$
d^2	$\uparrow \uparrow$ —	— —	$t_{2g}^2 e_g^0$	0	$-0.8 \Delta_0 (-8 Dq)$
d^3	$\uparrow \uparrow \uparrow$	— —	$t_{2g}^3 e_g^0$	0	$-1.2 \Delta_0 (-12 Dq)$
d^4	$\uparrow \downarrow \uparrow \uparrow$	— —	$t_{2g}^4 e_g^0$	1	$-1.6 \Delta_0 (-16 Dq) + P$
d^5	$\uparrow \downarrow \uparrow \downarrow \uparrow$	— —	$t_{2g}^5 e_g^0$	2	$-2.0 \Delta_0 (-20 Dq) + 2P$
d^6	$\uparrow \downarrow \uparrow \downarrow \uparrow \downarrow$	— —	$t_{2g}^6 e_g^0$	3	$-2.4 \Delta_0 (-24 Dq) + 3P$
d^7	$\uparrow \downarrow \uparrow \downarrow \uparrow \downarrow \uparrow$	\uparrow —	$t_{2g}^6 e_g^1$	3	$-1.8 \Delta_0 (-18 Dq) + 3P$
d^8	$\uparrow \downarrow \uparrow \downarrow \uparrow \downarrow \uparrow \downarrow$	$\uparrow \uparrow$	$t_{2g}^6 e_g^2$	3	$-1.2 \Delta_0 (-12Dq) + 3P$
d^9	$\uparrow \downarrow \uparrow \downarrow \uparrow \downarrow \uparrow \downarrow \uparrow$	$\uparrow \downarrow \uparrow$	$t_{2g}^6 e_g^3$	4	$-0.6 \Delta_0 (-6 Dq) + 4P$
d^{10}	$\uparrow \downarrow \uparrow \downarrow \uparrow \downarrow \uparrow \downarrow \uparrow \downarrow$	$\uparrow \downarrow \uparrow \downarrow$	$t_{2g}^6 e_g^4$	5	$0.0 \Delta_0 (0.0 Dq) + 5P$

Factors Affecting the Magnitude of Δ

1- Oxidation state of the metal ion

The magnitude of Δ increases with increasing ionic charge on the central metal ion.

The cations from atoms of the same transition series and having the same oxidation state have almost the same value of Δ but the cation with a higher oxidation state has a larger value of Δ than that with lower oxidation state

$$\Delta_o \text{ for } [\text{Fe}(\text{H}_2\text{O})_6]^{2+} = 10,400 \text{ cm}^{-1} \dots\dots\dots 3d^6$$

$$\Delta_o \text{ for } [\text{Fe}(\text{H}_2\text{O})_6]^{3+} = 13,700 \text{ cm}^{-1} \dots\dots\dots 3d^5$$

$$\Delta_o \text{ for } [\text{Co}(\text{H}_2\text{O})_6]^{2+} = 9,300 \text{ cm}^{-1} \dots\dots\dots 3d^7$$

$$\Delta_o \text{ for } [\text{Co}(\text{H}_2\text{O})_6]^{3+} = 18,200 \text{ cm}^{-1} \dots\dots\dots 3d^6$$

This effect is probably due to the fact that the central ion with higher oxidation state (higher charge) will polarize the ligands more effectively and thus the ligands would approach such a cation more closely than they can do the cation of lower oxidation state, resulting in larger splitting.

2- Nature of the metal ion

Significant differences in Δ also occur for analogous complexes within a given group, the trend being $3d < 4d < 5d$.

In progressing from Cr to Mo or Co to Rh, the value of Δ increases by as much as 50%. Likewise, the values for Ir complexes are some 25% greater than for Rh complexes.

$$\Delta_o \text{ for } [\text{Co}(\text{NH}_3)_6]^{3+} = 23,000 \text{ cm}^{-1} \dots\dots\dots 3d^6$$

$$\Delta_o \text{ for } [\text{Rh}(\text{NH}_3)_6]^{3+} = 34,000 \text{ cm}^{-1} \dots\dots\dots 4d^6$$

$$\Delta_o \text{ for } [\text{Ir}(\text{NH}_3)_6]^{3+} = 41,000 \text{ cm}^{-1} \dots\dots\dots 5d^6$$

An important result of this trend is that complexes of the second and third transition series have a much greater tendency to be low spin than do complexes of the first transition series.

3- Number and geometry of the ligands

The point-charge model predicts that Δ for a tetrahedral complex will be only about 50% as large as for an octahedral complex, all other factors being equal. This

approximate relationship is observed for VCl_4 and $[VCl_6]^{2-}$, as well as for $[Co(NH_3)_4]^{2+}$ and $[Co(NH_3)_6]^{2+}$. (The crystal field splitting in a tetrahedral field is smaller than that in an octahedral field. For the same metal ion, ligands and metal-ligand distances, ($\Delta_t = 4/9 \Delta_o$.)

4- Nature of the ligands

The magnitude of Δ varies from strong to weak ligands. Strong ligands are those which exert a strong field on the central metal ion and hence have higher splitting power consequently relatively lower splitting power. Thus strong ligands (e.g. CN^-) give larger value of Δ and weak ligands (e.g. F^-) yield a smaller value of Δ .

Based on similar data of the absorption spectra for a wide variety of complexes, it is possible to list ligands in order of increasing field strength in a spectrochemical series.

The common ligands can be arranged in the order of their increasing splitting power to cause d-splitting. This series called *spectrochemical series*.

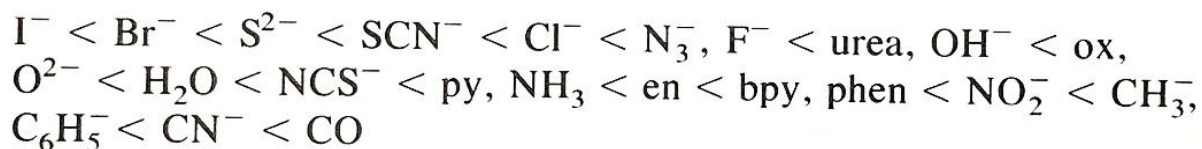

This series shows that the value of Δ in the series also increases from left to right.

The order of field strength of the common ligands shown above is independent of the nature of the central metal ion and the geometry of the complex.

Although the spectrochemical series and other trends described in this section allow one to rationalized differences in spectra and permit some predictability, they present serious difficulties in interpretation for crystal field theory. If the splitting of the d orbitals resulted simply from the effect of point charges (ions or dipoles), one should expect that anionic ligands would exert the greatest effect. To the contrary, most anionic ligands lie at the low end of the spectrochemical series. Furthermore, OH^- lies below the neutral H_2O molecule and NH_3 produces a greater splitting than H_2O , although the dipole moment in the reverse order

These apparent weaknesses in the theory called into question the assumption of purely electrostatic interactions between ligands and central metal ions and led eventually to the development of bonding description that include covalent interactions between ligands and metal.

CFT for Tetrahedral Complexes

Let us consider a tetrahedral complex ion, $[ML_4]^{n+}$ in which the central metal ion (M^{n+}) is surrounded by four ligands.

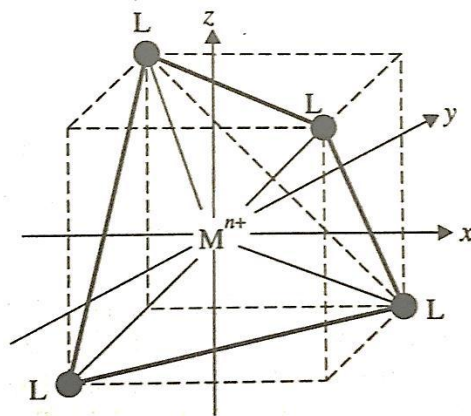

A tetrahedron may be supposed to have been formed from a cube. The center of the cube is the center of the tetrahedron at which is placed the central metal ion (M^{n+}). Four alternate corners of the cube are the four corners of the tetrahedron at which the four ligands, L are placed. The four ligands are lying between the three axes x,y and z which pass through the centers of the six faces of the cube and thus go through the center of the cube. Now since the lobes of t_2 orbitals (d_{xy} , d_{yz} and d_{zx}) are lying between the axes (are lying directly in the path of the ligands), these orbitals will experience greater force of repulsion from the ligands than those of e orbitals (d_z^2 and $d_{x^2-y^2}$) whose lobes are lying along axes (are lying in space between the ligands).

Thus the energy of t_2 orbitals will be increased while that of e orbitals will be decreased. Consequently the d orbitals are again split into two sets.

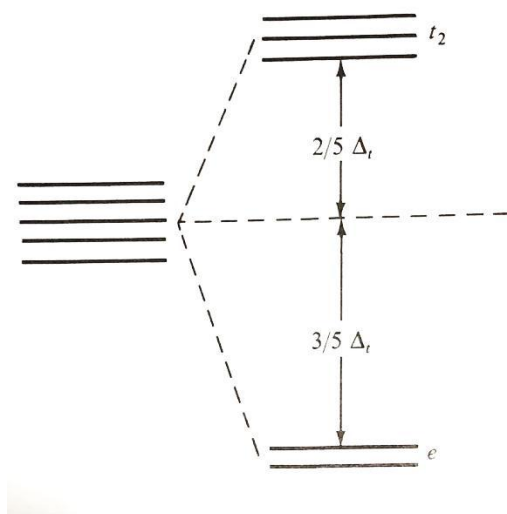

The energy difference between t_2 and e sets for tetrahedral complex is represented as Δ_t

The crystal field splitting in a tetrahedral field is smaller than that in an octahedral field because in an octahedral complex there is a ligand along each axis and in a tetrahedral complex no ligand lies directly along any axis. For this reason and also because there are only four ligands in the tetrahedral complex, while in an octahedral complex there are six ligands, the tetrahedral orbital splitting, Δ_t is less than Δ_o for the same metal ion, ligands and metal-ligand distances,

$$\Delta_t = \frac{4}{9} \Delta_o$$

As a result, orbital splitting energies in tetrahedral complexes generally are not large enough to force electrons to pair, and low spin configurations are rarely observed.

d^n ions	Distribution of d^n electrons in e and t_2 orbitals		$e^p t_2^q$ configuration
	e (Lower energy)	t_2 (Higher energy)	
d^1	\uparrow —	— — —	$e^1 t_2^0$
d^2	\uparrow \uparrow	— — —	$e^2 t_2^0$
d^3	\uparrow \uparrow	\uparrow — —	$e^2 t_2^1$
d^4	\uparrow \uparrow	\uparrow \uparrow —	$e^2 t_2^2$
d^5	\uparrow \uparrow	\uparrow \uparrow \uparrow	$e^2 t_2^3$
d^6	$\uparrow\downarrow$ \uparrow	\uparrow \uparrow \uparrow	$e^3 t_2^3$
d^7	$\uparrow\downarrow$ $\uparrow\downarrow$	\uparrow \uparrow \uparrow	$e^4 t_2^3$
d^8	$\uparrow\downarrow$ $\uparrow\downarrow$	$\uparrow\downarrow$ \uparrow \uparrow	$e^4 t_2^4$
d^9	$\uparrow\downarrow$ $\uparrow\downarrow$	$\uparrow\downarrow$ $\uparrow\downarrow$ \uparrow	$e^4 t_2^5$
d^{10}	$\uparrow\downarrow$ $\uparrow\downarrow$	$\uparrow\downarrow$ $\uparrow\downarrow$ $\uparrow\downarrow$	$e^4 t_2^6$

Crystal Field Splitting of d-orbitals in Tetragonal and Square Planar Complexes

If two trans ligands in an octahedral ML_6 complex (for example those along the z axis) are moved either towards or away from the metal ion, the resulting complex is said to be tetragonally distorted. Ordinarily such distortions are not favored since they result in a net of loss of bonding energy. In certain situation, however, such a distortion is favored because of Jahn-Teller effect.

A complex of general formula trans- MA_2B_4 also will have tetragonal symmetry. For now, we will merely consider the limiting case of tetragonal elongation, a square planar ML_4 complex, for the purpose of deriving its d orbital splitting pattern.

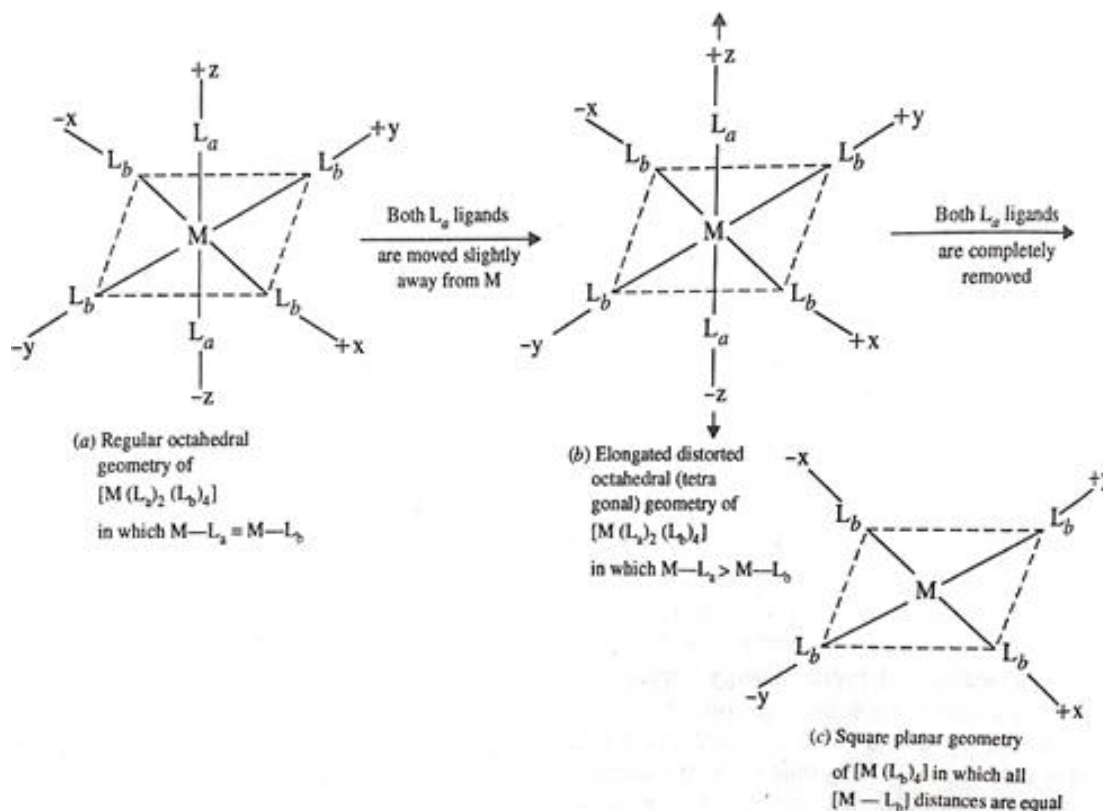

The figure below illustrates the effect of z-axis stretching on the e_g and t_{2g} orbitals in an octahedral complex. Orbitals having a z component (the d_z^2 , d_{xz} and d_{yz}) will experience a decrease in electrostatic repulsion from the ligands and will therefore be stabilized. At the same time, the “non-z” orbitals will be raised in energy, with the barycenter remaining constant. The overall result is that the e_g level is split into two levels, an upper ($d_x^2 - d_y^2$) and a lower (d_z^2) and the t_{2g} set is split into (d_{xy}) and a doubly degenerate (d_{xz} , d_{yz}).

The energy spacing between the (d_{xy}) and ($d_x^2 - d_y^2$) levels is defined as Δ . As in the octahedral case, this splitting is equal to $10Dq$.

The square planar geometry is favored by metal ions having a d^8 configuration in the presence of a strong field. This combination gives low spin complexes with the eight d electrons occupying the low-energy d_{xz} , d_{yz} , d_z^2 , and d_{xy} orbitals, while the high-energy $d_x^2 - d_y^2$ orbital remains unoccupied. The stronger the surrounding field, the higher the $d_x^2 - d_y^2$ orbital will be raised. As long as this level is unoccupied, however, the overall effect on the complex will be stabilization because the lower, occupied orbitals will drop in energy by corresponding amount.

Typical low spin square planar complexes are $[\text{Ni}(\text{CN})_4]^{2-}$, $[\text{PdCl}_4]^{2-}$, $[\text{Pt}(\text{NH}_3)_4]^{2+}$, $[\text{PtCl}_4]^{2-}$, and $[\text{AuCl}_4]^-$, all d^8 species.

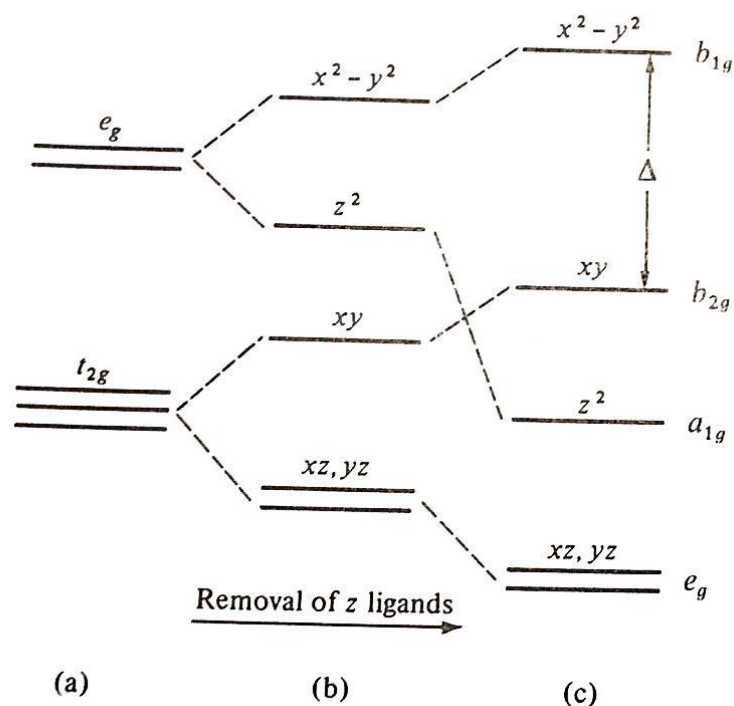

The Jahn-Teller Effect

The Jahn-Teller theorem states that there cannot be unequal occupation of orbitals with identical energies. To avoid such unequal occupation, the molecule distorts so that these orbitals are no longer degenerate. For example, octahedral $\text{Cu}(\text{II})$, a d^9 ion, would have three electrons in the two e_g levels without the Jahn-Teller effect, as in the center of the Figure below. The Jahn-Teller effect requires that the shape of the complex change slightly, resulting in a change in the energies of the orbitals. The resulting distortion is most often an elongation along one axis, but compression along one axis is also possible.

In octahedral complexes, where the e_g orbitals are directed towards the ligands, distortion of the complex has a larger effect on these energy levels and a smaller effect when the t_{2g} orbitals are involved.

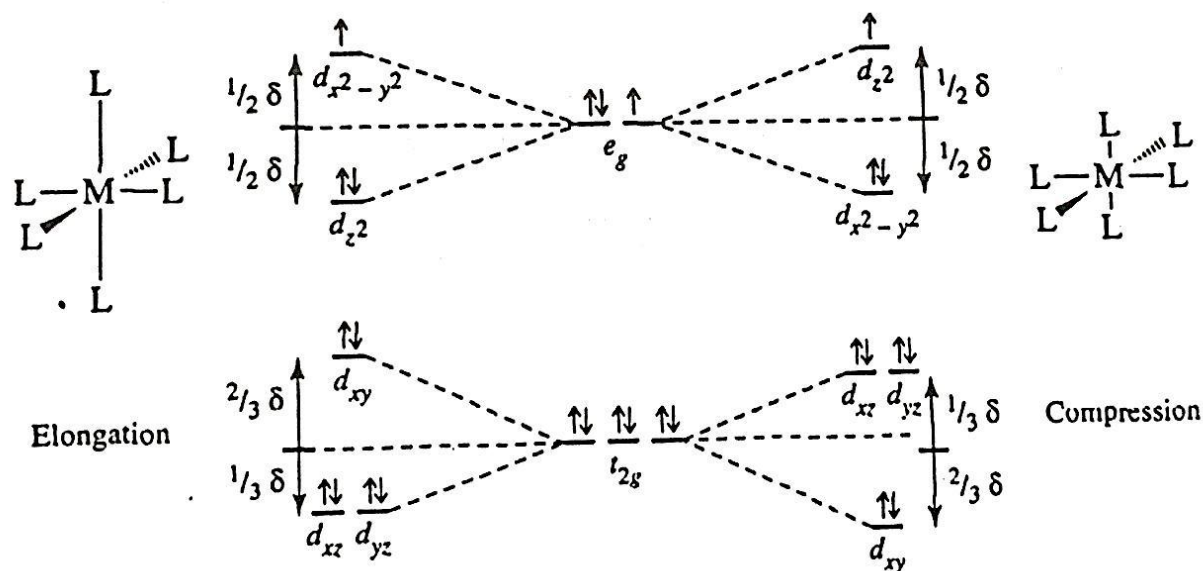

Examples of significant Jahn-Teller are found in complexes :

d^4 high spin (weak ligands) Cr(II) and Mn(III)

d^7 low spin (strong ligands) Co(II) and Ni(III)

d^9 (strong or weak ligands) Cu(II) and Ag(II)

Limitation of CFT

- 1- CFT considers only the metal ion d-orbitals and gives no consideration at all to other metal orbitals such as s, p_x , p_y , and p_z orbitals and the ligand π -orbitals. Therefore, to explain all the properties of the complexes dependent on the π -ligand orbitals will be outside the scope of CFT. CFT does not consider the formation of π -bonding in complexes.
- 2- CFT is unable to account satisfactorily for the relative strengths of ligand, e.g. , it gives no explanation as to why H_2O appears in the spectrochemical series as a stronger ligand than OH^- .
- 3- According to CFT, the bond between the metal and ligand is purely ionic, It gives no account of the partly covalent nature of the metal-ligand bonds.