

## Atmospheric Optics

Index of refraction, index of refraction for air, scattering, geometric optics regime, Rayleigh scattering regime, Mie scattering regime, mirages, primary rainbows, secondary rainbows, prisms, refraction of light through ice crystals, halos, sun dogs, and sun pillars.

# Chapter Five

## Atmospheric Optics

### 5-1 Blue Skies and Hazy Days الايام المغيرة و السماء الصافية

As sunlight enters the atmosphere, the shorter visible wavelengths of violet, blue, and green are scattered more by atmospheric gases than are the longer wavelengths of yellow, orange, and especially red. (Violet light is scattered about 16 times more than red light.) As we view the sky, the scattered waves of violet, blue, and green strike the eye from all directions. Because our eyes are more sensitive to blue light, these waves, viewed together, produce the sensation of blue coming from all around us (see Fig. 5.1).

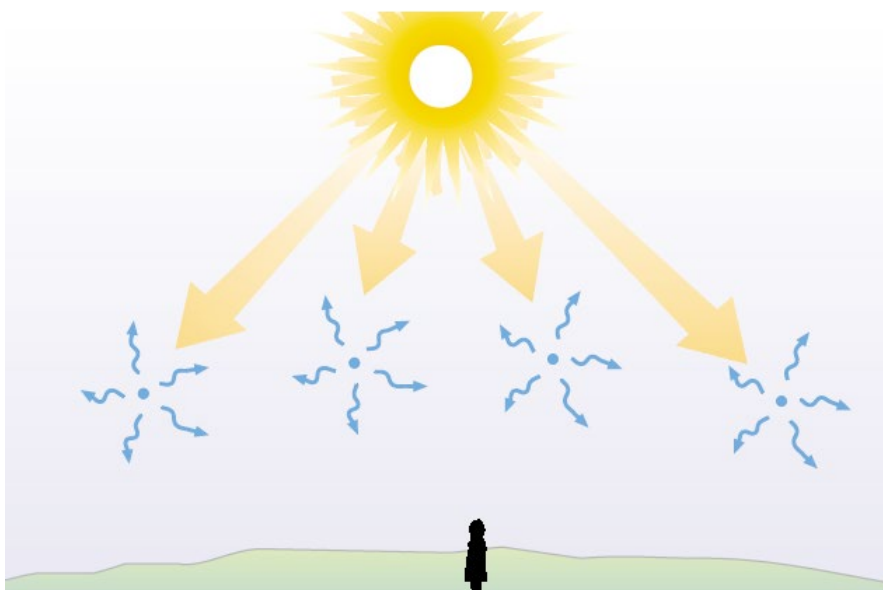

Figure 5.1: The sky appears blue because billions of air molecules selectively scatter the shorter wavelengths of visible light more effectively than the longer ones. This causes us to see blue light coming from all directions.

When small particles, such as fine dust and salt, become suspended in the atmosphere, the color of the sky begins to change from blue to milky white. Although these particles are small, they are large enough to scatter all wavelengths of visible light equally in all directions. When our eyes are

## Atmospheric Optics

Index of refraction, index of refraction for air, scattering, geometric optics regime, Rayleigh scattering regime, Mie scattering regime, mirages, primary rainbows, secondary rainbows, prisms, refraction of light through ice crystals, halos, sun dogs, and sun pillars.

attacked by all wavelengths of visible light, the sky appears **milky white**, the visibility lowers, and we call the day “**hazy**.”

## 5-2 Twinkling, Twilight, and the Green Flash التلألؤ والشفق والوميض الأخضر

Light that passes through a substance is said to be *transmitted*. Upon entering a denser substance, transmitted light slows in speed. If it enters the substance at an angle, the light's path also bends. This bending is called **refraction**. The amount of refraction depends primarily on two factors: **the density of the material and the angle at which the light enters the material**.

Figure 5.2.

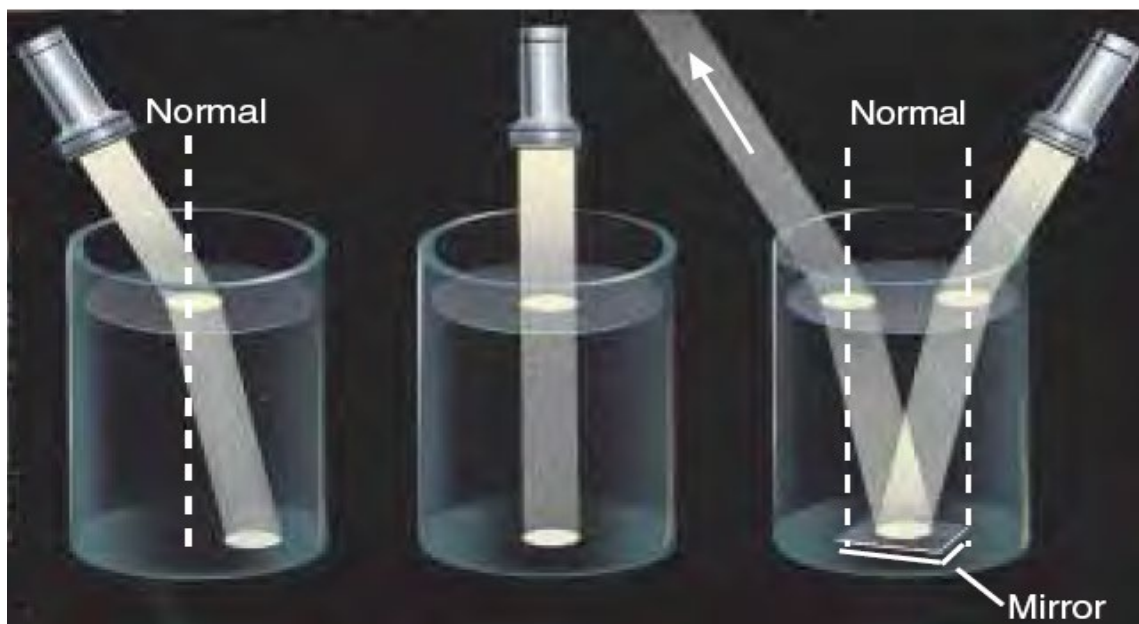

Figure 5.2: light behavior as it enters and leaves a more- dense substance such as water

As starlight enters the atmosphere, it often passes through regions of differing air density. Each of these regions deflects and bends the tiny beam of starlight, constantly changing the apparent position of the star. This causes the star to appear to **twinkle**, a condition known as **scintillation**. Planets, being much closer to us, appear larger, and usually do not twinkle because their size is greater than the angle at which their light deviates as it

## Atmospheric Optics

Index of refraction, index of refraction for air, scattering, geometric optics regime, Rayleigh scattering regime, Mie scattering regime, mirages, primary rainbows, secondary rainbows, prisms, refraction of light through ice crystals, halos, sun dogs, and sun pillars.

penetrates the atmosphere. Planets sometimes twinkle, however, when they are near the horizon, where the bending of their light is greatest.

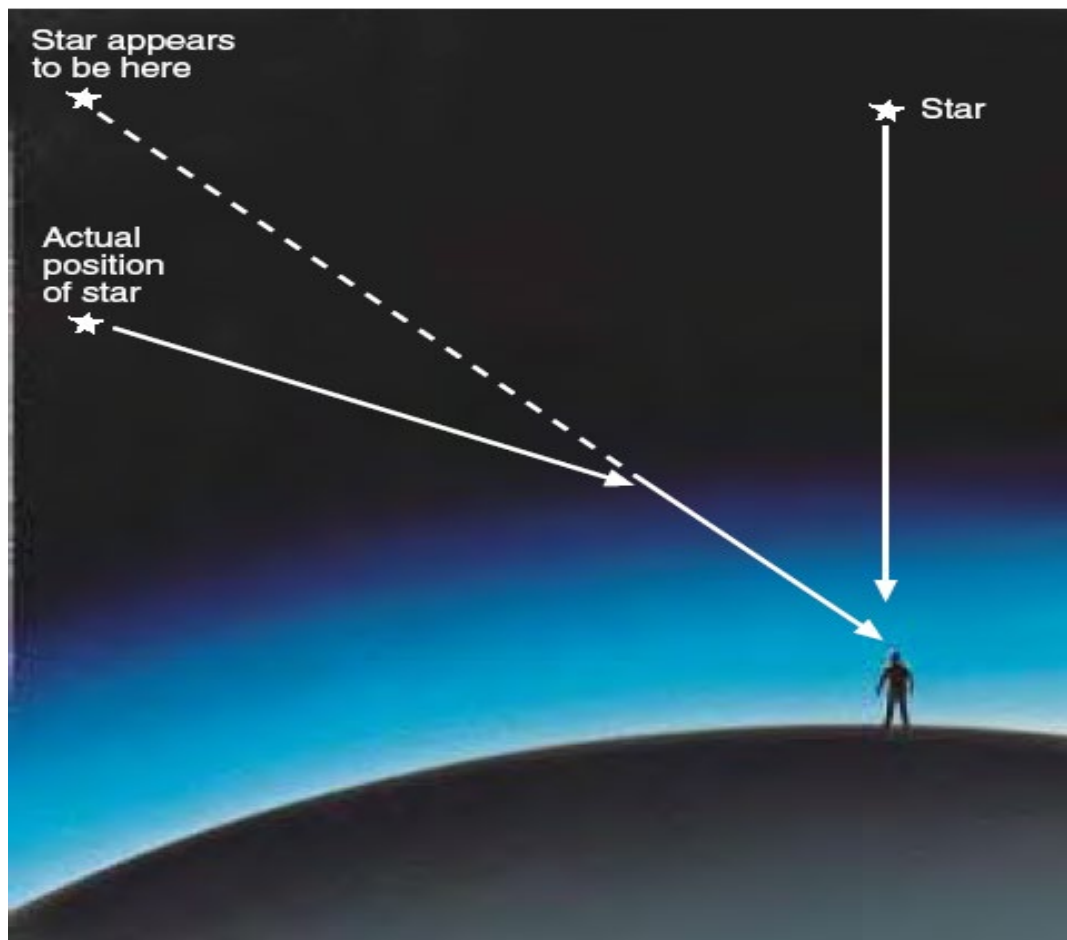

Figure 5.3: Due to the bending of starlight by the atmosphere stars not directly overhead appear to be higher than they really

In general, without the atmosphere, there would be **no refraction** or scattering, and the sun would rise later and set earlier than it now does. Instead of twilight, darkness would arrive immediately when the sun disappeared below the horizon.

Occasionally, a *flash of green light*—called the green flash—may be seen near the upper edge of a rising or setting sun (see Fig. 5.4). Usually, the green light is too faint to see with the human eye. However, under certain atmospheric conditions, such as when the **surface air is very hot** or when an **upper-level inversion exists**, the green light is magnified by the atmosphere.

## Atmospheric Optics

Index of refraction, index of refraction for air, scattering, geometric optics regime, Rayleigh scattering regime, Mie scattering regime, mirages, primary rainbows, secondary rainbows, prisms, refraction of light through ice crystals, halos, sun dogs, and sun pillars.



**Figure 5.4:** Green flash appear as green light on the upper edge of the sun, we can observe how the atmosphere makes the sun appear to flatten on the horizon in to an elliptical shape

### 5-3 The Mirage:

In the atmosphere, when an object appears to be displaced from its true position, we call this phenomenon a **Mirage**. Atmospheric mirages are created by light passing being bent by air layers of different densities. Such changes in air density are usually caused by sharp changes in air temperature. The greater the rate of temperature change, the greater the light rays are bent.

Air over street, consider as hot surfaces warms by conduction and, because air is a poor thermal conductor, we find much cooler air only a few meters higher. On hot days, these road surfaces often appear wet (see Fig. 5.5).

### Atmospheric Optics

Index of refraction, index of refraction for air, scattering, geometric optics regime, Rayleigh scattering regime, Mie scattering regime, mirages, primary rainbows, secondary rainbows, prisms, refraction of light through ice crystals, halos, sun dogs, and sun pillars.



**Figure 5.5:** The road in the photo appears wet because blue skylight is bending up into the camera as the light passes through air of different densities.

### 5-3 Halos: الهالات

The most common type of halo is the  $22^\circ$  halo—a ring of light  $22^\circ$  from the sun or moon. Such a halo forms when tiny suspended column-type ice crystals (with diameters less than 20 micrometers) become randomly oriented as air molecules constantly bump against them. *The refraction* of light rays through these crystals forms a halo like the one shown in Fig. 5.6.

### 5-4 Rainbows قوس قزح

Rainbows occur when rain is falling in one part of the sky, and the sun is shining in another. However, when we see a rainbow in the morning, we are facing west, toward the rain shower. As sunlight enters a raindrop, it slows and bends, with violet light refracting the most and red light the least (see Fig. 5.7). Although most of this light passes through the drop and is not seen by us, some of it strikes the backside of the drop at such an angle that it is reflected within the drop. The angle at which this occurs is called the **critical angle**. Light that strikes the back of a raindrop at an angle exceeding the critical angle bounces off the back of the Drop and is *internally reflected* toward our eyes (see Fig. 5.7a). Because each light ray bends differently from the rest, each ray emerges from the drop at a slightly different angle. For red light, the angle is  $42^\circ$  from the beam of sunlight; for violet light, it is  $40^\circ$  (see Fig. 5.7b).

## Atmospheric Optics

Index of refraction, index of refraction for air, scattering, geometric optics regime, Rayleigh scattering regime, Mie scattering regime, mirages, primary rainbows, secondary rainbows, prisms, refraction of light through ice crystals, halos, sun dogs, and sun pillars.

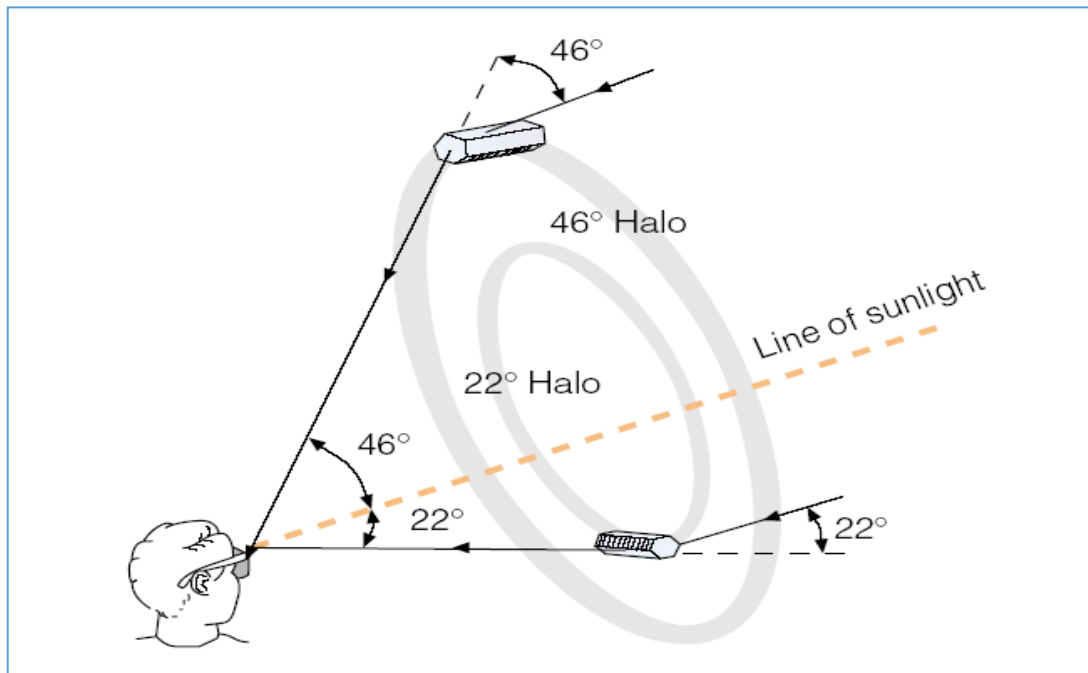

Figure 5.6: formation of 22° and 46° halo with column-type ice crystals

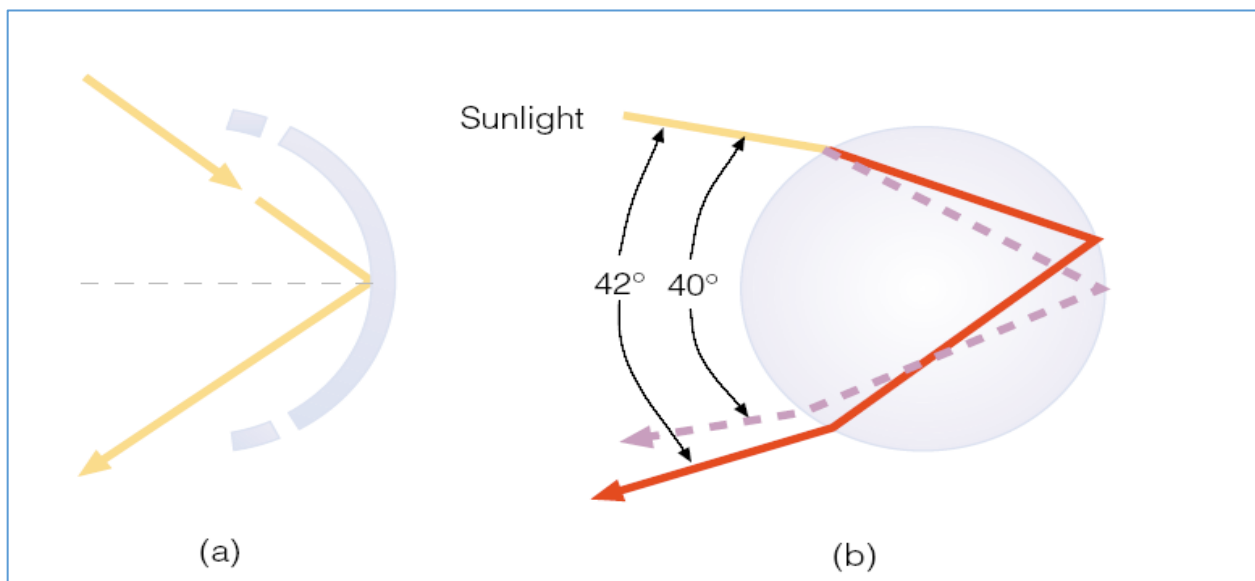

Figure 5.7: sunlight internally reflected and dispersed by a raindrop. (a) The light ray is internally reflected only when it strikes the backside of the drop at an angle greater than the critical angle for water. (b) Refraction of the light as it enters the drop causes the point of reflection (on the back of the drop) to be different for each color. Hence the colors are separated from each other when the light emerges from the raindrop