

CHAPTER 1

Introduction to Computer Graphics

1.1 What is computer graphics?

it would be difficult to overstate the importance of computer and communication technologies in our lives. Activities as wide-ranging as film making, publishing, banking, and education have undergone revolutionary changes as these technologies alter the ways in which we conduct our daily activities. The combination of computers, networks, and the complex human visual system, through computer graphics, has been instrumental in these advances and has led to new ways of displaying information, seeing virtual worlds, and communicating with both other people and machines.

Computer graphics is concerned with all aspects of producing pictures or images using a computer.

“**Computer graphics**” also refers to the **tools** used to make such pictures.

There are both **hardware** and **software** tools. *Hardware* tools include video monitors and printers that display graphics, as well as input devices like a mouse or trackball that let a user point to items and draw figures. The computer itself, of course, is a hardware tool, along with its special circuitry to facilitate graphical display or image capture.

As for *software* tools, you are already familiar with the usual ones: the operating system, editor, compiler, and debugger, that are found in any programming environment. For graphics there must also be a collection of “graphics routines” that produce the pictures themselves.

Computer graphics is a very appealing field of study. You learn to write programs that create pictures, rather than streams of text or numbers. Humans respond readily to pictorial information, and are

able to absorb much more information from pictures than from a collection of numbers.

People study computer graphics for many reasons. Some just want a better set of tools for plotting curves and presenting the data they encounter in their other studies or work. Some want to write computer animated games, while others are looking for a new medium for artistic expression. Everyone wants to be more productive, and to communicate ideas better, and computer graphics can be a great help.

1.2 Application of Computer Graphics

- 1. Paint programs:** Allow you to create rough freehand drawings. The images are stored as bit maps and can easily be edited. It is a graphics program that enables you to draw pictures on the display screen which is represented as bit maps (bit-mapped graphics).
- 2. Illustration/design programs:** Illustration/design programs are often called draw programs. Presentation graphics software: Lets you create bar charts, pie charts, graphics, and other types of images for slide shows and reports. The charts can be based on data imported from spreadsheet applications.
- 3. Animation software:** Enables you to chain and sequence a series of images to simulate movement. Each image is like a frame in a movie. It can be defined as a simulation of movement created by displaying a series of pictures, or frames. A cartoon on television is one example of animation.
- 4. CAD software:** Enables architects and engineers to draft designs. It is the acronym for computer-aided design. A CAD system is a combination of hardware and software that enables engineers and architects to design everything from furniture to airplanes. In addition to the software, CAD systems require a

high-quality graphics monitor; a mouse, light pen, or digitizing tablet for drawing; and a special printer or plotter for printing design specifications.

5. **Desktop publishing:** Provides a full set of word-processing features as well as fine control over placement of text and graphics, so that you can create newsletters, advertisements, books, and other types of documents. It means by using a personal computer or workstation high-quality printed documents can be produced. A desktop publishing system allows you to use different typefaces, specify various margins and justifications, and embed illustrations and graphs directly into the text. The most powerful desktop publishing systems enable you to create illustrations; while less powerful systems let you insert illustrations created by other programs.

6. **Virtual –Reality Environments:** a more recent application of computer graphics is in the creation of Virtual –Reality Environments in which a user can interact with the objects in a three-dimensional scene.

7. **Entertainment:** Television production, motion picture ,and music videos routinely use computer graphics method.

1.3 Elements of Pictures Created in Computer Graphics

What makes up a computer drawn picture? The basic objects out of which such pictures are composed are called output primitives. One useful categorization of these is:

- polylines
- text
- filled regions
- raster images

1. Polylines

A **polyline** is a connected sequence of straight lines.

When there are several lines in a polyline each one is called an **edge**, and two adjacent lines meet at a **vertex**.



Edge vertex

Figure 1.1 Example of Edge and Vertex.

A **polyline** need not form a closed figure, but if the first and last points are connected by an edge the polyline is a **polygon**.

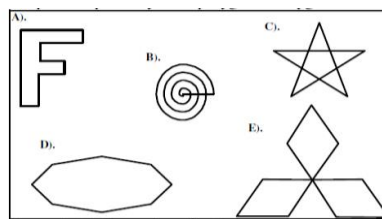

Figure 1.2 Examples of polygons.

For instance, the polyline shown in Figure 1 is given by the sequence $(2, 4), (2, 11), (6, 14), (12, 11), (12, 4), \dots$ (what are the remaining vertices in this polyline?).

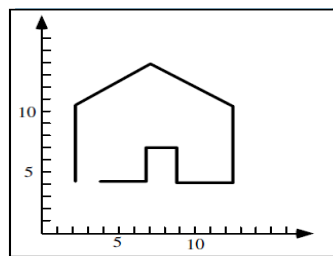

Figure 1.3 An example polyline.

Attributes of Lines and Polylines

The attributes of a graphic primitive are the characteristics that affect how it appears, and some Important attributes of a polyline are the color and thickness of its edges, the manner in which the edges are dashed, and the manner in which thick edges blend together at their endpoints. Typically all of the edges of a polyline are given the same attributes.

2. Text

Some graphics devices have two distinct display modes, a text mode and a graphics mode. The text mode is used for simple input/output of characters to control the operating system or edit the code in a program.

Text displayed in this mode uses a built-in character generator. The character generator is capable of drawing alphabetic, numeric, and punctuation characters, and some selection of special symbols such as ♥, ð, and ⊕ .

Compare with the *graphic mode*, the PC's **text mode** is easy to use. Displaying information on the screen is as simple as placing ASCII char in specific memory location. The text screen is divided into 80 column and 25 rows. The **graphic mode** requires a completely different orientation instead of character; you have **pixels**, the smallest picture element on your computer display. Today most screens can display text and graphics.

Attributes of Text

There are many text attributes, the most important of which are typeface, color, size, spacing, and Orientation.

A font is a specific set of character shapes (a typeface) in a particular style and size.

3. Filled Regions

The filled region (sometimes called “fill area”) primitive is a shape filled with some color or pattern. The boundary of a filled region is often a polygon

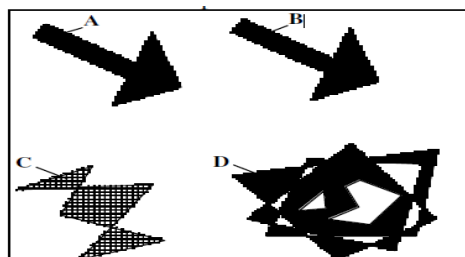

Figure 1.4 Examples of filled Polygons.

4. Raster Image.

A **raster image** It is made up of many small “cells”, in different shades of gray, The individual cells are often called “pixels” (short for “picture elements”). Normally your eye can’t see the individual cells; it blends them together and synthesizes an overall picture.

A raster image is stored in a computer as an array of numerical values. This array is thought of as being rectangular, with a certain number of rows and a certain number of columns. Each numerical value represents the value of the pixel stored there. The array as a whole is often called a “**pixel map**”. The term “**bitmap**” is also used. A simple figure represented as a bitmap.

Figure 1.5 shows a simple example where a figure is represented by a 17 by 19 array (17 rows by 19 columns) of cells in three shades of gray. Suppose the three gray levels are encoded as the values 1, 2, and 7.

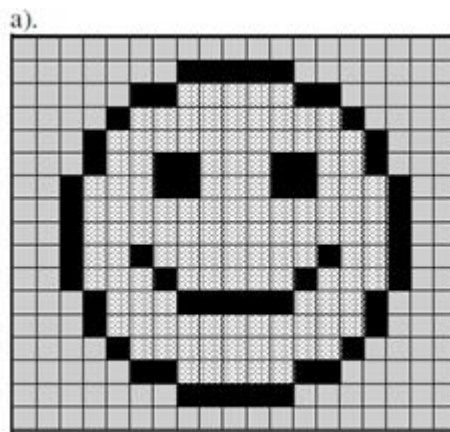

Figure 1.5 A simple figure represented as a bitmap.

How are raster images created?

The three principal sources are:

1. Hand designed images.

A designer figures out what values are needed for each cell, and types them into memory. Sometimes a paint program can be used to help automate this: the designer can draw and manipulate various graphical shapes, viewing what has been made so far. When satisfied, the designer stores the result in a file.

2. Computed Images.

An algorithm is used to “render” a scene, which might be modeled abstractly in computer memory. As a simple example, a scene might consist of a single yellow smooth sphere illuminated by a light source that emanates orange light.

3. Scanned images.

A photograph or television image can be digitized as described above. In effect a grid is placed over the original image, and at each grid point the digitizer reads into memory the “closest” color in its repertoire. The bitmap is then stored in a file for later use.

1.4 Raster Graphics

An image that is presented on the computer screen is made up of **pixels**. The screen consists of a rectangular grid of pixels, arranged in rows and columns. The pixels are small enough that they are not easy to see individually. In fact, for many very high-resolution displays, they become essentially invisible. At a given time, each pixel can show only one color. Most screens these days use 24-bit color, where a color can be specified by three 8-bit numbers, giving the levels of red, green, and blue in the color. Any color that can be shown on the screen is made up of some combination of these three “primary” colors. As we can see from Figure 1.6

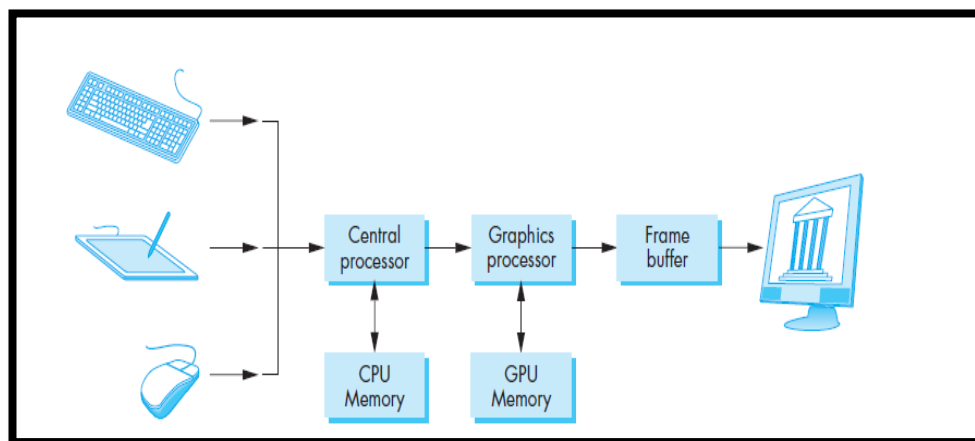

Figure 1. 6 graphical system

In any case, the color values for all the pixels on the screen are stored in a large block of memory known as a **frame buffer**. Changing the image on the screen requires changing color values that are stored in the frame buffer. The screen is redrawn many times per second, so that almost immediately after the color values are changed in the frame buffer, the colors of the pixels on the screen will be changed to match, and the displayed image will change.

A computer screen used in this way is the basic model of **raster graphics**. The term “raster” technically refers to the mechanism used on older vacuum tube computer monitors: An electron beam would move along the rows of pixels, making them glow. The beam was moved across the screen by powerful magnets that would deflect the path of the electrons. The stronger the beam, the brighter the glow of

the pixel, so the brightness of the pixels could be controlled by modulating the intensity of the electron beam. The color values stored in the frame buffer were used to determine the intensity of the electron beam. (For a color screen, each pixel had a red dot, a green dot, and a blue dot, which were separately illuminated by the beam.)

A modern flat-screen computer monitor is not a raster in the same sense. There is no moving electron beam. The mechanism that controls the colors of the pixels is different for different types of screen. But the screen is still made up of pixels, and the color values for all the pixels are still stored in a frame buffer. The idea of an image consisting of a grid of pixels, with numerical color values for each pixel, defines **raster graphics**.

1.5 Display Screens

Display screens are output devices that show programming instructions and data as they are being and information after it is processed, display screens are either CRT (Cathode-Ray-Tube) or flat-panel display.

1. CRT Displays: use vacuum tube like that in a TV set.
2. Flat-panel displays: are thinner, weightless, and consume less power than CRT displays but are not as clear. Principal flat-panel displays are liquid-crystal displays (LCD) and gas-plasma display.

The size of screen is measured diagonally from corner to corner in inches.

1. The Cathode Ray Tube (CRT) Display:

The CRT display screens consist of three components:

- a. Cathode Ray Tube (CRT).
- b. Frame buffer.
- c. Display controller.

a. Cathode Ray Tube (CRT):

Consists of electron gun that contains a cathode that when heated emits a beam of negatively charged electrons towards a positively charged phosphor coated screen. The electron beam passes through the focusing and deflection system, which consist of an electrostatic or magnetic field. A color CRT has three electron guns, one for each of three primary colors: red, green, and blue.

The focusing system concentrates the beam so that by the time the electrons reach the screen, they have converted to small dot. The deflection system, which consists of two pairs of deflection plates (horizontal and vertical) directs the electron beam to any point on the screen.

When the electron beam strikes the screen, the phosphor emits a spot of visible light that intensity depends on the number of electrons on the beam. The duration of this light, called persistence, depends on the type of phosphor that coats the screen. In order to give the viewer the appearance of continuous flicker-free image, each dot on the screen must be intensified many times per second. This type of CRT is called a refresh CRT. Two types of refresh CRTs are available: raster-scan and random vector.

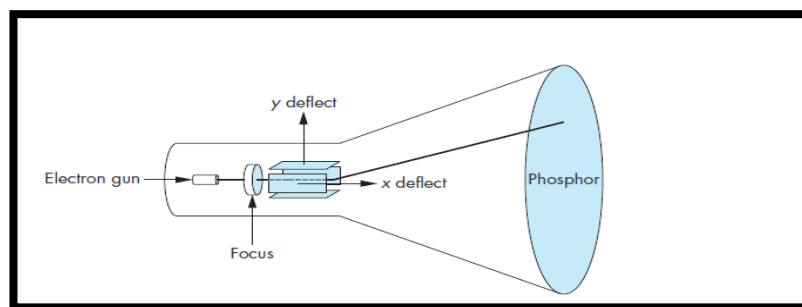

Figure 1.7 The Cathode -Ray Tube(CRT)

b. Frame Buffer:

Each screen pixel corresponds to a particular entry in a two dimensional array residing in memory. This memory is called a frame buffer or a bit map. The number of rows in the frame buffer array equals the number of raster lines on the display screen. The number

of columns in this array equals the number of pixels on each raster line.

The term pixel (picture element) is also used to describe the row and column location in the frame buffer arrays that corresponds to the screen location. A 512×512 display screen requires 262,144 pixel memory location. Whenever we wish to display a pixel on the screen, a specific value is placed into the corresponding memory location in the frame buffer array. Each screen location pixel and corresponding memory location in the frame buffer is accessed by an (X,Y) integer coordinate pair. The x value refers to the columns, the y value to the row position.

Each pixel in the frame buffer array is composed of a number of bits. A black and white image that has only two intensity levels, on-off, has single bit plane frame buffer. In order to display a color or a black and white quality image with shades of gray, additional bit planes are needed.

c. Display Controller:

The hardware device that read the contents of the frame buffer into video buffer, which then converts the digital representation of a string of pixel values into analogue voltage signals that are sent serially to the video display screen (CRT).

2. The Flat Panel Display:

Compared to CRT displays, flat panel displays are much thinner, weightless, and consuming less power. Thus they are better for portable computers. Flat panel displays are made up of two plates of glass with a substance between them, which is activating in different ways. Flat panel displays are distinguished in two ways:

- 1- By the substance between the plates of glass.
- 2- By the arrangement of the transistors in the screens.

Two common types of technology used in flat panel display screens are:

a. Liquid Crystal display (LCD):

It consists of a substance called liquid crystal, the molecules of which line up in a way that alter their optical properties. As a result, light usually backlighting behind the screen is blocked or allowed through to create an image.

b. Gas Plasma Display:

It is like a neon bulb, in which the display uses a gas that emits light in the presence of an electric current. That is, the technology uses neon gas and electrodes above and below the gas. When electric current passes between the electrodes, the gas glows. Although gas plasma technology has better resolution than LCD technology, it is more expensive and thus is not used as often as a LCD. On the other hand, LCDs are not practical for screens larger than 20 inches and so are not practical for TV size screen.

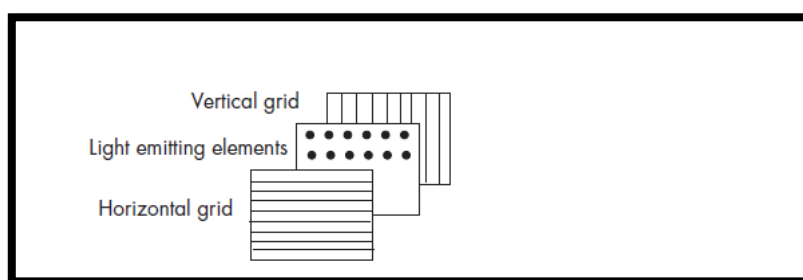

Figure 1.8 Generic flat panel display

1.6 Screen Clarity:

The screen clarity depends on three qualities:

1. Resolution:

Resolution is the numbers of pixels in digital image with $N \times M$ (N horizontal pixels \times M vertical pixels), the number of pixels give the capacity to display the details in original image. Resolution is expressed in terms of the formula Each pixel can be assigned a color or particular shade of gray. A screen with 640×480 pixels multiplied together equals 307200 pixels. This screen will be less clear and sharp than a screen with 800×600 (equals 480000) Or 1024×768 (equals 786432) pixels.

Resolution depend on :

1. Special resolution (number of pixels).
2. Brightness resolution (values of pixels).

2. Dot Pitch:

It is the amount of space between the center of adjacent pixels, the closer the dots, the crisper the image. For crisp images, dot pitch should be less than 0.31 millimeter.

3. Refresh Rate:

It is the number of times per second that the pixels are recharged so that their glow remains bright. In general, displays are refreshed 45 to 100 times per second.