

## Chapter Three Motion in two dimensions

### 3.1 The Position, Velocity, and Acceleration Vectors

In chapter 2 we found that the motion of a particle moving along a straight line is completely known if its position is known as a function of time. Now let us extend this idea to motion in the xy-plane. We begin by describing the position of a particle by its **position vector**  $\vec{r}$ , drawn from the origin of some coordinate system to the particle located in the xy-plane, as in figure 3.1. The **displacement vector**  $\Delta\vec{r}$  for the particle is defined as the difference between its final position vector and its initial position vector

$$\Delta\vec{r} = \vec{r}_f - \vec{r}_i \quad \dots\dots\dots(3-1-1)$$

The **average velocity**  $\vec{v}_{ave}$  of a particle during the time interval  $\Delta t$  is defined as the displacement of the particle divided by the time interval.

$$\vec{v}_{ave} = \frac{\Delta\vec{r}}{\Delta t} \quad \dots\dots\dots(3-1-2)$$

Note that the average velocity between points is independent of the path taken. This is because average velocity is proportional to displacement, which depends only on the initial and final position vectors and not on the path taken.

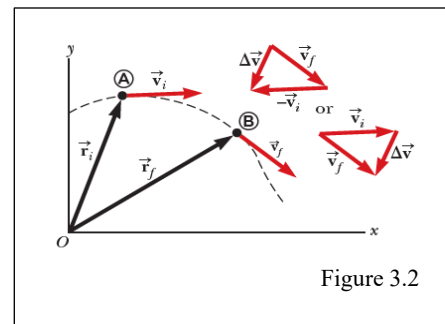
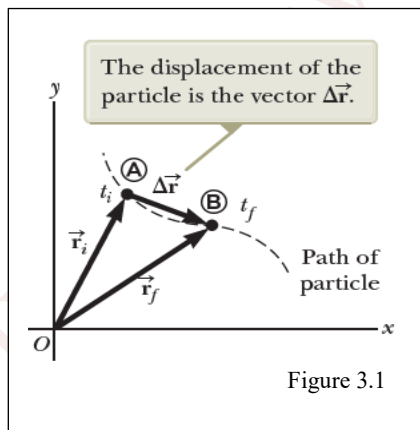

The **instantaneous velocity**  $\vec{v}$  is defined as the limit of the average velocity  $\Delta\vec{r}/\Delta t$  as  $\Delta t$  approaches zero

$$\vec{v} = \lim_{\Delta t \rightarrow 0} \frac{\Delta\vec{r}}{\Delta t} = \frac{d\vec{r}}{dt} \quad \dots\dots\dots(3-1-3)$$

That is, the instantaneous velocity equals the derivative of the position vector with respect to time.

The direction of the instantaneous velocity vector at any point in a particle's path is along a line tangent to the path at that point and in the direction of motion as shown

in figure 3.2. The magnitude of the instantaneous velocity vector  $v = |\vec{v}|$  is called the speed, which is a scalar quantity. The **average acceleration** of a particle as it moves is defined as the change in the instantaneous velocity vector  $\Delta\vec{v}$  divided by the time interval  $\Delta t$  during which that change occurs

$$\vec{a}_{ave} = \frac{\Delta\vec{v}}{\Delta t} = \frac{\vec{v}_f - \vec{v}_i}{t_f - t_i} \dots\dots\dots(3-1-4)$$

The **instantaneous acceleration**  $a$  is defined as the limiting value of the ratio  $\Delta\vec{v}/\Delta t$  as  $\Delta t$  approaches zero

$$\vec{a} = \lim_{\Delta t \rightarrow 0} \frac{\Delta\vec{v}}{\Delta t} = \frac{d\vec{v}}{dt} \dots\dots\dots(3-1-5)$$

### 3.2 Two-Dimensional Motion with Constant Acceleration

The position vector for a particle moving in the xy-plane can be written

$$\vec{r} = x\hat{i} + y\hat{j} \dots\dots\dots(3-2-1)$$

If the position vector is known, the velocity of the particle can be obtained

$$\vec{v} = \frac{d\vec{r}}{dt} = v_x\hat{i} + v_y\hat{j} \dots\dots\dots(3-2-2)$$

Substituting,  $v_{xf} = v_{xi} + a_x t$  and  $v_{yf} = v_{yi} + a_y t$  into the equation (3-2-2), we will obtain

$$\begin{aligned} \vec{v}_f &= (v_{xi} + a_x t)\hat{i} + (v_{yi} + a_y t)\hat{j} \rightarrow \vec{v}_f = (v_{xi}\hat{i} + v_{yi}\hat{j}) + (a_x t\hat{i} + a_y t\hat{j}) \\ \vec{v}_f &= \vec{v}_i + \vec{a}t \dots\dots\dots(3-2-3) \end{aligned}$$

Similarly, substituting both  $x_f - x_i = v_{xi}t + \frac{1}{2}a_x t^2$  and  $y_f - y_i = v_{yi}t + \frac{1}{2}a_y t^2$  into equation (3-2-1)

$$\begin{aligned} (x_f\hat{i} + y_f\hat{j}) &= (x_i\hat{i} + y_i\hat{j}) + (v_{xi}\hat{i} + v_{yi}\hat{j})t + \frac{1}{2}(a_x\hat{i} + a_y\hat{j})t^2 \\ \vec{r}_f &= \vec{r}_i + \vec{v}_i t + \frac{1}{2}\vec{a}t^2 \dots\dots\dots(3-2-4) \end{aligned}$$

**Ex:** A particle moves in the xy-plane, starting from the origin at  $t=0$  with an initial velocity having an x-component of 20 m/s and a y-component of -15 m/s. The particle experiences an acceleration in the x-direction, given by 4.0 m/s<sup>2</sup>. (A) Determine the total velocity vector at any time. (B) Calculate the velocity and speed of the particle at  $t=5.0$  s and the angle the velocity vector makes with the x axis. (C) Determine the x and y coordinates of the particle at any time  $t$  and its position vector at this time.

**Solution**

We have:  $v_{xi}=20$  m/s,  $v_{yi}=-15$  m/s,  $a_x=4.0$  m/s<sup>2</sup> and  $a_y=0$  m/s<sup>2</sup>

(A)

$$\vec{v}_f = \vec{v}_i + \vec{a}t = (v_{xi}\hat{i} + v_{yi}\hat{j}) + (a_x t\hat{i} + a_y t\hat{j})$$

$$\vec{v}_f = (20\hat{i} - 15\hat{j}) + (4t\hat{i} + (0)t\hat{j}) \rightarrow \vec{v}_f = [(20 + 4t)\hat{i} - 15\hat{j}] \text{ m/s}$$

(B)

$$\vec{v}_f = [(20 + 4(5))\hat{i} - 15\hat{j}] \text{ m/s} = [40\hat{i} - 15\hat{j}] \text{ m/s}$$

$$\text{speed} \equiv |\vec{v}_f| = v_f = \sqrt{v_{xf}^2 + v_{yf}^2} = \sqrt{(40)^2 + (15)^2} = 43 \text{ m/s}$$

$$\theta = \tan^{-1}\left(\frac{v_{yf}}{v_{xf}}\right) = \tan^{-1}\left(\frac{-15}{40}\right) = -21^\circ$$

(C)

$$x_f - x_i = v_{xi}t + \frac{1}{2}a_x t^2 \rightarrow x_f = (20t + 2t^2) \text{ m}$$

$$y_f - y_i = v_{yi}t + \frac{1}{2}a_y t^2 \rightarrow y_f = (-15t) \text{ m}$$

$$\vec{r} = x\hat{i} + y\hat{j} \rightarrow \vec{r} = [(20t + 2t^2)\hat{i} - 15t\hat{j}] \text{ m}$$

**Ex:** A motorist drives south at 20 m/s for 3 min, then turns west and travels at 25 m/s for 2 min, and finally travels northwest at 30 m/s for 1 min. For this 6 min trip, find (a) the total vector displacement, (b) the average speed, and (c) the average velocity.

**Solution**

a)

$$\Delta\vec{r} = \vec{v}_1 t_1 + \vec{v}_2 t_2 + \vec{v}_3 t_3$$

$$\begin{aligned} \Delta\vec{r} = & (20 \text{ m/s})(180 \text{ s})(-\hat{j}) + (25 \text{ m/s})(120 \text{ s})(-\hat{i}) + \\ & [(30 \text{ m/s})(60 \text{ s}) \cos(45^\circ)(-\hat{i}) \\ & + (30 \text{ m/s})(60 \text{ s}) \sin(45^\circ)(\hat{j})] \end{aligned}$$

$$\Delta\vec{r} = -(3600 \text{ m})\hat{j} - (3000 \text{ m})\hat{i} + [-(1273 \text{ m})\hat{i} + (1273 \text{ m})\hat{j}]$$

$$\Delta\vec{r} = [-(4273)\hat{i} - (2327)\hat{j}] \text{ m} = [-(4.27)\hat{i} - (2.33)\hat{j}] \text{ km}$$

Also, the answer above can be written as:

$$|\Delta\vec{r}| = \Delta r = \sqrt{(-4.27)^2 + (-2.33)^2} = 4.87\text{km} \quad \text{at} \quad \theta = \tan^{-1}\left(\frac{2.33}{4.27}\right) = 28.6^\circ \text{ south of west or } \theta = 209^\circ \text{ from the east.}$$

b)

The total distance or the path-length traveled is:

$$d = (20 \text{ m/s})(180 \text{ s}) + (25 \text{ m/s})(120 \text{ s}) + (30 \text{ m/s})(60 \text{ s}) = 8400\text{m} = 8.4 \text{ km}$$

$$\text{average speed} = \frac{d}{t} = \frac{8.4\text{km}}{6 \text{ min}} = 23.3 \text{ m/s}$$

c)

$$\vec{v}_{\text{ave}} = \frac{\Delta\vec{r}}{t} = \frac{[-(4.27)\hat{i} - (2.33)\hat{j}]\text{km}}{6 \text{ min}} = [-(11.9)\hat{i} - (6.47)\hat{j}] \text{ m/s}$$

### 3.3 Projectile Motion

The Projectile moves in a curved path, and its motion is simple to analyze if we make two assumptions: (1) the free-fall acceleration  $g$  is constant over the range of motion and is directed downward, and (2) the effect of air resistance is negligible. With these assumptions, we find that the path of a projectile, which we call its trajectory, is always a parabola.

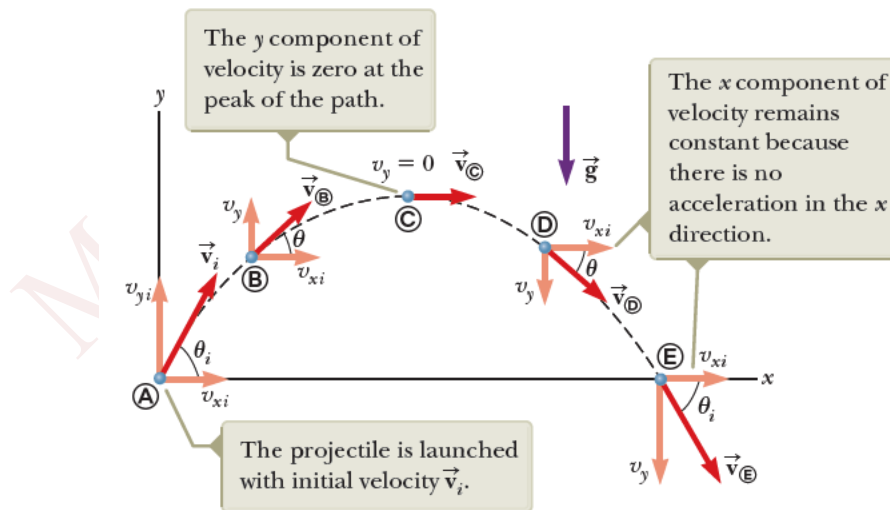

Figure 3.3

When solving projectile motion problems, use three analysis models:

1) The expression for the position vector of the projectile as a function of time is

$$\vec{r}_f = \vec{r}_i + \vec{v}_i t + \frac{1}{2} \vec{a} t^2$$

where the initial x and y components of the velocity of the projectile are

$$v_{xi} = v_i \cos \theta_i \quad \text{and} \quad v_{yi} = v_i \sin \theta_i$$

2) The particle under constant velocity in the horizontal direction

$$x_f - x_i = v_{xi}t + \frac{1}{2}a_x t^2 \quad \rightarrow \quad x_f = x_i + v_i \cos \theta_i t$$

3) The particle under constant acceleration in the vertical direction with  $a_y = -g$ :

$$v_{yf} = v_{yi} - gt \quad \rightarrow \quad v_{yf} = v_i \sin \theta_i - gt$$

$$y_f - y_i = v_{yi}t - \frac{1}{2}gt^2 \quad \rightarrow \quad y_f - y_i = v_i \sin \theta_i t - \frac{1}{2}gt^2$$

$$v_{yf}^2 = v_{yi}^2 - 2g(y_f - y_i) \quad \rightarrow \quad v_{yf}^2 = v_i^2 \sin^2 \theta_i - 2g(y_f - y_i)$$

**Ex:** Show that the trajectory of a projectile is a parabola.

Solution

Assume a projectile is launched from the origin  $x_i = y_i = 0$

$$x_f = x_i + v_i \cos \theta_i t \quad \rightarrow \quad x_f = v_i \cos \theta_i t \quad \dots\dots\dots(1)$$

$$y_f - y_i = v_{yi}t - \frac{1}{2}gt^2 \quad \rightarrow \quad y_f = v_i \sin \theta_i t - \frac{1}{2}gt^2 \quad \dots\dots\dots(2)$$

Insert equation (1) into equation (2)

$$y = v_i \sin \theta_i \frac{x}{v_i \cos \theta_i} - \frac{1}{2}g \left( \frac{x}{v_i \cos \theta_i} \right)^2$$

$$y = (\tan \theta_i)x - \left( \frac{g}{2v_i^2 \cos^2 \theta_i} \right)x^2$$

The equation is of the form  $y = ax - bx^2$ , which is the equation of a parabola that passes through the origin.

**3.3.1 Horizontal range and maximum height of a projectile:**

Assume a projectile is launched from the origin at  $t_i=0$ , with a positive  $v_{yi}$  component as shown in figure 3.4 and returns to the same horizontal level. Two points in this motion are especially interesting to analyze: the peak point **(A)**, which has Cartesian coordinates  $(R/2, h)$ , and the point **(B)**, which has coordinates  $(R, 0)$ . The distance R is called the horizontal range of the projectile, and the distance h is its maximum height. Let us find h and R mathematically in terms of  $v_i$ ,  $\theta_i$ , and g.

$$v_{yf} = v_{yi} - gt \rightarrow 0 = v_i \sin \theta_i - gt \textcircled{A}$$

$$t_{\textcircled{A}} = \frac{v_i \sin \theta_i}{g}$$

$$y_f = y_i + v_{yi}t - \frac{1}{2}gt^2 \rightarrow h = (v_i \sin \theta_i) \frac{v_i \sin \theta_i}{g} - \frac{1}{2}g \left( \frac{v_i \sin \theta_i}{g} \right)^2$$

$$h = \frac{v_i^2 \sin^2 \theta_i}{2g}$$

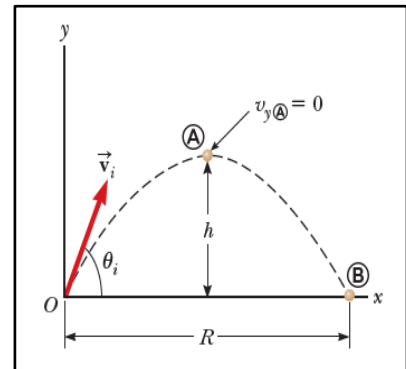

Figure 3.4

The range  $R$  is the horizontal position of the projectile at a time that is twice the time at which it reaches its peak, that is, at time  $t_B = 2t_A$ .

$$x_f = x_i + v_{xi}t \rightarrow R = v_{xi}t_{\textcircled{B}} = (v_i \cos \theta_i)2t_{\textcircled{A}}$$

$$= (v_i \cos \theta_i) \frac{2v_i \sin \theta_i}{g} = \frac{2v_i^2 \sin \theta_i \cos \theta_i}{g}$$

Using  $\sin 2\theta = 2 \sin \theta \cos \theta$

$$R = \frac{v_i^2 \sin 2\theta_i}{g}$$

The maximum value of  $R$  from the above equation is  $R_{max} = v_i^2/g$ . The maximum value of  $\sin 2\theta$  is 1, which occurs when  $2\theta = 90^\circ$ . Therefore,  $R$  is a maximum when  $\theta = 45^\circ$ .

**Ex:** A long jumper leaves the ground at an angle of  $20.0^\circ$  above the horizontal and at a speed of  $11.0 \text{ m/s}$ . (A) How far does he jump in the horizontal direction? (B) What is the maximum height reached?

**Solution**

$$R = \frac{v_i^2 \sin 2\theta_i}{g} = \frac{(11.0 \text{ m/s})^2 \sin 2(20.0^\circ)}{9.80 \text{ m/s}^2} = 7.94 \text{ m}$$

$$h = \frac{v_i^2 \sin^2 \theta_i}{2g} = \frac{(11.0 \text{ m/s})^2 (\sin 20.0^\circ)^2}{2(9.80 \text{ m/s}^2)} = 0.722 \text{ m}$$

**Ex:** A stone is thrown from the top of a building upward at an angle of  $30.0^\circ$  to the horizontal with an initial speed of  $20.0 \text{ m/s}$ . The height from which the stone is

thrown is 45.0 m above the ground. (A) How long does it take the stone to reach the ground? (B) What is the speed of the stone just before it strikes the the ground?

**Solution**

(A)  $v_{xi} = v_i \cos \theta_i = (20 \text{ m/s})\cos 30^\circ = 17.3 \text{ m/s}$

$v_{yi} = v_i \sin \theta_i = (20 \text{ m/s})\sin 30^\circ = 10.0 \text{ m/s}$

$y_f = y_i + v_{yi}t - \frac{1}{2}gt^2$

$-45 \text{ m} = 0 + (10 \text{ m/s})t - \frac{1}{2}(9.8 \text{ m/s}^2)t^2$

$t=4.22 \text{ s}$

(B)  $v_{yf} = v_{yi} - gt$

$v_{yf} = (10 \text{ m/s}) - (9.8 \text{ m/s}^2)(4.22 \text{ s}) = -31.3 \text{ m/s}$

$v_f = \sqrt{v_{xf}^2 + v_{yf}^2} = \sqrt{(17.3 \text{ m/s})^2 + (31.3 \text{ m/s})^2} = 35.8 \text{ m/s}$

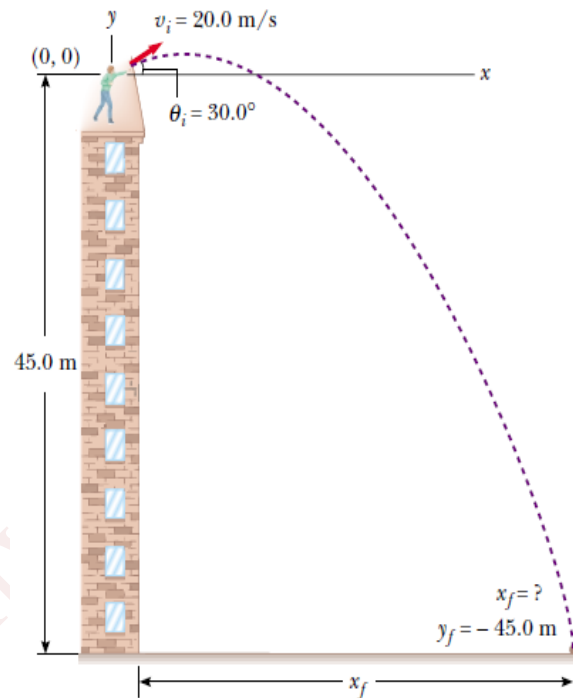

**Ex:** A plane drops a package of supplies to a party of explorers, as shown in figure below. If the plane is traveling horizontally at 40.0 m/s and is 100 m above the ground. A) where does the package strike the ground relative to the point at which it is released? B) what are the horizontal and vertical component of the velocity of the package just before hits the ground. C) Where is the plane when the package hits the ground (assume the plane doesn't change its speed)

Soln.

A)  $x_f = x_i + v_{xi}t \rightarrow x_f = 0 + (40)t \rightarrow x_f = 40t$

$y_f - y_i = v_{yi}t - \frac{1}{2}gt^2 \rightarrow -100 - 0 = 0 - \frac{1}{2}(9.8)t^2$

$t = 4.52 \text{ s} \rightarrow x_f = (40)(4.52) = 181 \text{ m}$

B) The horizontal component of the velocity of the Package remain constant  $\rightarrow v_{xf} = v_{xi} = 40 \text{ m/s}$

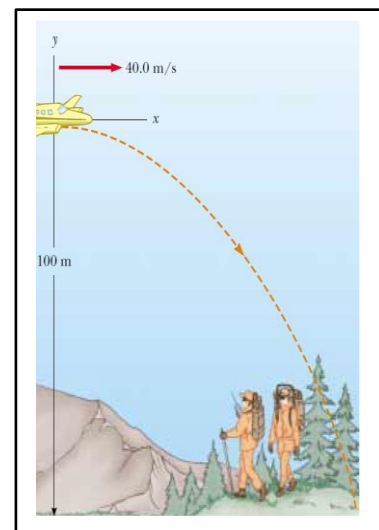

$$v_{yf}^2 = v_{yi}^2 - 2g\Delta y \rightarrow v_{yf}^2 = 0 - 2(9.8 \text{ m/s}^2)(-100 \text{ m}) \rightarrow v_{yf} = \pm 44.3 \text{ m/s}$$

Take  $v_{yf} = -44.3 \text{ m/s}$  because directed downward

C)  $x_f = v_x t \rightarrow x_f = (40)(4.52) = 181 \text{ m}$  (directly over the package)

### 3-4- Uniform Circular Motion

An object moving in a circular path with constant speed, such motion is called uniform circular motion. In uniform circular motion, we have:

- 1) The constant-magnitude velocity vector is always tangent to the path of the object and perpendicular to the radius of the circular path.
- 2) The acceleration vector in uniform circular motion is always perpendicular to the path and always points toward the center of the circle. An acceleration of this nature is called a **centripetal acceleration**, and its magnitude is

$$a_c = \frac{v^2}{r} \dots\dots\dots(3-4-1)$$

where  $r$  is the radius of the circle.

To derive equation (3-4-1), consider the diagram of the position and velocity vectors in figure (3-4-1). The magnitude of the average acceleration is:

$$|\vec{a}_{ave}| = \frac{|\Delta\vec{v}|}{\Delta t} \dots\dots\dots(3-4-2)$$

The two triangles in figure (3-4-1) are similar. This enables us to write a relationship between the lengths of the sides for the two triangles:

$$\frac{|\Delta\vec{v}|}{v} = \frac{|\Delta\vec{r}|}{r}$$

$$|\Delta\vec{v}| = \frac{v|\Delta\vec{r}|}{r} \dots\dots\dots(3-4-3)$$

Where  $v_i = v_f = v$  and  $r_i = r_f = r$

Substitute eq. (3-4-3) into eq. (3-4-2)

$$|\vec{a}_{ave}| = \frac{v}{r} \frac{|\Delta\vec{r}|}{\Delta t}$$

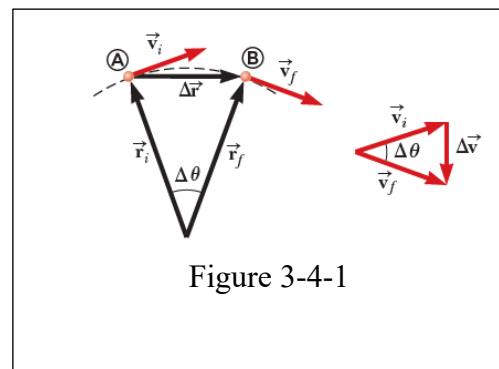

Figure 3-4-1

As **A** and **B** approach each other,  $\Delta t$  approaches zero, and the ratio  $|\Delta\vec{r}|/\Delta t$  approaches the speed  $v$ . In addition, the average acceleration becomes the instantaneous acceleration at point **A**. Hence, in the limit  $\Delta t \rightarrow 0$ , the magnitude of the acceleration is:

$$a_c = \lim_{\Delta t \rightarrow 0} |\vec{a}_{ave}| = \frac{v}{r} \lim_{\Delta t \rightarrow 0} \frac{|\Delta \vec{r}|}{\Delta t} = \frac{v^2}{r}$$

Thus, in uniform circular motion the acceleration is directed inward toward the center of the circle and has magnitude  $v^2/r$ .

In many situations it is convenient to describe the motion of a particle moving with constant speed  $v$  in a circle of radius  $r$  in terms of the period  $T$ , which is defined as the time required for one complete revolution. In the time interval  $T$  the particle moves a distance of  $2\pi r$ , which is equal to the circumference of the particle's circular path. Therefore, it follows that:

$$T = \frac{2\pi r}{v} \dots\dots\dots(3-4-4)$$

**3-5- Tangential and Radial Acceleration**

If a particle moves along a curved path in such a way that both the magnitude and the direction of velocity vector  $\vec{v}$  change in time; we call the motion non-uniform circular motion as shown in figure (3-4-2). So, the particle has an acceleration vector  $\vec{a}$  that can be described by two components vectors:

1- The tangential acceleration  $a_t$  causes the change in the speed of the particle. It is parallel to the instantaneous velocity and perpendicular to the radius. The magnitude of the tangential acceleration is:

$$a_t = \frac{d|\vec{v}|}{dt} \dots\dots\dots(3-4-5)$$

The direction of the tangential component is:

- i) In the same direction of  $\vec{v}$  (if  $\vec{v}$  is increasing).
- ii) In the opposite direction to  $\vec{v}$  (if  $\vec{v}$  is decreasing).

2- The radial (centripetal) acceleration  $a_r$  arises from the changes in direction of the velocity vector  $\vec{v}$  and has an absolute magnitude given by:

$$a_r = a_c = \frac{v^2}{r}$$

The total acceleration vector  $\vec{a}$  can be written as the vector sum of the component vectors:

$$\vec{a} = \vec{a}_t + \vec{a}_r = \frac{d|\vec{v}|}{dt} \hat{\theta} - \frac{v^2}{r} \hat{r} \dots\dots\dots(3-4-6)$$

The negative sign indicates that the direction of the centripetal acceleration is toward the center of the circle representing the radius of curvature, which is opposite the direction of the radial unit vector  $\hat{r}$ , which always points away from the center of the circle.

Because  $\vec{a}_r$  and  $\vec{a}_t$  are perpendicular component vectors of  $\vec{a}$ , it follows that the magnitude of  $\vec{a}$  is:

$$a = \sqrt{a_r^2 + a_t^2} \dots\dots\dots(3-4-7)$$

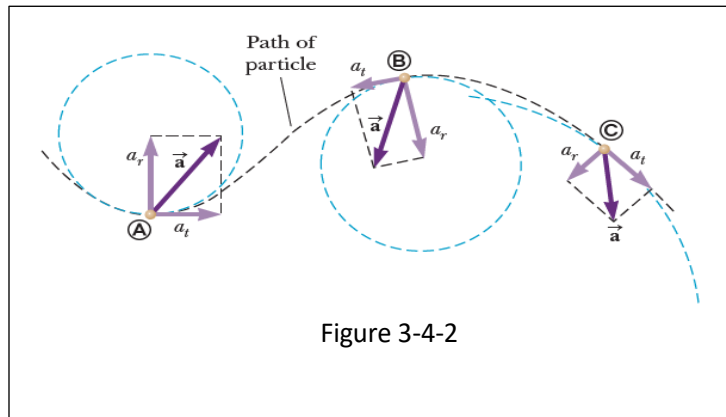

Figure 3-4-2

**Ex:** A train slows down as it rounds a sharp horizontal turn, going from 90.0 km/h to 50.0 km/h in 15.0 s that it takes to round the bend. The radius of the curve is 150 m. Compute the acceleration at the moment the train speed reaches 50.0 km/h. Assume the train continues to slow down at this time at the same rate.

**Solution:**

$$v_i = 90 \frac{km}{h} = 90 \frac{km}{h} \frac{10^3 m}{km} \frac{1 h}{3600 s} = 25 \text{ m/s} \quad v_f = 50 \frac{km}{h} = 50 \frac{km}{h} \frac{10^3 m}{km} \frac{1 h}{3600 s} = 13.9 \text{ m/s}$$

$$a_t = \frac{\Delta v}{\Delta t} = \frac{(13.9 - 25) \text{ m/s}}{15 \text{ s}} = -0.741 \text{ m/s}^2 \text{ (backward)}$$

$$a_r = \frac{v^2}{r} = \frac{(13.9 \text{ m/s})^2}{150 \text{ m}} = 1.29 \text{ m/s}^2 \text{ (inward)}$$

$$a = \sqrt{a_r^2 + a_t^2} = \sqrt{(1.29)^2 + (-0.741)^2} = 1.48 \text{ m/s}^2$$

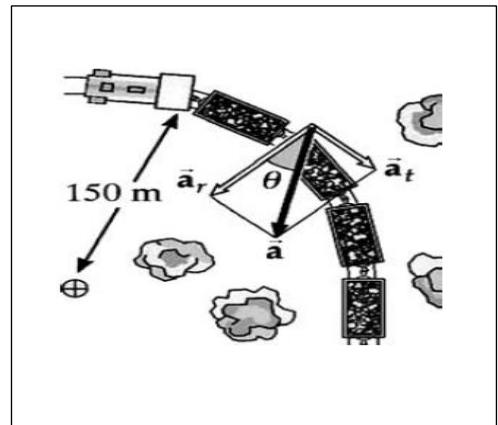

$$\theta = \tan^{-1} \left( \frac{a_t}{a_r} \right) = \tan^{-1} \left( \frac{0.741}{1.29} \right) = 30^\circ$$

**Ex:** Figure below represents the total acceleration of a particle moving clockwise in a circle of radius 2.50 m at a certain instant of time. For that instant, find (a) the radial acceleration of the particle, (b) the speed of the particle, and (c) its tangential acceleration. (d) time of period.

**Solution:**

a) The acceleration has a inward radial component:

$$a_c = a \cos 30^\circ = (15) \cos 30^\circ = 13 \text{ m/s}^2$$

$$b) a_c = \frac{v^2}{r} \rightarrow v = \sqrt{a_c r} = \sqrt{(13)(2.5)} = 5.7 \text{ m/s}$$

c) The tangential component of the acceleration:

$$a_t = a \sin 30^\circ = (15) \sin 30^\circ = 7.5 \text{ m/s}^2$$

$$d) T = \frac{2\pi r}{v} = \frac{2\pi(2.5)}{5.7} = 2.75 \text{ s}$$

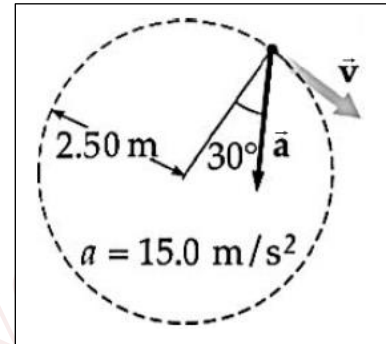

**Ex:** A car is driving on a circle path road with radius of 25 m, at speed of 18 m/s. Calculate the period of the car, frequency of moving car and centripetal acceleration.

**Solution:**

$$v = \frac{2\pi r}{T} \Rightarrow T = \frac{2\pi r}{v} = \frac{2\pi \times 25}{18} = 8.7266 \text{ sec}$$

$$f = \frac{1}{T} = \frac{1}{8.7266} = 0.1146 \text{ Hz} = 1146 \times 10^{-4} \text{ Hz}$$

$$a_r = \frac{v^2}{r} = \frac{(18)^2 \text{ m}^2/\text{s}^2}{25 \text{ m}} = 12.96 \text{ m/s}^2$$