

Chapter Four

The Laws of Motion

4-1 The Concept of Force

A force \vec{F} is defined as an interaction between two bodies or between a body and its environment. A force is a vector quantity, and the SI unit of the magnitude of the force is the newton (N). The net force $\sum \vec{F}$ acting on an object is defined as the vector sum of all forces acting on the object. We sometimes refer to the net force as the total force or the resultant force. If the net force exerted on an object is zero, the acceleration of the object is zero and the object either remains at rest or continues to move with constant velocity. When an object is either at rest or moving with constant velocity (in a straight line with constant speed), we say that the object is in equilibrium.

There are two classes of forces:

- 1) *Contact forces*, when a force involves direct contact between two objects.

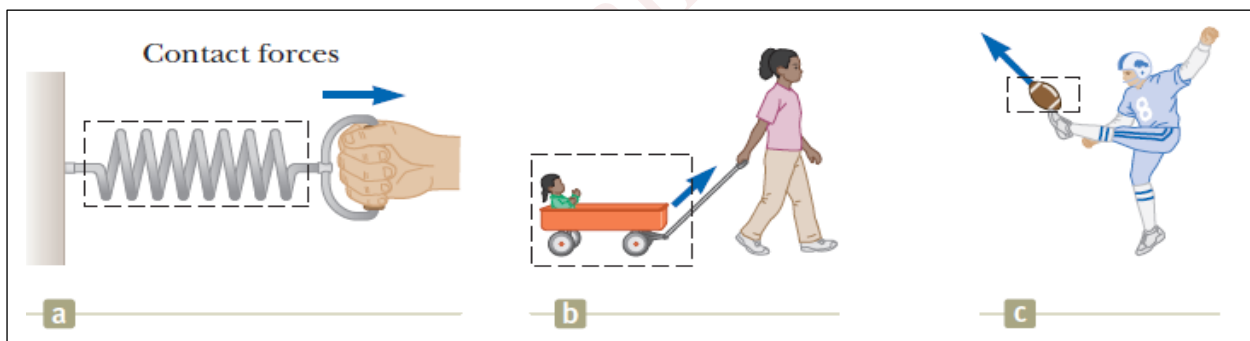

- 2) *Field forces*, they do not involve physical contact between two objects. These forces act through empty space.

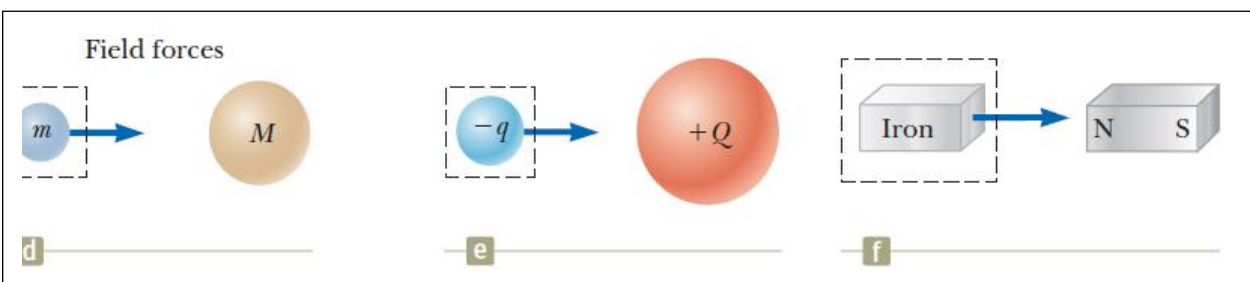

4-2 Newton’s first law

An object at rest stays at rest and an object in motion stays in motion at a constant speed and direction unless acted upon by an external force.

$$\sum \vec{F} = 0 \quad (\text{Object in equilibrium}) \quad \dots\dots\dots(4-2-1)$$

For this to be true, each component of the net force must be zero, so

$$\begin{aligned} \sum F_x &= 0 \\ \sum F_y &= 0 \quad (\text{Object in equilibrium}) \quad \dots\dots\dots(4-2-2) \\ \sum F_z &= 0 \end{aligned}$$

Newton’s first law of motion sometimes called the law of inertia.

The tendency of an object to resist any attempt to change its state (either at rest or in motion) is called inertia.

4-3 Frame of reference

- A reference frame is a space in which we are making observations and measuring physical quantities.
- A reference frame is either at rest or moves with constant velocity is called inertial frame of reference. A reference frame that is accelerating in either linear fashion or rotating around some axis is called non inertial reference frame.
- Any reference frame that moves with constant velocity relative to an inertial frame is itself an inertial frame.
- Newton’s first law is only valid in inertial frame of reference.

4-4 Mass

- The mass is the amount of matter in an object and is an intrinsic characteristic of the body.
- Mass is that property of an object that specifies how much resistance an object exhibits to changes in its velocity.
- The greater the mass of an object, the less that object accelerates under the action of a given applied force.
- Mass is a scalar quantity.

4-5 Newton’s second law

The acceleration of an object is directly proportional to the net force acting on it and inversely proportional to its mass.

$$\sum \vec{F} = m\vec{a} \dots\dots\dots(4-5-1)$$

Equation (4-5-1) is equivalent to three component equations:

$$\sum F_x = ma_x \quad \sum F_y = ma_y \quad \sum F_z = ma_z \dots\dots\dots(4-5-2)$$

4-6 The gravitational force and weight

- The attractive force exerted by the Earth on an object is called the gravitational force and is directed toward the center of the Earth, and is given by: $\vec{F}_g = m\vec{g}$.
- The magnitude of the gravitational force is called the weight of an object $F_g = mg$

4-7 Newton’s third law

If two objects interact, the force \vec{F}_{12} exerted by object 1 on object 2 is equal in magnitude and opposite in direction to the force \vec{F}_{21} exerted by object 2 on object 1:

$$\vec{F}_{12} = -\vec{F}_{21}$$

Ex: A worker applies a constant horizontal force with magnitude 20 N to a box with mass 40 kg resting on a level floor with negligible friction. What is the acceleration of the box?

Solution:

$$\sum F_x = ma_x$$

$$a_x = \frac{\sum F_x}{m} = \frac{20 \text{ N}}{40 \text{ kg}} = 0.5 \text{ m/s}^2$$

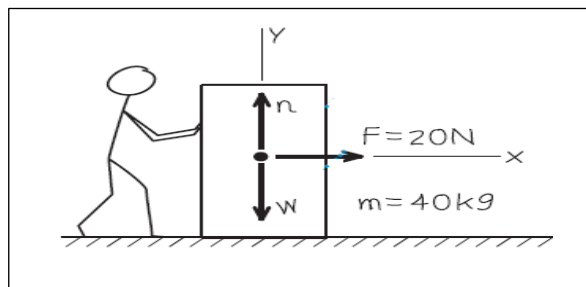

Ex: A hockey puck having a mass of 0.30 kg slides on horizontal, frictionless surface of an ice rink. Two hockey sticks strike the puck simultaneously, exerting the forces on the puck. The force \vec{F}_1 has a magnitude of 5.0 N, and is directed at $\theta = 20^\circ$ below the x-axis and the force \vec{F}_2 has a magnitude of 8.0 N and is directed at $\varphi = 60^\circ$ above the x-axis. Determine both the magnitude and the direction of the puck's acceleration.

Solution:

$$\sum F_x = ma_x \rightarrow a_x = \frac{\sum F_x}{m} \rightarrow a_x = \frac{F_{1x} + F_{2x}}{m}$$

$$a_x = \frac{F_1 \cos(-20^\circ) + F_2 \cos(60^\circ)}{m}$$

$$a_x = \frac{(5 \text{ N}) \cos(-20^\circ) + (8 \text{ N}) \cos(60^\circ)}{0.3 \text{ kg}} = \frac{8.7 \text{ N}}{0.3 \text{ kg}} = 29 \text{ m/s}^2$$

$$\sum F_y = ma_y \rightarrow a_y = \frac{\sum F_y}{m} \rightarrow a_y = \frac{F_{1y} + F_{2y}}{m}$$

$$a_y = \frac{F_1 \sin(-20^\circ) + F_2 \sin(60^\circ)}{m}$$

$$a_y = \frac{(5 \text{ N}) \sin(-20^\circ) + (8 \text{ N}) \sin(60^\circ)}{0.3 \text{ kg}} = \frac{5.2 \text{ N}}{0.3 \text{ kg}} = 17 \text{ m/s}^2$$

$$a = \sqrt{a_x^2 + a_y^2} = \sqrt{(29)^2 + (17)^2} = 34 \text{ m/s}^2$$

$$\theta = \tan^{-1}\left(\frac{a_y}{a_x}\right) = \tan^{-1}\left(\frac{17}{29}\right) = 30^\circ$$

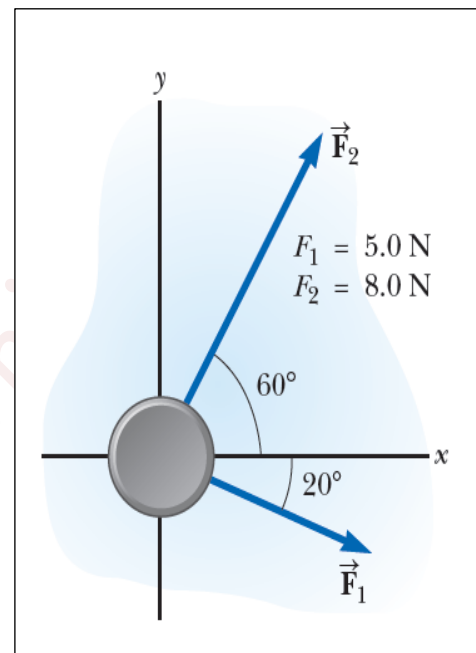

Ex: A traffic light weighing 122 N hangs from a cable tied to two other cables fastened to a support, as in the figure below. The upper cables make angles of 37.0° and 53.0° with the horizontal. These upper cables are not as strong as the vertical cable, and will break if the tension in them exceeds 100 N. Will the traffic light remain hanging in this situation, or will one of the cables break?

Solution:

Apply equilibrium condition for the traffic light in the y-direction

$$\sum F_y = 0 \rightarrow T_3 - F_g = 0 \rightarrow T_3 = F_g = 122 \text{ N}$$

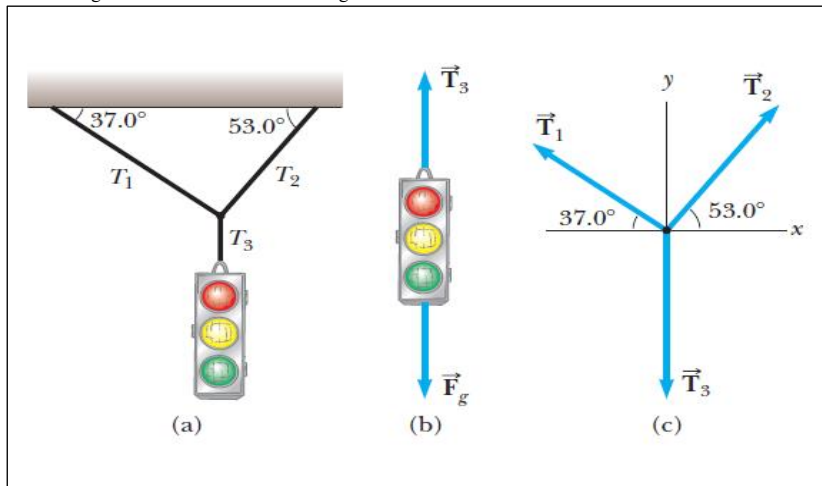

Apply the equilibrium condition to the knot in the x-direction:

$$\sum F_x = 0 \rightarrow -T_1 \cos 37^\circ + T_2 \cos 53^\circ = 0$$

$$T_2 = T_1 \left(\frac{\cos 37^\circ}{\cos 53^\circ} \right) = 1.33 T_1 \dots\dots\dots(1)$$

Apply the equilibrium condition to the knot in the y-direction:

$$\sum F_y = 0 \rightarrow T_1 \sin 37^\circ + T_2 \sin 53^\circ + (-122 \text{ N}) = 0 \dots\dots\dots (2)$$

Substitute equation (1) into (2)

$$T_1 \sin 37^\circ + (1.33 T_1) \sin 53^\circ - 122 \text{ N} = 0 \rightarrow T_1 = 73.4 \text{ N}$$

$$T_2 = 1.33 T_1 \rightarrow T_2 = (1.33)(73.4) = 97.4 \text{ N}$$

Both T_1 and T_2 are less than 100 N, so the cables will not break.

Ex: A car of mass m is on an icy driveway inclined at an angle θ . (a) Find the acceleration of the car, assuming that the driveway is frictionless. (b) Suppose the car is released from rest at the top of the incline, and the distance from the car's front bumper to the bottom of the incline is d . How long does it take the front bumper to reach the bottom, and what is the car's speed as it arrives there?

Solution:

a) Apply Newton's second law in the x-direction:

$$\sum F_x = ma_x \rightarrow mg \sin \theta = ma_x \rightarrow a_x = g \sin \theta$$

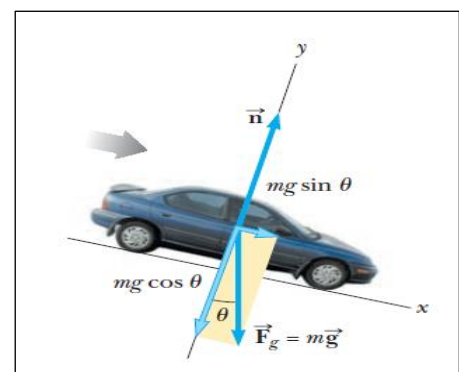

$$\sum F_y = ma_y \rightarrow n - mg \cos \theta = 0 \rightarrow n = mg \cos \theta$$

$$b) \quad x_f - x_i = v_{xi}t + \frac{1}{2}a_x t^2$$

$$v_{xi} = 0, \quad x_i = 0 \quad \text{and} \quad x_f = d$$

$$d = \frac{1}{2}a_x t^2 \rightarrow t = \sqrt{\frac{2d}{a_x}} \rightarrow t = \sqrt{\frac{2d}{g \sin \theta}}$$

$$v_{xf} = v_{xi} + a_x t \rightarrow v_{xf} = 0 + (g \sin \theta) \sqrt{\frac{2d}{g \sin \theta}} = \sqrt{2gd \sin \theta}$$

Ex: Two blocks of masses m_1 and m_2 , with $m_1 > m_2$, are placed in contact with each other on a frictionless, horizontal surface. A constant horizontal force \vec{F} is applied to m_1 as shown below. (a) Find the magnitude of the acceleration of the system. (b) Determine the magnitude of the contact force between the two blocks.

Solution:

a) Apply Newton's Second law to the combination

$$\sum F_x = ma_x \rightarrow F = (m_1 + m_2)a_x \rightarrow a_x = \frac{F}{m_1 + m_2}$$

b) Apply Newton's second law to the m_2

$$\sum F_x = ma_x \rightarrow P_{12} = m_2 a_x \rightarrow P_{12} = \left(\frac{m_2}{m_1 + m_2} \right) F$$

Apply Newton's second law to the m_1

$$\sum F_x = ma_x \rightarrow F - P_{21} = m_1 a_x \rightarrow P_{21} = F - m_1 a_x \rightarrow P_{21} = F - \left(\frac{m_1}{m_1 + m_2} \right) F \rightarrow$$

$$P_{21} = \left(\frac{m_2}{m_1 + m_2} \right) F$$

$$P_{21} = P_{12}$$

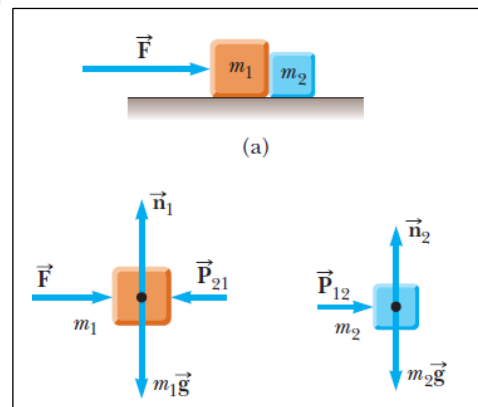

Ex: A person weighs a fish of mass m on a spring scale attached to the ceiling of an elevator, as illustrated in figure below. a) Show that if the elevator accelerates either upward or downward, the spring scale gives a reading that is different from the weight of the fish. b) Evaluate the scale readings for a 40 N fish if the elevator moves with an acceleration $a_y = \pm 2.00 \text{ m/s}^2$.

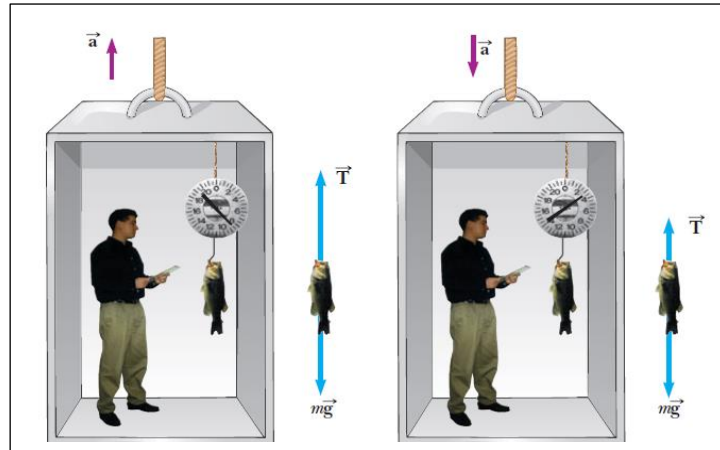

Solution:

a) If the elevator moves with an acceleration \vec{a} relative to an observer standing outside the elevator in an inertial frame.

Newton’s second law applied to the fish gives the net force on the fish:

$$\sum F_y = ma_y \rightarrow T - mg = ma_y \rightarrow T = ma_y + mg \rightarrow T = mg \left(\frac{a_y}{g} + 1 \right) \dots\dots\dots(1)$$

We conclude from equation (1) that:

- The scale reading T is greater than the fish’s weight mg if \vec{a} is upward, so that a_y is positive.
- The reading is less than mg if \vec{a} is downward, so that a_y is negative.

b)

$$\text{If } a_y = 2.00 \text{ m/s}^2 \rightarrow T = (40 \text{ N}) \left(\frac{2 \text{ m/s}^2}{9.8 \text{ m/s}^2} + 1 \right) = 48.2 \text{ N}$$

$$\text{If } a_y = -2.00 \text{ m/s}^2 \rightarrow T = (40 \text{ N}) \left(\frac{-2 \text{ m/s}^2}{9.8 \text{ m/s}^2} + 1 \right) = 31.8 \text{ N}$$

Ex: Determine the magnitude of the acceleration of the two objects and the tension in the lightweight cord, where $m_2 > m_1$, as shown in the figure below.

Solution:

If we define the upward direction as positive for object 1, we must define the downward direction as positive for object 2.

Apply Newton's second law to object 1

$$\sum F_y = ma_y \rightarrow T - m_1g = m_1a_y \quad \dots\dots\dots (1)$$

Apply Newton's second law to object 2

$$\sum F_y = ma_y \rightarrow m_2g - T = m_2a_y \quad \dots\dots\dots (2)$$

Add equation (1) to (2), we get

$$(m_2 - m_1)g = (m_1 + m_2)a_y$$

Solve for the acceleration:

$$a_y = \left(\frac{m_2 - m_1}{m_1 + m_2} \right) g$$

When the last equation is substituted into (1), we obtain

$$T - m_1g = m_1a_y \rightarrow T = m_1(a_y + g) \rightarrow T = m_1 \left(\left(\frac{m_2 - m_1}{m_1 + m_2} \right) g + g \right) \rightarrow T = g \left(\frac{2m_1m_2}{m_1 + m_2} \right)$$

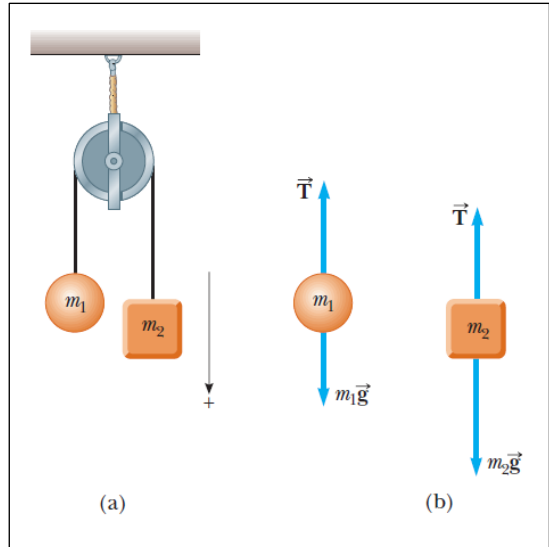

Ex: A ball of mass m_1 and a block of mass m_2 are attached by a lightweight cord that passes over a frictionless pulley of negligible mass, as in figure below. The block lies on a frictionless incline of angle θ . Find the magnitude of the acceleration of the two objects and the tension in the cord.

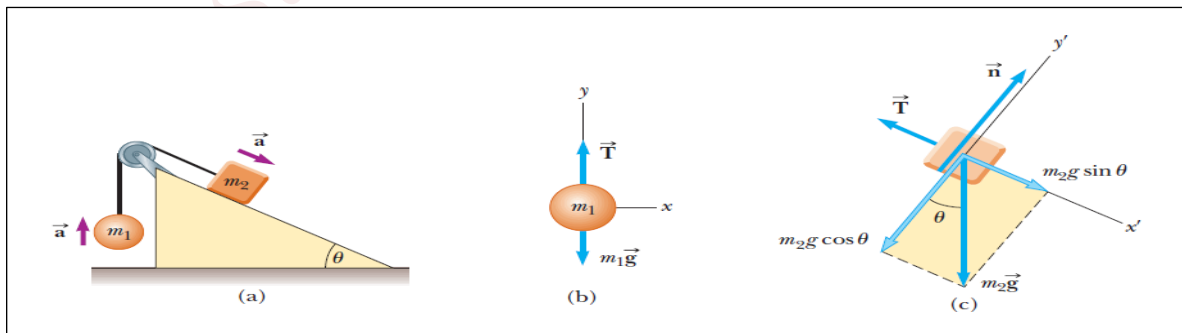

Solution:

Applying Newton's second law in component form to the ball, choosing the upward direction as positive,

$$\sum F_x = 0 \quad \dots\dots\dots (1)$$

$$\sum F_y = ma_y \rightarrow T - m_1g = m_1a_y$$

$$T - m_1g = m_1a \rightarrow T = m_1(g + a) \dots\dots\dots (2)$$

Apply Newton’s second law in component form to the block. It is convenient to choose the positive x’-axis along the incline, we choose the positive direction to be down the incline.

$$\sum F_{x'} = ma_{x'} \rightarrow m_2g \sin \theta - T = m_2a_{x'} \rightarrow m_2g \sin \theta - T = m_2a \dots\dots\dots (3)$$

$$\sum F_{y'} = ma_{y'} \rightarrow n - m_2g \cos \theta = 0 \dots\dots\dots (4)$$

Substitute equation (2) into (3) and solve for a:

$$m_2g \sin \theta - m_1(g + a) = m_2a \rightarrow m_2g \sin \theta - m_1g = (m_1 + m_2)a \rightarrow a = \frac{m_2g \sin \theta - m_1g}{m_1 + m_2}$$

Substitute into equation (2), we get:

$$T = m_1(g + a) \rightarrow T = m_1 \left(g + \frac{m_2g \sin \theta - m_1g}{m_1 + m_2} \right) \rightarrow T = \frac{m_1m_2g(\sin \theta + 1)}{m_1 + m_2}$$

Ex: In the overhead view of figure below, a 2.0 kg cookie tin is accelerated at 3.0 m/s² in the direction shown by \vec{a} , over a frictionless horizontal surface. The acceleration is caused by three horizontal forces, only two of which are shown: \vec{F}_1 of magnitude 10 N and \vec{F}_2 of magnitude 20 N. What is the third force \vec{F}_3 in unit vector notation and in magnitude - angle notation?

Solution:

Apply Newton’s second law: $\sum \vec{F} = m\vec{a}$

$$\vec{F}_1 + \vec{F}_2 + \vec{F}_3 = m\vec{a}$$

$$\vec{F}_3 = m\vec{a} - \vec{F}_1 - \vec{F}_2$$

The x-component:

$$F_{3,x} = ma_x - F_{1,x} - F_{2,x}$$

$$= m(a \cos 50^\circ) - F_1 \cos(-150^\circ) - F_2 \cos 90^\circ$$

$$F_{3,x} = (2.0 \text{ kg})(3.0 \text{ m/s}^2) \cos 50^\circ - (10 \text{ N}) \cos(-150^\circ) - (20 \text{ N}) \cos 90^\circ$$

$$= 12.5 \text{ N}$$

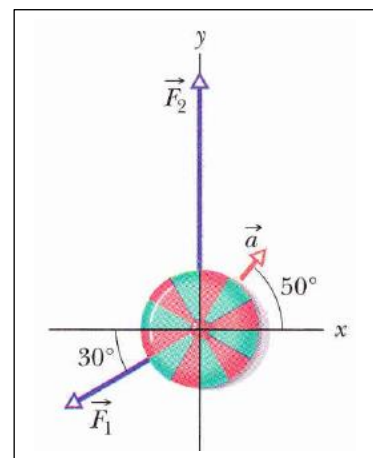

The y-component:

$$\begin{aligned}
 F_{3,y} &= ma_y - F_{1,y} - F_{2,y} \\
 &= m(a \sin 50^\circ) - F_1 \sin(-150^\circ) - F_2 \sin 90^\circ \\
 &= (2.0 \text{ kg})(3.0 \text{ m/s}^2) \sin 50^\circ - (10 \text{ N}) \sin(-150^\circ) \\
 &\quad - (20 \text{ N}) \sin 90^\circ \\
 &= -10.4 \text{ N}.
 \end{aligned}$$

$$\vec{F}_3 = F_{3,x}\hat{i} + F_{3,y}\hat{j} = (12.5 \text{ N})\hat{i} - (10.4 \text{ N})\hat{j}$$

$$F_3 = \sqrt{F_{3,x}^2 + F_{3,y}^2} = 16 \text{ N}$$

$$\theta = \tan^{-1} \frac{F_{3,y}}{F_{3,x}} = -40^\circ.$$

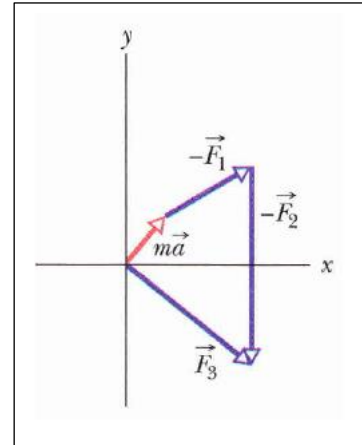

Ex: Besides the gravitational force, a 2.80 kg object is subjected to one other constant force. The object starts from rest and in 1.20 s experiences a displacement of $(4.2\hat{i} - 3.3\hat{j})$ m. Determine the other force.

Solution:

$$\vec{r}_f - \vec{r}_i = \vec{v}_i t + \frac{1}{2} \vec{a} t^2$$

$$4.2\hat{i} - 3.3\hat{j} = 0 + \frac{1}{2} \vec{a} (1.2)^2 \quad \rightarrow \quad \vec{a} = (5.83\hat{i} - 4.58\hat{j}) \text{ m/s}^2$$

$$\sum \vec{F} = m\vec{a} \quad \rightarrow \quad \vec{F}_g + \vec{F} = m\vec{a} \quad \rightarrow$$

$$\vec{F} = m\vec{a} - \vec{F}_g = (2.8)(5.83\hat{i} - 4.58\hat{j}) - (2.8)(-9.8\hat{j}) = (16.3\hat{i} + 14.6\hat{j}) \text{ N}$$

4-8 Forces of Friction

When a force \vec{F} tends to slide a body along a surface, a frictional force from the surface acts on the body. The frictional force is parallel to the surface and directed so as to oppose the sliding. It is due to bonding between the body and the surface. If the body does not slide, the frictional force is a **static frictional force** \vec{f}_s , The magnitude of \vec{f}_s has a maximum value $f_{s,max}$, given by:

$$f_{s,max} = \mu_s n, \quad \dots\dots\dots(4-8-1)$$

where μ_s , is the coefficient of static friction and n is the magnitude of the normal force. If there is sliding, the frictional force is a **kinetic frictional force** \vec{f}_k . The magnitude of \vec{f}_k is given by:

$$f_k = \mu_k n \quad \dots\dots\dots(4-8-2)$$

Where μ_k , is the coefficient of kinetic friction.

Ex: Suppose a block is placed on a rough surface inclined relative to the horizontal, as shown in figure. The incline angle is increased until the block starts to move. Show that by measuring the critical angle θ_c at which this slipping just occurs, we can obtain μ_s .

Solution:

$$\sum F_x = 0 \rightarrow mg \sin \theta - f_s = 0 \rightarrow f_s = mg \sin \theta \quad \dots(1)$$

$$\sum F_y = 0 \rightarrow n - mg \cos \theta = 0 \rightarrow mg = \frac{n}{\cos \theta} \quad \dots\dots(2)$$

Substitute equation (2) into equation (1):

$$f_s = \frac{n}{\cos \theta} \sin \theta = n \tan \theta$$

$$\mu_s = \tan \theta_c$$

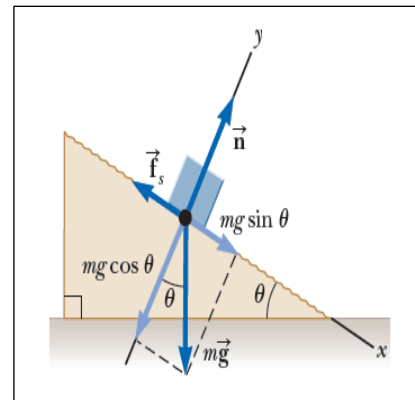

Ex: A hockey puck on a frozen pond is given an initial speed of 20.0 m/s. If the puck always remains on the ice and slides 115 m before coming to rest, determine the coefficient of kinetic friction between the puck and ice.

Solution:

$$\sum F_y = 0 \rightarrow n - mg = 0 \rightarrow n = mg \quad \dots(1)$$

$$\sum F_x = ma_x \rightarrow -f_k = ma_x \rightarrow -n\mu_k = ma_x \dots(2)$$

Substitute equation (1) into equation (2):

$$-mg\mu_k = ma_x \rightarrow a_x = -\mu_k g$$

$$v_{xf}^2 = v_{xi}^2 + 2a_x(x_f - x_i)$$

$$v_{xf} = 0, v_{xi} = 20\text{m/s}, x_i = 0, x_f = 115\text{m},$$

$$0 = v_{xi}^2 - 2\mu_k g x_f \rightarrow \mu_k = \frac{v_{xi}^2}{2g x_f} \rightarrow \mu_k = \frac{(20)^2}{2(9.8)(115)} = 0.177$$

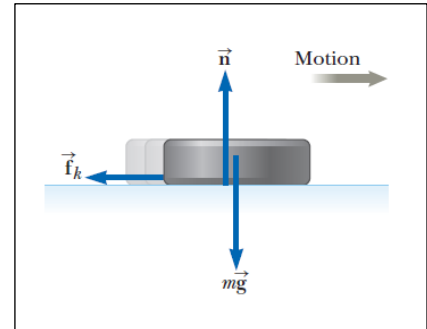

Ex: A block of mass m_2 on a rough, horizontal surface is connected to a ball of mass m_1 by a lightweight cord over a lightweight, frictionless pulley as shown in figure below. A force of magnitude F at an angle θ with the horizontal is applied to the block, and the block slides to the right. The coefficient of kinetic friction between the block and surface is μ_k . Determine the magnitude of the acceleration of the two objects.

Solution:

Apply Newton's second law to the block

$$\sum F_x = ma_x \rightarrow F \cos \theta - f_k - T = m_2 a \dots(1)$$

$$\sum F_y = ma_y \rightarrow n + F \sin \theta - m_2 g = 0$$

$$n = m_2 g - F \sin \theta \dots(2)$$

$$f_k = \mu_k (m_2 g - F \sin \theta) \dots(3)$$

Apply Newton's second law to the ball

$$\sum F_y = ma_y \rightarrow T - m_1 g = m_1 a \rightarrow$$

$$T = m_1 (g + a) \dots(4)$$

Substitute equation (4) and (3) into (1):

$$F \cos \theta - \mu_k (m_2 g - F \sin \theta) - m_1 (g + a) = m_2 a$$

$$a = \frac{F(\cos \theta + \mu_k \sin \theta) - (m_1 + \mu_k m_2)g}{m_1 + m_2}$$

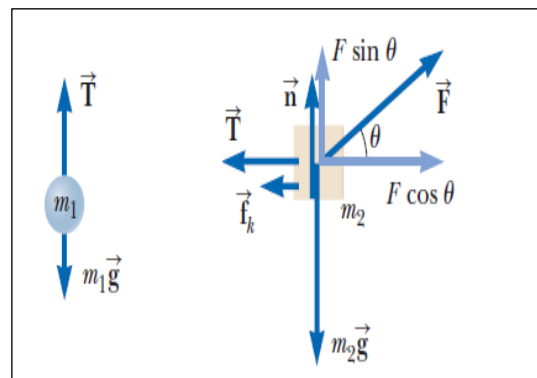
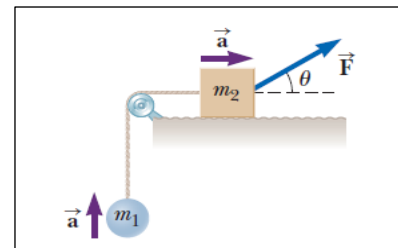

4-9 Centripetal Force

According to Newton's second law, if acceleration occurs, a net force must be causing it. Therefore, when a particle travels in a circular path, a force must be acting inward on the particle. The net force acting on the particle along the radial direction is called centripetal force given by:

$$\sum F_r = ma_r = m \frac{v^2}{r}$$

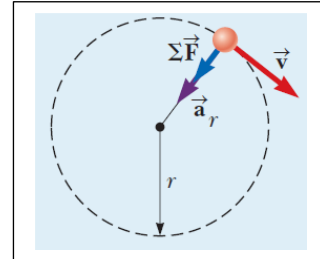

Ex: A puck of mass 0.5 kg is attached to the end of a cord 1.5 m long. The puck moves in a horizontal circle. If the cord can withstand a maximum tension of 50 N, what is the maximum speed at which the puck can move before the cord breaks? Assume the string remains horizontal during the motion.

Solution:

$$\sum F_r = ma_r \quad \rightarrow \quad T = m \frac{v^2}{r} \quad \rightarrow \quad v = \sqrt{\frac{Tr}{m}} \quad \rightarrow \quad v_{\max} = \sqrt{\frac{T_{\max} r}{m}} \quad \rightarrow$$

$$v_{\max} = \sqrt{\frac{(50)(1.5)}{0.50}} = 12.2 \text{ m/s}$$

Ex: Estimate the force a person must exert on a string attached to a 0.15 kg ball to make the ball revolve in a horizontal circle of radius 0.6 m, where the ball makes 30 revolutions every 10 sec.

Solution:

Apply Newton's second law to the radial direction

$$\sum F_r = ma_r = m \frac{v^2}{r} = m \frac{4\pi^2 r}{T^2} = 0.15 \times \left[\frac{4\pi^2 (0.6)}{(10/30)^2} \right] = 40 \text{ N}$$

Ex: (Conical pendulum) A small ball of mass m is suspended from a string of length L . The ball revolves with constant speed in a horizontal circle of radius r as shown in figure below. Find expressions for the speed and the period when the string make an angle θ with the vertical.

Solution:

Let assume T is the tension in the string and t is the period.

$$\sum F_x = T \sin \theta = \frac{mv^2}{r} \rightarrow T \sin \theta = \frac{mv^2}{r} \dots(1)$$

$$\sum F_y = T \cos \theta - mg = 0 \rightarrow T \cos \theta = mg \dots(2)$$

Divided equation (1) on (2)

$$\tan \theta = \frac{v^2}{rg} \rightarrow v = \sqrt{rg \tan \theta}$$

$$r = L \sin \theta \rightarrow v = \sqrt{Lg \sin \theta \tan \theta}$$

$$t = \frac{2\pi r}{v} = \frac{2\pi L \sin \theta}{\sqrt{Lg \sin \theta \tan \theta}} = 2\pi \sqrt{\frac{L}{g} \cos \theta}$$

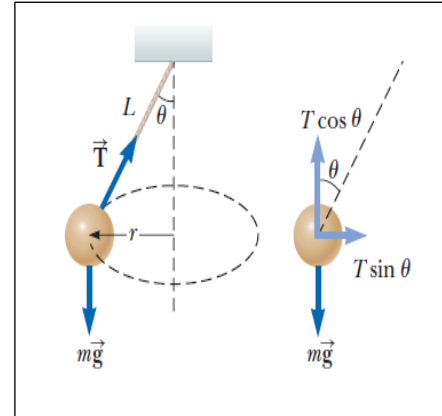

Ex: A sports car is rounding a flat, unbanked curve with radius 35 m. If the coefficient of static friction between tires and road is 0.523 what is the maximum speed at which the driver can take the curve without sliding.

Solution:

$$\sum F_r = ma_r = m \frac{v^2}{r} \rightarrow$$

$$f_{s,max} = \mu_s n = m \frac{v_{max}^2}{r}$$

$$\sum F_y = 0 \rightarrow n - mg = 0 \rightarrow n = mg$$

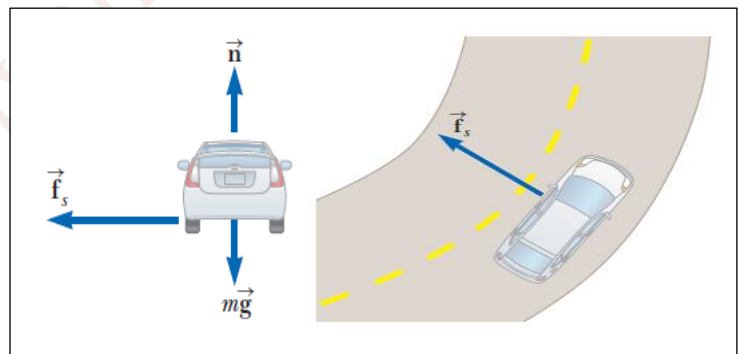

$$v_{max} = \sqrt{\frac{\mu_s nr}{m}} = \sqrt{\frac{\mu_s mgr}{m}} = \sqrt{\mu_s gr}$$

$$v_{max} = \sqrt{(0.523)(9.8)(35)} = 13.4 \text{ m/s}$$

Ex: A 0.15 kg ball on the end of a 1.1 m long cord (negligible mass) is swung in a vertical circle. (a) Determine the minimum speed the ball must have at the top of its arc so that the ball continues moving in a circle. (b) Calculate the tension in the cord at the bottom of the arc, assuming the ball is moving at twice the speed of part (a).

Solution:

(a) Apply Newton’s second law at the top point, for the vertical direction, choosing downward as negative

$$\sum F_y = m \frac{v^2}{r} \rightarrow -T_{\text{top}} - mg = -m \frac{v^2}{r}$$

The minimum speed will occur if $T_{\text{top}} = 0$

$$mg = m \frac{v^2}{r} \rightarrow v_{\text{min}} = \sqrt{gr} = \sqrt{9.8 \times 1.1} = 3.283 \text{ m/s}$$

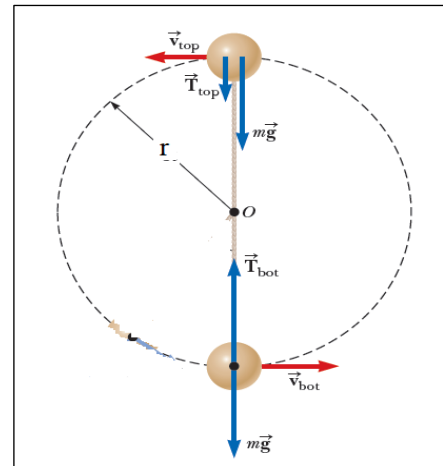

(b) Apply Newton’s second law at the bottom, for the vertical direction, choosing upward as positive

$$\sum F_y = m \frac{v^2}{r} \rightarrow T_{\text{bot}} - mg = m \frac{v^2}{r}$$

$$T_{\text{bot}} = m \left(g + \frac{v^2}{r} \right) = (0.15) \left[(9.8) + \frac{(6.566)^2}{1.10} \right] = 7.35 \text{ N}$$

Ex: A mass, m , on a frictionless table is attached to a hanging mass, M , by a cord through a hole in the table. Find the speed with which m must move in order for M to stay at rest.

Solution:

Apply Newton’s second law to the mass m in the radial direction

$$\sum F_r = T = \frac{mv^2}{r} \dots\dots(1)$$

Apply Newton’s second law to the mass M in the vertical direction,

$$\sum F_y = T - Mg = 0 \rightarrow T = Mg \dots\dots(2)$$

Equate equation (1) and (2): $v = \sqrt{\frac{Mgr}{m}}$

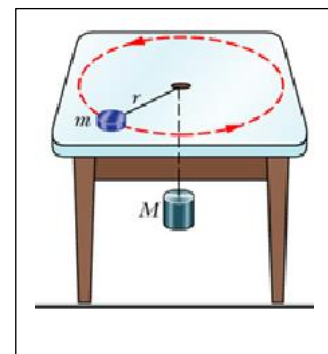

Ex: A car initially traveling eastward turns north by traveling in a circular path at uniform speed as shown in figure below. The length of the arc ABC is 235 m, and the car completes the turn in 36 s. (a) Determine the car’s average speed. (b) What is the acceleration when the car is at B located at an angle of 35° ? Express your

answer in terms of the unit vectors \hat{i} and \hat{j} , and (c) its average acceleration during the 36 s interval.

Solution:

a)

$$v = \frac{235}{36} = 6.5 \text{ m/s}$$

b)

$$\frac{1}{4}(2\pi r) = 235 \text{ m} \quad \rightarrow \quad r = 150 \text{ m}$$

$$a_r = \frac{v^2}{r} = \frac{(6.5)^2}{150} = 0.28 \text{ m/s}^2$$

$$\bar{a} = (-0.28\cos(35)\hat{i} + 0.28\sin(35)\hat{j})\text{m/s}^2 = (-0.23\hat{i} + 0.16\hat{j})\text{m/s}^2$$

c)

$$\bar{a}_{av} = \frac{\bar{v}_f - \bar{v}_i}{t} = \frac{6.5\hat{j} - 6.5\hat{i}}{36} = (-0.18\hat{i} + 0.18\hat{j})\text{m/s}^2$$

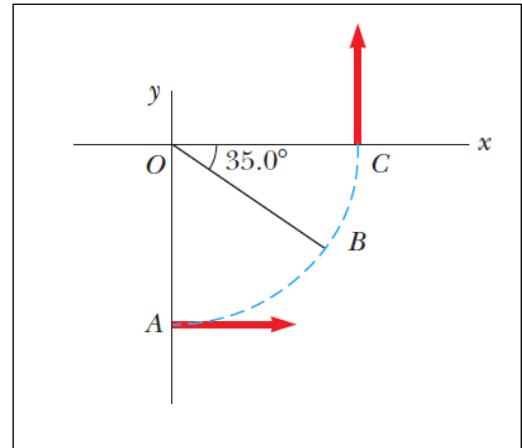

Ex: A 4 kg object is attached to a vertical rod by two strings as shown in figure below. The object rotates in a horizontal circle at constant speed 6 m/s. Find the tension in (a) the upper string and (b) the lower string.

Solution:

$$\sin \theta = \frac{1.5}{2} = 0.75 \quad \rightarrow \quad \theta = 48.6^\circ$$

$$r = 2 \times \cos 48.6 = 1.32 \text{ m}$$

Apply Newton's second law in the radial direction

$$\sum F_r = \frac{mv^2}{r} \quad \rightarrow \quad T_a \cos(48.6) + T_b \cos(48.6) = \left(\frac{4 \times 6^2}{1.32} \right)$$

$$T_a + T_b = \frac{39.2}{\cos(48.6)} = 165 \text{ N} \quad \dots\dots\dots(1)$$

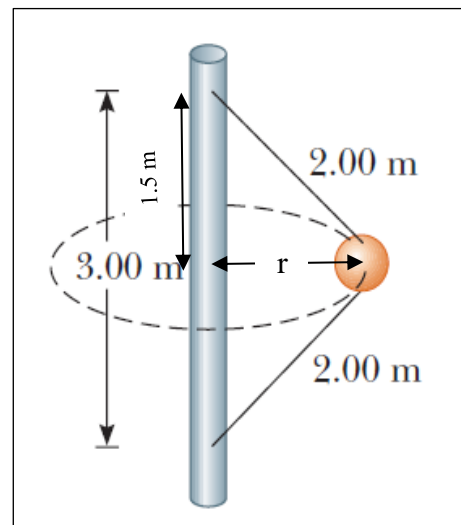

Apply Newton's second law in the vertical direction

$$\sum F_y = 0 \rightarrow T_a \sin(48.6) - T_b \sin(48.6) - mg = 0$$

$$T_a - T_b = \frac{mg}{\sin(48.6)} = \frac{4 \times 9.8}{\sin(48.6)} = 52.3 \text{ N} \quad \dots\dots\dots(2)$$

Combine equation (1) and (2):

$$T_a + T_b + T_a - T_b = 165 + 52.3$$

$$T_a = \frac{217}{2} = 108 \text{ N}$$

$$T_b = 165 - T_a = 165 - 108 = 57 \text{ N}$$

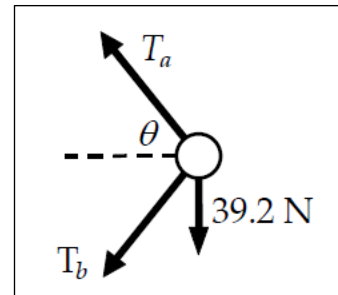

Mustansiriyah University