

Logic design

Prepared by

Dr. Baidaa A. Atya

First stage

(Lecture 11)

2026 - 2025

Chapter three

-A combinational circuit-

5- Multiplexer

A multiplexer is a combinational circuit that has 2^n input lines and a single output line. Simply, the multiplexer is a multi-input and single-output combinational circuit. The binary information is received from the input lines and directed to the output line. On the basis of the values of the selection lines, one of these data inputs will be connected to the output.

Unlike encoder and decoder, there are n selection lines and 2^n input lines. So, there is a total of 2^N possible combinations of inputs. A multiplexer is also treated as **Mux**.

There are various types of the multiplexer which are as follows:

2x1 Multiplexer:

In 2×1 multiplexer, there are only two inputs, i.e., A_0 and A_1 , 1 selection line, i.e., S_0 and single outputs, i.e., Y . On the basis of the combination of inputs which are present at the selection line S^0 , one of these 2 inputs will be connected to the output. The block diagram and the truth table of the 2×1 multiplexer are given below.

Block Diagram:

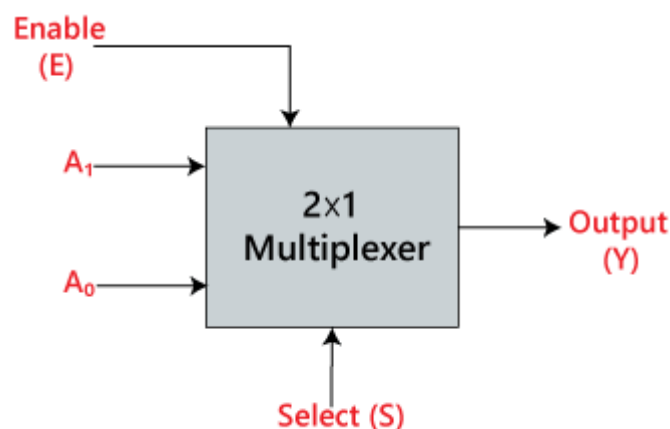

Truth Table:

INPUTS	Output
S_0	Y
0	A_0
1	A_1

The logical expression of the term Y is as follows:

$$Y = S_0' \cdot A_0 + S_0 \cdot A_1$$

Logical circuit of the above expression is given below:

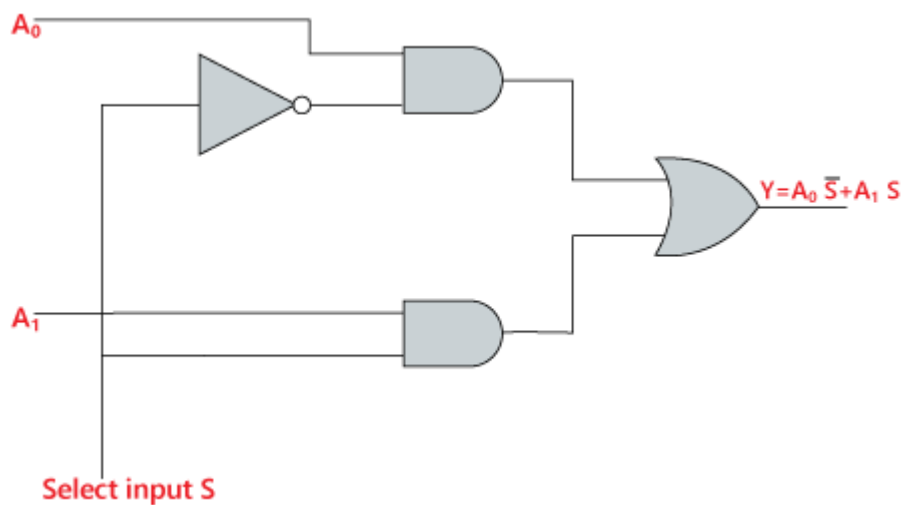

4×1 Multiplexer:

In the 4×1 multiplexer, there is a total of four inputs, i.e., A_0 , A_1 , A_2 , and A_3 , 2 selection lines, i.e., S_0 and S_1 and single output, i.e., Y. On the basis of the combination of inputs that are present at the selection lines S_0 and S_1 , one of these 4 inputs are connected to the output. The block diagram and the truth table of the 4×1 multiplexer are given below.

Block Diagram:

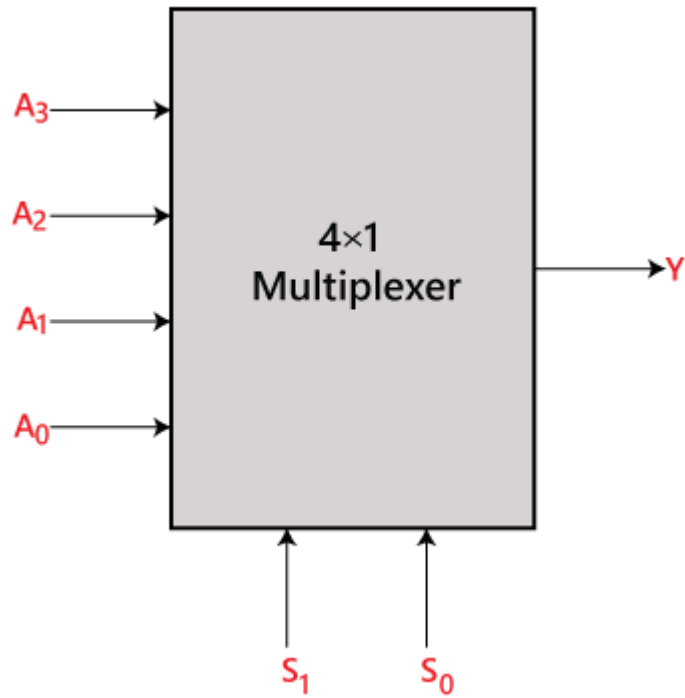

Truth Table:

INPUTS		Output
S_1	S_0	Y
0	0	A_0
0	1	A_1
1	0	A_2
1	1	A_3

The logical expression of the term Y is as follows:

$$Y = S_1' S_0' A_0 + S_1' S_0 A_1 + S_1 S_0' A_2 + S_1 S_0 A_3$$

Logical circuit of the above expression is given below:

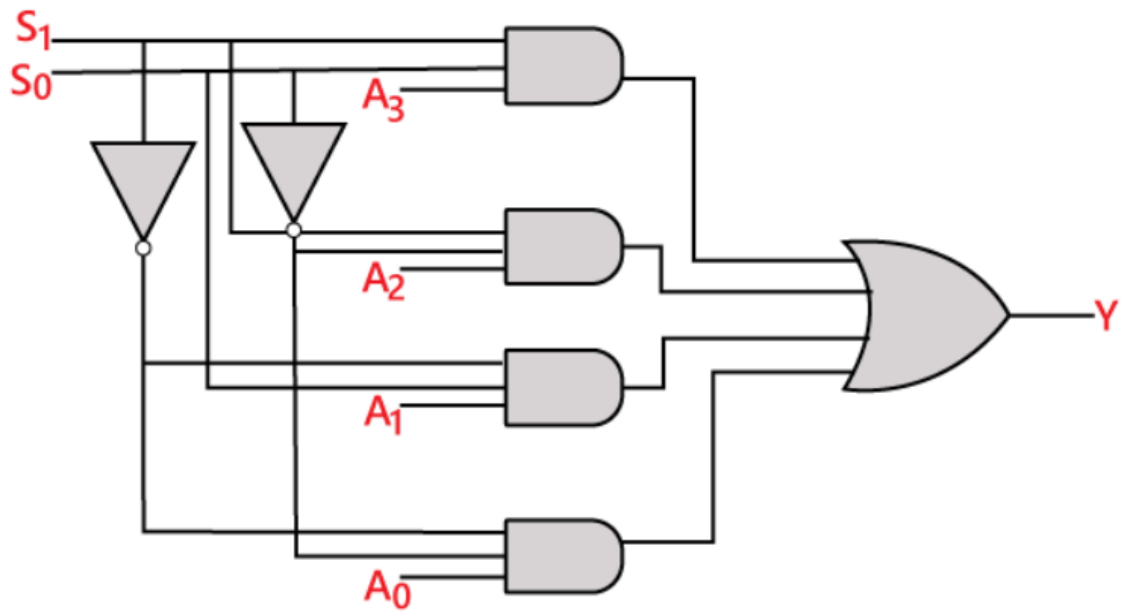

6- Decoder

Decoder is a combinational circuit that has 'n' input lines and maximum of 2^n output lines. One of these outputs will be active High based on the combination of inputs present, when the decoder is enabled. That means decoder detects a particular code. The outputs of the decoder are nothing but the **min terms** of 'n' input variables , when it is enabled.

2 to 4 Decoder

Let 2 to 4 Decoder has two inputs A_1 & A_0 and four outputs Y_3 , Y_2 , Y_1 & Y_0 . The **block diagram** of 2 to 4 decoder is shown in the following figure.

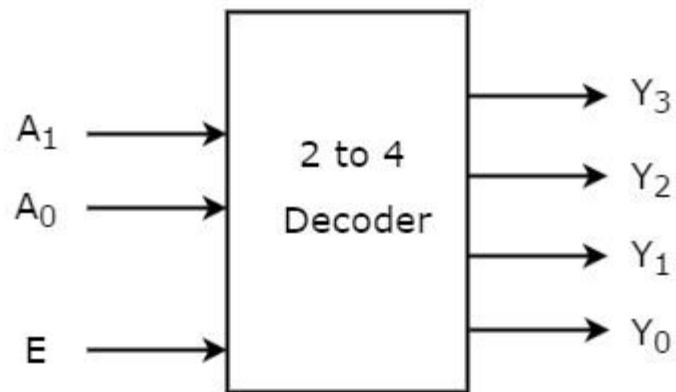

One of these four outputs will be '1' for each combination of inputs when enable, E is '1'. The **Truth table** of 2 to 4 decoder is shown below.

Enable		Inputs		Outputs		
E	A_1	A_0	Y_3	Y_2	Y_1	Y_0
0	x	x	0	0	0	0
1	0	0	0	0	0	1
1	0	1	0	0	1	0
1	1	0	0	1	0	0
1	1	1	1	0	0	0

From Truth table, we can write the **Boolean functions** for each output as

Each output is having one product term. So, there are four product terms in total. We can implement these four product terms by using four AND gates having three inputs each & two inverters. The **circuit diagram** of 2 to 4 decoder is shown in the following figure.

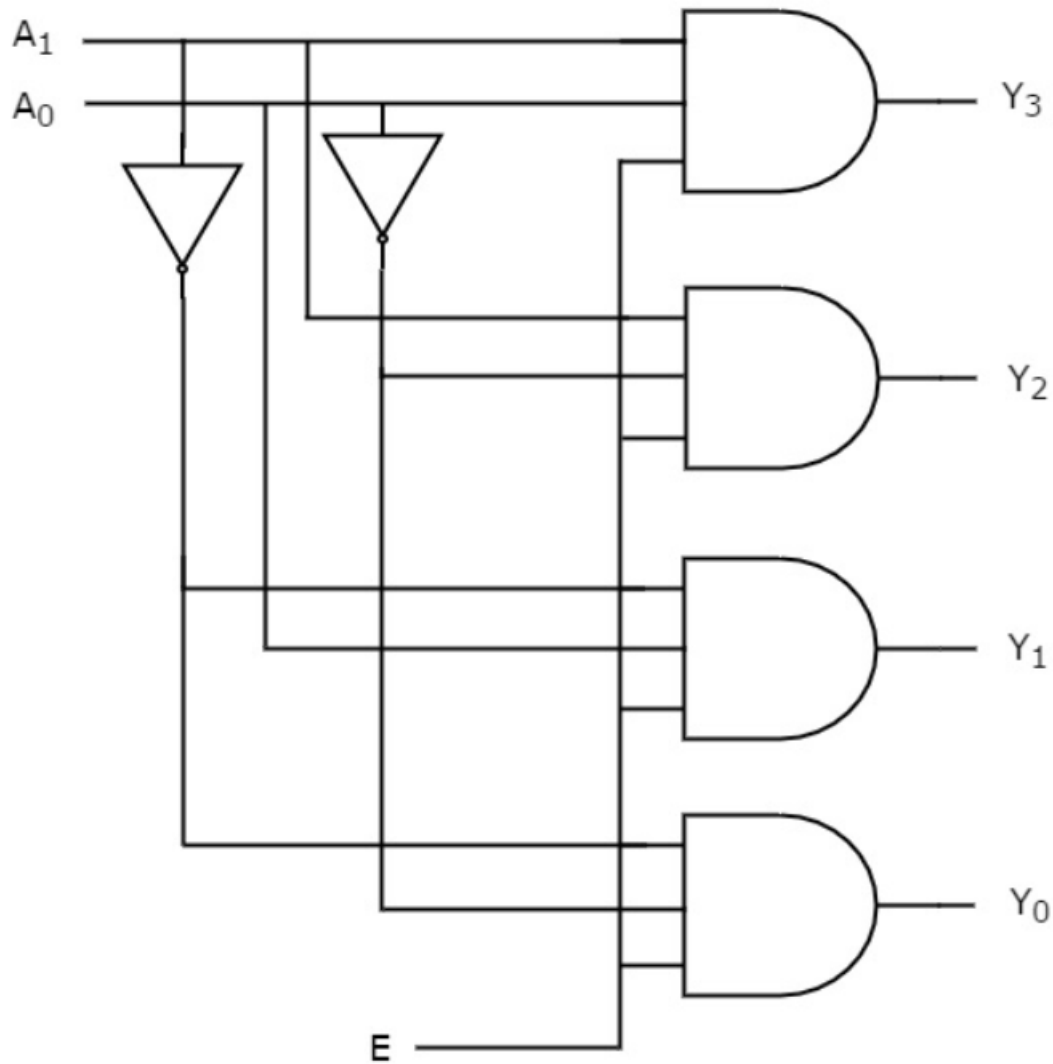

Therefore, the outputs of 2 to 4 decoder are nothing but the min terms of two input variables A_1 & A_0 , when enable, E is equal to one. If enable, E is zero, then all the outputs of decoder will be equal to zero.

Similarly, 3 to 8 decoder produces eight min terms of three input variables A_2 , A_1 & A_0 and 4 to 16 decoder produces sixteen min terms of four input variables A_3 , A_2 , A_1 & A_0 .

7- Encoder

An Encoder is a combinational circuit that performs the reverse operation of Decoder. It has maximum of 2^n input lines and 'n' output lines. It will produce a binary code equivalent to the input, which is active High. Therefore, the encoder encodes 2^n input lines with 'n' bits. It is optional to represent the enable signal in encoders.

4 to 2 Encoder

Let 4 to 2 Encoder has four inputs Y_3, Y_2, Y_1 & Y_0 and two outputs A_1 & A_0 . The block diagram of 4 to 2 Encoder is shown in the following figure.

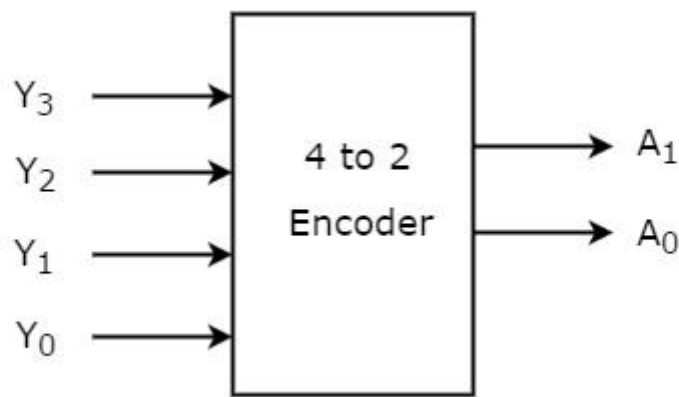

At any time, only one of these 4 inputs can be '1' in order to get the respective binary code at the output. The **Truth table** of 4 to 2 encoder is shown below.

Inputs				Outputs	
Y_3	Y_2	Y_1	Y_0	A_1	A_0
0	0	0	1	0	0
0	0	1	0	0	1
0	1	0	0	1	0
1	0	0	0	1	1

From Truth table, we can write the **Boolean functions** for each output as

$$A_1 = Y_3 + Y_2$$

$$A_0 = Y_3 + Y_1$$

We can implement the above two Boolean functions by using two input OR gates. The **circuit diagram** of 4 to 2 encoder is shown in the following figure.

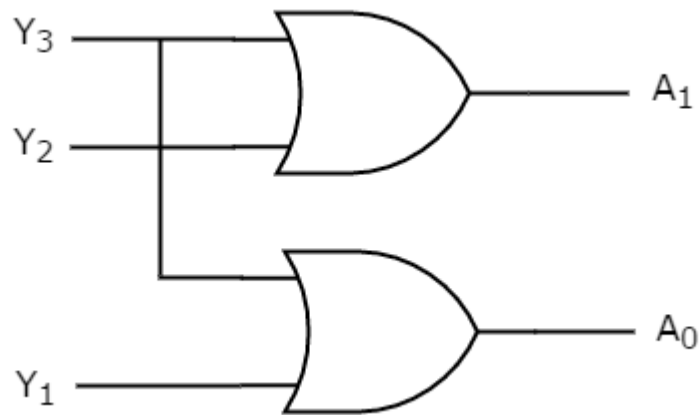

The above circuit diagram contains two OR gates. These OR gates encode the four inputs with two bits.